

MySQL HA/Scalability Guide

MySQL HA/Scalability Guide

Abstract

This is the MySQL HA/Scalability Guide extract from the MySQL Reference Manual.

Document generated on: 2011-01-25 (revision: 24880)

Copyright © 1997, 2011, Oracle and/or its affiliates. All rights reserved.

This software and related documentation are provided under a license agreement containing restrictions on use and disclosure and are protected by intellectual property laws. Except as expressly permitted in your license agreement or allowed by law, you may not use, copy, reproduce, translate, broadcast, modify, license, transmit, distribute, exhibit, perform, publish, or display any part, in any form, or by any means. Reverse engineering, disassembly, or decompilation of this software, unless required by law for interoperability, is prohibited.

The information contained herein is subject to change without notice and is not warranted to be error-free. If you find any errors, please report them to us in writing.

If this software or related documentation is delivered to the U.S. Government or anyone licensing it on behalf of the U.S. Government, the following notice is applicable:

U.S. GOVERNMENT RIGHTS Programs, software, databases, and related documentation and technical data delivered to U.S. Government customers are "commercial computer software" or "commercial technical data" pursuant to the applicable Federal Acquisition Regulation and agency-specific supplemental regulations. As such, the use, duplication, disclosure, modification, and adaptation shall be subject to the restrictions and license terms set forth in the applicable Government contract, and, to the extent applicable by the terms of the Government contract, the additional rights set forth in FAR 52.227-19, Commercial Computer Software License (December 2007). Oracle USA, Inc., 500 Oracle Parkway, Redwood City, CA 94065.

This software is developed for general use in a variety of information management applications. It is not developed or intended for use in any inherently dangerous applications, including applications which may create a risk of personal injury. If you use this software in dangerous applications, then you shall be responsible to take all appropriate fail-safe, backup, redundancy, and other measures to ensure the safe use of this software. Oracle Corporation and its affiliates disclaim any liability for any damages caused by use of this software in dangerous applications.

Oracle is a registered trademark of Oracle Corporation and/or its affiliates. MySQL is a trademark of Oracle Corporation and/or its affiliates, and shall not be used without Oracle's express written authorization. Other names may be trademarks of their respective owners.

This software and documentation may provide access to or information on content, products, and services from third parties. Oracle Corporation and its affiliates are not responsible for and expressly disclaim all warranties of any kind with respect to third-party content, products, and services. Oracle Corporation and its affiliates will not be responsible for any loss, costs, or damages incurred due to your access to or use of third-party content, products, or services.

This document in any form, software or printed matter, contains proprietary information that is the exclusive property of Oracle. Your access to and use of this material is subject to the terms and conditions of your Oracle Software License and Service Agreement, which has been executed and with which you agree to comply. This document and information contained herein may not be disclosed, copied, reproduced, or distributed to anyone outside Oracle without prior written consent of Oracle or as specifically provided below. This document is not part of your license agreement nor can it be incorporated into any contractual agreement with Oracle or its subsidiaries or affiliates.

This documentation is NOT distributed under a GPL license. Use of this documentation is subject to the following terms:

You may create a printed copy of this documentation solely for your own personal use. Conversion to other formats is allowed as long as the actual content is not altered or edited in any way. You shall not publish or distribute this documentation in any form or on any media, except if you distribute the documentation in a manner similar to how Oracle disseminates it (that is, electronically for download on a Web site with the software) or on a CD-ROM or similar medium, provided however that the documentation is disseminated together with the software on the same medium. Any other use, such as any dissemination of printed copies or use of this documentation, in whole or in part, in another publication, requires the prior written consent from an authorized representative of Oracle. Oracle and/or its affiliates reserve any and all rights to this documentation not expressly granted above.

For more information on the terms of this license, for details on how the MySQL documentation is built and produced, or if you are interested in doing a translation, please visit [MySQL Contact & Questions](#).

For additional licensing information, including licenses for third-party libraries used by MySQL products, see [Preface and Notes](#).

If you want help with using MySQL, please visit either the [MySQL Forums](#) or [MySQL Mailing Lists](#) where you can discuss your issues with other MySQL users.

For additional documentation on MySQL products, including translations of the documentation into other languages, and downloadable versions in variety of formats, including HTML and PDF formats, see the [MySQL Documentation Library](#).

Chapter 1. High Availability and Scalability

When using MySQL you may need to ensure the availability or scalability of your MySQL installation. Availability refers to the ability to cope with, and if necessary recover from, failures on the host, including failures of MySQL, the operating system, or the hardware. Scalability refers to the ability to spread the load of your application queries across multiple MySQL servers. As your application and usage increases, you may need to spread the queries for the application across multiple servers to improve response times.

There are a number of solutions available for solving issues of availability and scalability. The two primary solutions supported by MySQL are MySQL Replication and MySQL Cluster. Further options are available using third-party solutions such as DRBD (Distributed Replicated Block Device) and Heartbeat, and more complex scenarios can be solved through a combination of these technologies. These tools work in different ways:

- *MySQL Replication* enables statements and data from one MySQL server instance to be replicated to another MySQL server instance. Without using more complex setups, data can only be replicated from a single master server to any number of slaves. The replication is asynchronous, so the synchronization does not take place in real time, and there is no guarantee that data from the master has been replicated to the slaves.
 - **Advantages**
 - MySQL Replication is available on all platforms supported by MySQL, and since it isn't operating system-specific it can operate across different platforms.
 - Replication is asynchronous and can be stopped and restarted at any time, making it suitable for replicating over slower links, partial links and even across geographical boundaries.
 - Data can be replicated from one master to any number of slaves, making replication suitable in environments with heavy reads, but light writes (for example, many web applications), by spreading the load across multiple slaves.
 - **Disadvantages**
 - Data can only be written to the master. In advanced configurations, though, you can set up a multiple-master configuration where the data is replicated around a ring configuration.
 - There is no guarantee that data on master and slaves is consistent at a given point in time. Because replication is asynchronous, there may be a small delay between data being written to the master and it being available on the slaves. This can cause problems in applications where a write to the master must be available for a read on the slaves (for example a web application).
 - **Recommended uses**
 - Scale-out solutions that require a large number of reads but fewer writes (for example, web serving).
 - Logging/data analysis of live data. By replicating live data to a slave you can perform queries on the slave without affecting the operation of the master.
 - Online backup (availability), where you need an active copy of the data available. You need to combine this with other tools, such as custom scripts or Heartbeat. However, because of the asynchronous architecture, the data may be incomplete.
 - Offline backup. You can use replication to keep a copy of the data. By replicating the data to a slave, you take the slave down and get a reliable snapshot of the data (without MySQL running), then restart MySQL and replication to catch up. The master (and any other slaves) can be kept running during this period.

For information on setting up and configuring replication, see [Replication](#).

- *MySQL Cluster* is a synchronous solution that enables multiple MySQL instances to share database information. Unlike replication, data in a cluster can be read from or written to any node within the cluster, and information is distributed to the other nodes.
 - **Advantages**
 - Offers multiple read and write nodes for data storage.
 - Provides automatic failover between nodes. Only transaction information for the active node being used is lost in the event of a failure.
 - Data on nodes is instantaneously distributed to the other data nodes.

- **Disadvantages**

- Available on a limited range of platforms.
- Nodes within a cluster should be connected through a LAN; geographically separate nodes are not supported. However, you can replicate from one cluster to another using MySQL Replication, although the replication in this case is still asynchronous.

- **Recommended uses**

- Applications that need very high availability, such as telecoms and banking.
- Applications that require an equal or higher number of writes compared to reads.

For information on MySQL Cluster, see [MySQL Cluster](#).

- *DRBD (Distributed Replicated Block Device)* is a solution from Linbit supported only on Linux. DRBD creates a virtual block device (which is associated with an underlying physical block device) that can be replicated from the primary server to a secondary server. You create a file system on the virtual block device, and this information is then replicated, at the block level, to the secondary server.

Because the block device, not the data you are storing on it, is being replicated the validity of the information is more reliable than with data-only replication solutions. DRBD can also ensure data integrity by only returning from a write operation on the primary server when the data has been written to the underlying physical block device on both the primary and secondary servers.

- **Advantages**

- Provides high availability and data integrity across two servers in the event of hardware or system failure.
- Can ensure data integrity by enforcing write consistency on the primary and secondary nodes.

- **Disadvantages**

- Only provides a method for duplicating data across the nodes. Secondary nodes cannot use the DRBD device while data is being replicated, and so the MySQL on the secondary node cannot be simultaneously active.
- Can not be used to scale performance, since you can not redirect reads to the secondary node.

- **Recommended uses**

- High availability situations where concurrent access to the data is not required, but instant access to the active data in the event of a system or hardware failure is required.

For information on configuring DRBD and configuring MySQL for use with a DRBD device, see [Chapter 2, Using MySQL with DRBD](#).

- *memcached* is a simple, yet highly scalable key-based cache that stores data and objects wherever dedicated or spare RAM is available for very quick access by applications. You use *memcached* in combination with your application and MySQL to reduce the number of reads from the database.

When writing your application, you first try to load the data from the *memcached* cache, if the data you are looking for cannot be found, you then load the data from the MySQL database as normal, and populate the cache with the information that you loaded. Because *memcached* can be used to store entire objects that might normally consist of multiple table lookups and aggregations, you can significantly increase the speed of your application because the requirement to load data directly from the database is reduced or even eliminated. Because the cache is entirely in RAM, the response time is very fast, and the information can be distributed among many servers to make the best use of any spare RAM capacity.

- **Advantages**

- Very fast, RAM based, cache.
- Reduces load on the MySQL server, allowing MySQL to concentrate on persistent storage and data writes.
- Highly distributable and scalable, allowing multiple servers to be part of the cache group.
- Highly portable - the *memcached* interface is supported by many languages and systems, including Perl, Python, PHP, Ruby, Java and the MySQL server.

- **Disadvantages**

- Data is not persistent - only use the cache to store information that can be reloaded from a MySQL database.
- Fault tolerance is implied, rather than explicit. If a `memcached` node fails, then your application must be capable of loading the data from MySQL and updating the cache.
- **Recommended uses**
 - High scalability situations where you have a very high number of reads, particularly of complex data objects that can easily be cached in the final, usable, form directly within the cache.

For information on installing, configuring and using `memcached`, including using the many APIs available for communicating with `memcached`, see [Chapter 4, Using MySQL with memcached](#).

- *Heartbeat* is a software solution for Linux. It is not a data replication or synchronization solution, but a solution for monitoring servers and switching active MySQL servers automatically in the event of failure. Heartbeat needs to be combined with MySQL Replication or DRBD to provide automatic failover.

For more information on configuring Heartbeat for use with MySQL and DRBD, see [Chapter 3, Using Linux HA Heartbeat](#).

The information and suitability of the various technologies and different scenarios is summarized in the following table.

Requirements	MySQL Replication	MySQL Replication + Heartbeat	MySQL Heartbeat + DRBD	MySQL Cluster	MySQL + memcached
Availability					
Automated IP failover	No	Yes	Yes	No	No
Automated database failover	No	No	Yes	Yes	No
Typical failover time	User/ script-dependent	Varies	< 30 seconds	< 3 seconds	App dependent
Automatic resynchronization of data	No	No	Yes	Yes	No
Geographic redundancy support	Yes	Yes	Yes, when combined with MySQL Replication	Yes, when combined with MySQL Replication	No
Scalability					
Built-in load balancing	No	No	No	Yes	Yes
Supports Read-intensive applications	Yes	Yes	Yes, when combined with MySQL Replication	Yes	Yes
Supports Write-intensive applications	No	No	Yes	Yes	No
Maximum number of nodes per group	One master, multiple slaves	One master, multiple slaves	One active (primary), one passive (secondary) node	255	Unlimited
Maximum number of slaves	Unlimited (reads only)	Unlimited (reads only)	One (failover only)	Unlimited (reads only)	Unlimited

Chapter 2. Using MySQL with DRBD

The Distributed Replicated Block Device (DRBD) is a Linux Kernel module that constitutes a distributed storage system. You can use DRBD to share block devices between Linux servers and, in turn, share file systems and data.

DRBD implements a block device which can be used for storage and which is replicated from a primary server to one or more secondary servers. The distributed block device is handled by the DRBD service. Writes to the DRBD block device are distributed among the servers. Each DRBD service writes the information from the DRBD block device to a local physical block device (hard disk).

On the primary data writes are written both to the underlying physical block device and distributed to the secondary DRBD services. On the secondary, the writes received through DRBD and written to the local physical block device. On both the primary and the secondary, reads from the DRBD block device are handled by the underlying physical block device. The information is shared between the primary DRBD server and the secondary DRBD server synchronously and at a block level, and this means that DRBD can be used in high-availability solutions where you need failover support.

Figure 2.1. DRBD Architecture Overview

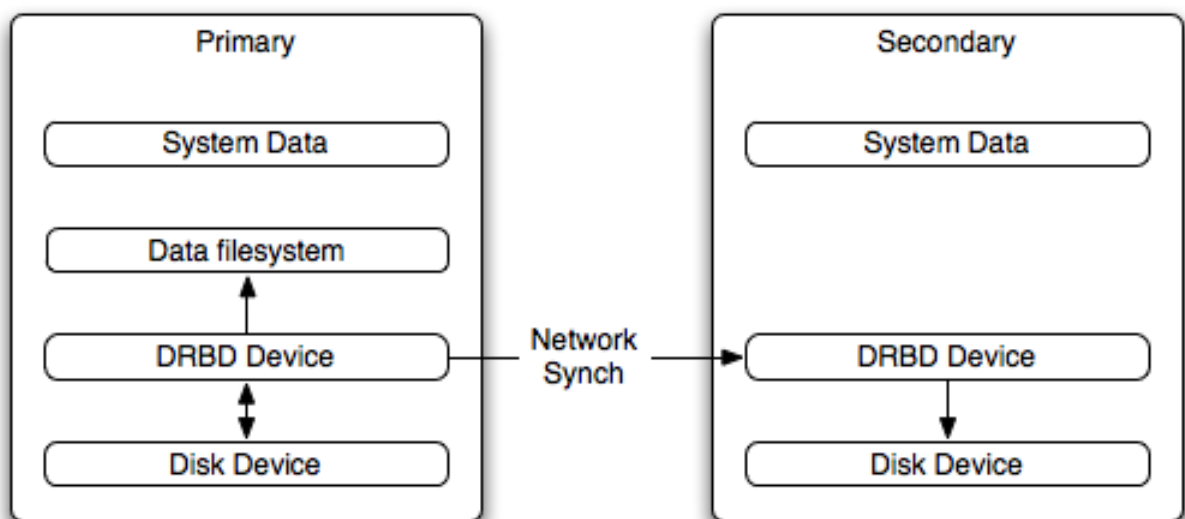

When used with MySQL, DRBD can be used to ensure availability in the event of a failure. MySQL is configured to store information on the DRBD block device, with one server acting as the primary and a second machine available to operate as an immediate replacement in the event of a failure.

For automatic failover support you can combine DRBD with the Linux Heartbeat project, which manages the interfaces on the two servers and automatically configures the secondary (passive) server to replace the primary (active) server in the event of a failure. You can also combine DRBD with MySQL Replication to provide both failover and scalability within your MySQL environment.

For information on how to configure DRBD and MySQL, including Heartbeat support, see [Section 2.1, “Configuring the DRBD Environment”](#).

An FAQ for using DRBD and MySQL is available. See [MySQL 5.0 FAQ: MySQL, DRBD, and Heartbeat](#).

Note

Because DRBD is a Linux Kernel module it is currently not supported on platforms other than Linux.

2.1. Configuring the DRBD Environment

To set up DRBD, MySQL and Heartbeat you need to follow a number of steps that affect the operating system, DRBD and your MySQL installation.

Before starting the installation process, be aware of the following information, terms and requirements on using DRBD:

- DRBD is a solution for enabling high-availability, and therefore you need to ensure that the two machines within your DRBD setup are as identically configured as possible so that the secondary machine can act as a direct replacement for the primary machine in the event of system failure.
- DRBD works through two (or more) servers, each called a *node*
- The node that contains the primary data, has read/write access to the data, and in an HA environment is the currently active node is called the *primary*.
- The server to which the data is replicated is referred as *secondary*.
- A collection of nodes that are sharing information are referred to as a *DRBD cluster*.
- For DRBD to operate you must have a block device on which the information can be stored on *each* DRBD node. The *lower level* block device can be a physical disk partition, a partition from a volume group or RAID device or any other block device.

Typically you use a spare partition on which the physical data is stored. On the primary node, this disk holds the raw data that you want replicated. On the secondary nodes, the disk holds the data replicated to the secondary server by the DRBD service. Ideally, the size of the partition on the two DRBD servers should be identical, but this is not necessary as long as there is enough space to hold the data that you want distributed between the two servers.

- For the distribution of data to work, DRBD is used to create a logical block device that uses the lower level block device for the actual storage of information. To store information on the distributed device, a file system is created on the DRBD logical block device.
- When used with MySQL, once the file system has been created, you move the MySQL data directory (including InnoDB data files and binary logs) to the new file system.
- When you set up the secondary DRBD server, you set up the physical block device and the DRBD logical block device that stores the data. The block device data is then copied from the primary to the secondary server.

The overview for the installation and configuration sequence is as follows:

1. First you need to set up your operating system and environment. This includes setting the correct host name, updating the system and preparing the available packages and software required by DRBD, and configuring a physical block device to be used with the DRBD block device. See [Section 2.1.1, “Setting Up Your Operating System for DRBD”](#).
2. Installing DRBD requires installing or compiling the DRBD source code and then configuring the DRBD service to set up the block devices to be shared. See [Section 2.1.2, “Installing and Configuring DRBD”](#).
3. Once DRBD has been configured, you must alter the configuration and storage location of the MySQL data. See [Section 2.2, “Configuring MySQL for DRBD”](#).

You may optionally want to configure high availability using the Linux Heartbeat service. See [Chapter 3, Using Linux HA Heartbeat](#), for more information.

2.1.1. Setting Up Your Operating System for DRBD

To set your Linux environment for using DRBD there are a number of system configuration steps that you must follow.

- Make sure that the primary and secondary DRBD servers have the correct host name, and that the host names are unique. You can verify this by using the `uname` command:

```
shell> uname -n
drbd-one
```

If the host name is not set correctly, edit the appropriate file (usually `/etc/sysconfig/network`, `/etc/hostname`, or `/etc/conf.d/hostname`) and set the name correctly.

- Each DRBD node must have a unique IP address. Make sure that the IP address information is set correctly within the network configuration and that the host name and IP address has been set correctly within the `/etc/hosts` file.
- Although you can rely on the DNS or NIS system for host resolving, in the event of a major network failure these services may not be available. If possible, add the IP address and host name of each DRBD node into the `/etc/hosts` file for each machine. This ensures that the node information can always be determined even if the DNS/NIS servers are unavailable.
- As a general rule, the faster your network connection the better. Because the block device data is exchanged over the network,

everything that is written to the local disk on the DRBD primary is also written to the network for distribution to the DRBD secondary.

For tips on configuring a faster network connection see [Section 2.3, “Optimizing Performance and Reliability”](#).

- You must have a spare disk or disk partition that you can use as the physical storage location for the DRBD data that is replicated. You do not have to have a complete disk available, a partition on an existing disk is acceptable.

If the disk is unpartitioned, partition the disk using `fdisk`, `cfdisk` or other partitioning solution. Do not create a file system on the new partition.

Remember that you must have a physical disk available for the storage of the replicated information on each DRBD node. Ensure that the physical partition on the DRBD secondary is at least as big as the partitions on the DRBD primary node. Ideally the partitions that are used on each node should have identical sizes, although this is not strictly necessary.

- If possible, upgrade your system to the latest available Linux kernel for your distribution. Once the kernel has been installed, you must reboot to make the kernel active. To use DRBD, you must also install the relevant kernel development and header files that are required for building kernel modules. Platform specification information for this is available later in this section.

Before you compile or install DRBD, you must make sure the following tools and files are in place:

- Kernel header files
- Kernel source files
- GCC Compiler
- `glib 2`
- `flex`

Here are some operating system specific tips for setting up your installation:

- **Tips for Red Hat (including CentOS and Fedora):**

Use `up2date` or `yum` to update and install the latest kernel and kernel header files:

```
root-shell> up2date kernel-smp-devel kernel-smp
```

Reboot. If you are going to build DRBD from source, then update your system with the required development packages:

```
root-shell> up2date glib-devel openssl-devel libgcrypt-devel glib2-devel \  
pkgconfig ncurses-devel rpm-build rpm-devel redhat-rpm-config gcc \  
gcc-c++ bison flex gnutls-devel lm_sensors-devel net-snmp-devel \  
python-devel bzip2-devel libselinux-devel perl-DBI
```

If you are going to use the pre-built DRBD RPMs:

```
root-shell> up2date gnutls lm_sensors net-snmp ncurses libgcrypt glib2 openssl glib
```

- **Tips for Debian, Ubuntu, Kubuntu:**

Use `apt-get` to install the kernel packages

```
root-shell> apt-get install linux-headers linux-image-server
```

If you are going to use the pre-built Debian packages for DRBD, you do not need any additional packages.

If you want to build DRBD from source, use the following command to install the required components:

```
root-shell> apt-get install devscripts flex bison build-essential \  
dpkg-dev kernel-package debconf-utils dpatch debhelper \  
libnet1-dev e2fslibs-dev libglib2.0-dev automake1.9 \  
libgnutls-dev libtool libltdl3 libltdl3-dev
```

- **Tips for Gentoo:**

Gentoo is a source based Linux distribution and therefore many of the source files and components that you need are either already installed or are installed automatically by `emerge`.

To install DRBD 0.8.x, you must unmask the `sys-cluster/drbd` build by adding the following line to `/etc/portage/package.keywords`:

```
sys-cluster/drbd ~x86
sys-cluster/drbd-kernel ~x86
```

To enable the DRBD kernel module, you must rebuild your kernel, although the method depends on the kernel version you are using. Determine your current kernel version using `uname -a`.

- For Linux kernels lower than 2.6.33, enable the userspace kernelspace linker to build and load the DRBD kernel driver. To enable the kernelspace linker, rebuild the kernel with this option. The best way to do this is to use `genkernel` with the `--menuconfig` option to select the option and then rebuild the kernel. For example, at the command line as `root`:

```
root-shell> genkernel --menuconfig all
```

Then through the menu options, select `DEVICE DRIVERS, CONNECTOR - UNIFIED USERSPACE <-> KERNELSPACE LINKER` and finally press 'y' or 'space' to select the `CONNECTOR - UNIFIED USERSPACE <-> KERNELSPACE LINKER` option. After you exit the menu configuration, the kernel is rebuilt and installed. If this is a new kernel, update your bootloader to point to the kernel if the kernel version is different than your current kernel version. Now reboot to enable the new kernel.

- For Linux Kernel 2.6.33 and later, DRBD is included within the kernel sources. To enable the DRBD module you must rebuild your kernel. The best way to do this is to use `genkernel` with the `--menuconfig` option to select the option and then rebuild the kernel. For example, at the command line as `root`:

```
root-shell> genkernel --menuconfig all
```

Then through the menu options, select `DEVICE DRIVERS, BLOCK DEVICES`, and then `DRBD DISTRIBUTED REPLICATED BLOCK DEVICE SUPPORT`. After you exit the menu configuration, the kernel is rebuilt and installed. If this is a new kernel, update your bootloader to point to the kernel if the kernel version is different than your current kernel version. Now reboot to enable the new kernel.

2.1.2. Installing and Configuring DRBD

To install DRBD you can choose either the pre-built binary installation packages or you can use the source packages and build from source. If you want to build from source you must have installed the source and development packages.

If you are installing using a binary distribution then you must ensure that the kernel version number of the binary package matches your currently active kernel. You can use `uname` to find out this information:

```
shell> uname -r
2.6.20-gentoo-r6
```

Once DRBD has been built and installed, you need to edit the `/etc/drbd.conf` file and then run a number of commands to build the block device and set up the replication.

Although the steps below are split into those for the primary node and the secondary node, it should be noted that the configuration files for all nodes should be identical, and many of the same steps have to be repeated on each node to enable the DRBD block device.

Building from source:

To download and install from the source code:

1. Download the source code.
2. Unpack the package:

```
shell> tar zxf drbd-8.3.0.tar.gz
```

3. Change to the extracted directory, and then run `make` to build the DRBD driver:

```
shell> cd drbd-8.3.0
shell> make
```

4. Install the kernel driver and commands:

```
shell> make install
```

Binary Installation:

- **SUSE Linux Enterprise Server (SLES)**

For SUSE, use `yast`:

```
shell> yast -i drbd
```

Alternatively:

```
shell> rug install drbd
```

- **Debian**

Use `apt-get` to install the modules. You do not need to install any other components.

```
shell> apt-get install drbd8-utils drbd8-module
```

- **Debian 3.1 and 4.0**

You must install the `module-assistant` to build the DRBD kernel module, in addition to the DRBD components.

```
shell> apt-get install drbd0.7-utils drbd0.7-module-source \  
  build-essential module-assistant \  
shell> module-assistant auto-install drbd0.7
```

- **CentOS**

DRBD can be installed using `yum`:

```
shell> yum install drbd kmod-drbd
```

- **Ubuntu**

You must enable the universe component for your preferred Ubuntu mirror in `/etc/apt/sources.list`, and then issue these commands:

```
shell> apt-get update \  
shell> apt-get install drbd8-utils drbd8-module-source \  
  build-essential module-assistant \  
shell> module-assistant auto-install drbd8
```

- **Gentoo**

You can now `emerge` DRBD 0.8.x into your Gentoo installation:

```
root-shell> emerge drbd
```

Once `drbd` has been downloaded and installed, you need to decompress and copy the default configuration file from `/usr/share/doc/drbd-8.0.7/drbd.conf.bz2` into `/etc/drbd.conf`.

2.1.3. Setting Up a DRBD Primary Node

To set up a DRBD primary node you need to configure the DRBD service, create the first DRBD block device and then create a file system on the device so that you can store files and data.

The DRBD configuration file `/etc/drbd.conf` defines a number of parameters for your DRBD configuration, including the frequency of updates and block sizes, security information and the definition of the DRBD devices that you want to create.

The key elements to configure are the `on` sections which specify the configuration of each node.

To follow the configuration, the sequence below shows only the changes from the default `drbd.conf` file. Configurations within

the file can be both global or tied to specific resource.

1. Set the synchronization rate between the two nodes. This is the rate at which devices are synchronized in the background after a disk failure, device replacement or during the initial setup. Keep this in check compared to the speed of your network connection. Gigabit Ethernet can support up to 125 MB/second, 100Mbps Ethernet slightly less than a tenth of that (12MBps). If you are using a shared network connection, rather than a dedicated, then gauge accordingly.

To set the synchronization rate, edit the `rate` setting within the `syncer` block:

```
syncer {
    rate 10M;
}
```

You may additionally want to set the `al-extents` parameter. The default for this parameter is 257.

For more detailed information on synchronization, the effects of the synchronization rate and the effects on network performance, see [Section 2.3.2, "Optimizing the Synchronization Rate"](#).

2. Set up some basic authentication. DRBD supports a simple password hash exchange mechanism. This helps to ensure that only those hosts with the same shared secret are able to join the DRBD node group.

```
cram-hmac-alg "sha1";
shared-secret "shared-string";
```

3. Now you must configure the host information. Remember that you must have the node information for the primary and secondary nodes in the `drbd.conf` file on each host. You need to configure the following information for each node:

- `device`: The path of the logical block device that is created by DRBD.
- `disk`: The block device that stores the data.
- `address`: The IP address and port number of the host that holds this DRBD device.
- `meta-disk`: The location where the metadata about the DRBD device is stored. If you set this to `internal`, DRBD uses the physical block device to store the information, by recording the metadata within the last sections of the disk. The exact size depends on the size of the logical block device you have created, but it may involve up to 128MB.

A sample configuration for our primary server might look like this:

```
on drbd-one {
    device /dev/drbd0;
    disk /dev/hdd1;
    address 192.168.0.240:8888;
    meta-disk internal;
}
```

The `on` configuration block should be repeated for the secondary node (and any further) nodes:

```
on drbd-two {
    device /dev/drbd0;
    disk /dev/hdd1;
    address 192.168.0.241:8888;
    meta-disk internal;
}
```

The IP address of each `on` block must match the IP address of the corresponding host. Do not set this value to the IP address of the corresponding primary or secondary in each case.

4. Before starting the primary node, create the metadata for the devices:

```
root-shell> drbdadm create-md all
```

5. You are now ready to start DRBD:

```
root-shell> /etc/init.d/drbd start
```

DRBD should now start and initialize, creating the DRBD devices that you have configured.

6. DRBD creates a standard block device - to make it usable, you must create a file system on the block device just as you would with any standard disk partition. Before you can create the file system, you must mark the new device as the primary device (that is, where the data is written and stored), and initialize the device. Because this is a destructive operation, you must specify the command line option to overwrite the raw data:

```
root-shell> drbdadm -- --overwrite-data-of-peer primary all
```

If you are using a version of DRBD 0.7.x or earlier, then you need to use a different command-line option:

```
root-shell> drbdadm -- --do-what-I-say primary all
```

Now create a file system using your chosen file system type:

```
root-shell> mkfs.ext3 /dev/drbd0
```

7. You can now mount the file system and if necessary copy files to the mount point:

```
root-shell> mkdir /mnt/drbd
root-shell> mount /dev/drbd0 /mnt/drbd
root-shell> echo "DRBD Device" >/mnt/drbd/samplefile
```

Your primary node is now ready to use. Next, configure your secondary node or nodes.

2.1.4. Setting Up a DRBD Secondary Node

The configuration process for setting up a secondary node is the same as for the primary node, except that you do not have to create the file system on the secondary node device, as this information is automatically transferred from the primary node.

To set up a secondary node:

1. Copy the `/etc/drbd.conf` file from your primary node to your secondary node. It should already contain all the information and configuration that you need, since you had to specify the secondary node IP address and other information for the primary node configuration.
2. Create the DRBD metadata on the underlying disk device:

```
root-shell> drbdadm create-md all
```

3. Start DRBD:

```
root-shell> /etc/init.d/drbd start
```

Once DRBD has started, it starts to copy the data from the primary node to the secondary node. Even with an empty file system this takes some time, since DRBD is copying the block information from a block device, not simply copying the file system data.

You can monitor the progress of the copy between the primary and secondary nodes by viewing the output of `/proc/drbd`:

```
root-shell> cat /proc/drbd
version: 8.0.4 (api:86/proto:86)
SVN Revision: 2947 build by root@drbd-one, 2007-07-30 16:43:05
0: cs:SyncSource st:Primary/Secondary ds:UpToDate/Inconsistent C r---
   ns:252284 nr:0 dw:0 dr:257280 al:0 bm:15 lo:0 pe:7 ua:157 ap:0
   [==>.....] sync'ed: 12.3% (1845088/2097152)K
   finish: 0:06:06 speed: 4,972 (4,580) K/sec
   resync: used:1/31 hits:15901 misses:16 starving:0 dirty:0 changed:16
   act_log: used:0/257 hits:0 misses:0 starving:0 dirty:0 changed:0
```

You can monitor the synchronization process by using the `watch` command to run the command at specific intervals:

```
root-shell> watch -n 10 'cat /proc/drbd'
```

2.1.5. Monitoring DRBD Device

Once the primary and secondary machines are configured and synchronized, you can get the status information about your DRBD device by viewing the output from `/proc/drbd`:

```
root-shell> cat /proc/drbd
version: 8.0.4 (api:86/proto:86)
SVN Revision: 2947 build by root@drbd-one, 2007-07-30 16:43:05
0: cs:Connected st:Primary/Secondary ds:UpToDate/UpToDate C r---
   ns:2175704 nr:0 dw:99192 dr:2076641 al:33 bm:128 lo:0 pe:0 ua:0 ap:0
   resync: used:0/31 hits:134841 misses:135 starving:0 dirty:0 changed:135
```

```
act_log: used:0/257 hits:24765 misses:33 starving:0 dirty:0 changed:33
```

The first line provides the version/revision and build information.

The second line starts the detailed status information for an individual resource. The individual field headings are as follows:

- cs: connection state
- st: node state (local/remote)
- ld: local data consistency
- ds: data consistency
- ns: network send
- nr: network receive
- dw: disk write
- dr: disk read
- pe: pending (waiting for ack)
- ua: unack'd (still need to send ack)
- al: access log write count

In the previous example, the information shown indicates that the nodes are connected, the local node is the primary (because it is listed first), and the local and remote data is up to date with each other. The remainder of the information is statistical data about the device, and the data exchanged that kept the information up to date.

You can also get the status information for DRBD by using the startup script with the `status` option:

```
root-shell> /etc/init.d/drbd status
* status: started
* drbd driver loaded OK: device status: ...
version: 8.3.0 (api:88/proto:86-89)
GIT-hash: 9ba8b93e24d842f0dd3fblf9b90e8348ddb95829 build by root@gentool.vmbear, 2009-03-14 23:00:06
0: cs:Connected ro:Secondary/Secondary ds:UpToDate/UpToDate C r---
ns:0 nr:0 dw:0 dr:8385604 al:0 bm:0 lo:0 pe:0 ua:0 ap:0 ep:1 wo:b oos:0
```

The information and statistics are the same.

2.1.6. Managing your DRBD Installation

For administration, the main command is `drbdadm`. There are a number of commands supported by this tool the control the connectivity and status of the DRBD devices.

Note

For convenience, a bash completion script is available that provides tab completion for options to `drbdadm`. The file `drbdadm.bash_completion` can be found within the standard DRBD source package within the `scripts` directory. To enable, copy the file to `/etc/bash_completion.d/drbdadm`. You can load it manually by using:

```
shell> source /etc/bash_completion.d/drbdadm
```

The most common commands are those to set the primary/secondary status of the local device. You can manually set this information for a number of reasons, including when you want to check the physical status of the secondary device (since you cannot mount a DRBD device in primary mode), or when you are temporarily moving the responsibility of keeping the data in check to a different machine (for example, during an upgrade or physical move of the normal primary node). You can set state of all local device to be the primary using this command:

```
root-shell> drbdadm primary all
```

Or switch the local device to be the secondary using:

```
root-shell> drbdadm secondary all
```

To change only a single DRBD resource, specify the resource name instead of `all`.

You can temporarily disconnect the DRBD nodes:

```
root-shell> drbdadm disconnect all
```

Reconnect them using `connect`:

```
root-shell> drbdadm connect all
```

For other commands and help with `drbdadm` see the DRBD documentation.

2.1.7. Additional DRBD Configuration Options

Additional options you may want to configure:

- `protocol`: Specifies the level of consistency to be used when information is written to the block device. The option is similar in principle to the `innodb_flush_log_at_trx_commit` option within MySQL. Three levels are supported:
 - **A**: Data is considered written when the information reaches the TCP send buffer and the local physical disk. There is no guarantee that the data has been written to the remote server or the remote physical disk.
 - **B**: Data is considered written when the data has reached the local disk and the remote node's network buffer. The data has reached the remote server, but there is no guarantee it has reached the remote server's physical disk.
 - **C**: Data is considered written when the data has reached the local disk and the remote node's physical disk.

The preferred and recommended protocol is C, as it is the only protocol which ensures the consistency of the local and remote physical storage.

- `size`: If you do not want to use the entire partition space with your DRBD block device then you can specify the size of the DRBD device to be created. The size specification can include a quantifier. For example, to set the maximum size of the DRBD partition to 1GB you would use:

```
size 1G;
```

With the configuration file suitably configured and ready to use, you now need to populate the lower-level device with the metadata information, and then start the DRBD service.

2.2. Configuring MySQL for DRBD

Once you have configured DRBD and have an active DRBD device and file system, you can configure MySQL to use the chosen device to store the MySQL data.

When performing a new installation of MySQL, you can either select to install MySQL entirely onto the DRBD device, or just configure the data directory to be located on the new file system.

In either case, the files and installation must take place on the primary node, because that is the only DRBD node on which you can mount the DRBD device file system as read/write.

Store the following files and information on your DRBD device:

- MySQL data files, including the binary log, and InnoDB data files.
- MySQL configuration file (`my.cnf`).

To set up MySQL to use your new DRBD device and file system:

1. If you are migrating an existing MySQL installation, stop MySQL:

```
shell> mysqladmin shutdown
```

2. Copy the `my.cnf` onto the DRBD device. If you are not already using a configuration file, copy one of the sample configuration files from the MySQL distribution.

```
root-shell> mkdir /mnt/drbd/mysql
root-shell> cp /etc/my.cnf /mnt/drbd/mysql
```

3. Copy your MySQL data directory to the DRBD device and mounted file system.

```
root-shell> cp -R /var/lib/mysql /drbd/mysql/data
```

4. Edit the configuration file to reflect the change of directory by setting the value of the `datadir` option. If you have not already enabled the binary log, also set the value of the `log-bin` option.

```
datadir = /drbd/mysql/data
log-bin = mysql-bin
```

5. Create a symbolic link from `/etc/my.cnf` to the new configuration file on the DRBD device file system.

```
root-shell> ln -s /drbd/mysql/my.cnf /etc/my.cnf
```

6. Now start MySQL and check that the data that you copied to the DRBD device file system is present.

```
root-shell> /etc/init.d/mysql start
```

Your MySQL data should now be located on the file system running on your DRBD device. The data is physically stored on the underlying device that you configured for the DRBD device. Meanwhile, the content of your MySQL databases is copied to the secondary DRBD node.

Note that you cannot access the information on your secondary node, as a DRBD device working in secondary mode is not available for use.

2.3. Optimizing Performance and Reliability

Because of the nature of the DRBD system, the critical requirements are for a very fast exchange of the information between the two hosts. To ensure that your DRBD setup is available to switch over in the event of a failure as quickly as possible, you must transfer the information between the two hosts using the fastest method available.

Typically, a dedicated network circuit should be used for exchanging DRBD data between the two hosts. Use a separate, additional, network interface for your standard network connection. For an example of this layout, see [Figure 2.2, “DRBD Architecture Using Separate Network Interfaces”](#).

Figure 2.2. DRBD Architecture Using Separate Network Interfaces

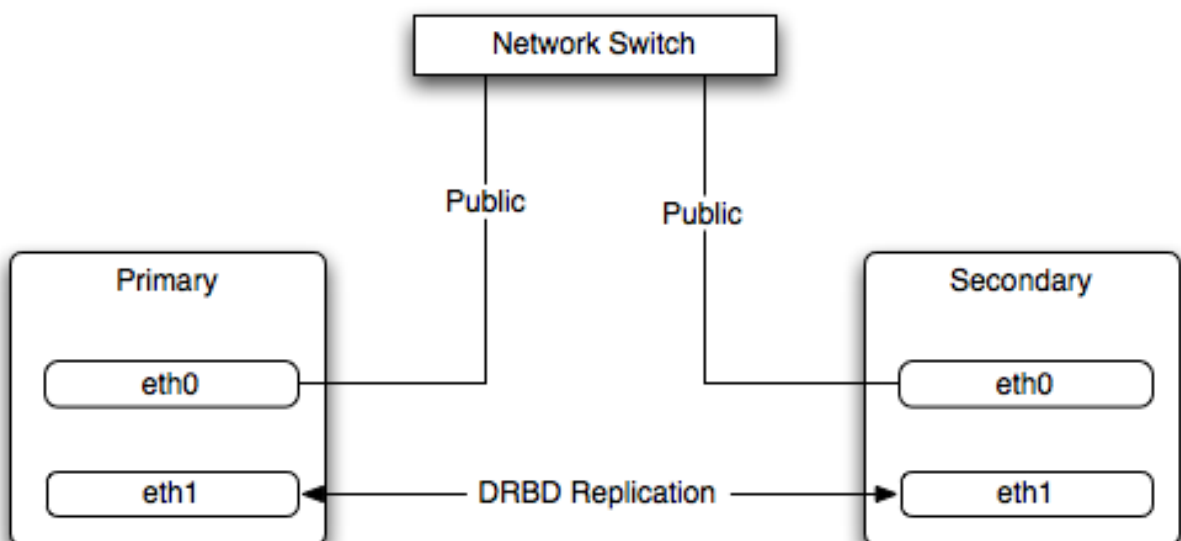

The dedicated DRBD network interfaces should be configured to use a nonrouted TCP/IP network configuration. For example, you might want to set the primary to use 192.168.0.1 and the secondary 192.168.0.2. These networks and IP addresses should not be part of normal network subnet.

Note

The preferred setup, whenever possible, is to use a direct cable connection (using a crossover cable with Ethernet, for example) between the two machines. This eliminates the risk of loss of connectivity due to switch failures.

2.3.1. Using Bonded Ethernet Network Interfaces

For a set-up where there is a high-throughput of information being written, you may want to use bonded network interfaces. This is where you combine the connectivity of more than one network port, increasing the throughput linearly according to the number of bonded connections.

Bonding also provides an additional benefit in that with multiple network interfaces effectively supporting the same communications channel, a fault within a single network interface in a bonded group does not stop communication. For example, imagine you have a bonded setup with four network interfaces providing a single interface channel between two DRBD servers. If one network interface fails, communication can continue on the other three without interruption, although at a lower speed.

To enable bonded connections you must enable bonding within the kernel. You then need to configure the module to specify the bonded devices and then configure each new bonded device just as you would a standard network device:

- To configure the bonded devices, edit the `/etc/modprobe.conf` file (RedHat) or add a file to the `/etc/modprobe.d` directory. In each case, you define the parameters for the kernel module. First, specify each bonding device:

```
alias bond0 bonding
```

You can then configure additional parameters for the kernel module. Typical parameters are the `mode` option and the `miimon` option.

The `mode` option specifies how the network interfaces are used. The default setting is 0, which means that each network interface is used in a round-robin fashion (this supports aggregation and fault tolerance). Using setting 1 sets the bonding mode to active-backup. This means that only one network interface is used as a time, but that the link automatically fails over to a new interface if the primary interface fails. This settings only supports fault-tolerance.

The `miimon` option enables the MII link monitoring. A positive value greater than zero indicates the monitoring frequency in milliseconds for checking each slave network interface that is configured as part of the bonded interface. A typical value is 100.

You set th options within the module parameter file, and you must set the options for each bonded device individually:

```
options bond0 miimon=100 mode=1
```

- Reboot your server to enable the bonded devices.
- Configure the network device parameters. There are two parts to this, you need to setup the bonded device configuration, and then configure the original network interfaces as 'slaves' of the new bonded interface.
- For RedHat Linux:

Edit the configuration file for the bonded device. For device `bond0` this would be `/etc/sysconfig/network-scripts/ifcfg-bond0`:

```
DEVICE=bond0
BOOTPROTO=none
ONBOOT=yes
GATEWAY=192.168.0.254
NETWORK=192.168.0.0
NETMASK=255.255.255.0
IPADDR=192.168.0.1
USERCTL=no
```

Then for each network interface that you want to be part of the bonded device, configure the interface as a slave to the 'master' bond. For example, the configuration of `eth0` in `/etc/sysconfig/network-scripts/ifcfg-eth0` might look like this::

```
DEVICE=eth0
BOOTPROTO=none
HWADDR=00:11:22:33:44:55
ONBOOT=yes
TYPE=Ethernet
MASTER=bond0
```

```
SLAVE=yes
```

- For Debian Linux:

Edit the `/etc/iftab` file and configure the logical name and MAC address for each devices. For example:

```
eth0 mac 00:11:22:33:44:55
```

Now you need to set the configuration of the devices in `/etc/network/interfaces`:

```
auto bond0
  iface bond0 inet static
  address 192.168.0.1
  netmask 255.255.255.0
  network 192.168.0.0
  gateway 192.168.0.254
  up /sbin/ifenslave bond0 eth0
  up /sbin/ifenslave bond0 eth1
```

- For Gentoo:

Use `emerge` to add the `net-misc/ifenslave` package to your system.

Edit the `/etc/conf.d/net` file and specify the network interface slaves in a bond, the dependencies and then the configuration for the bond itself. A sample configuration might look like this:

```
slaves_bond0="eth0 eth1 eth2"
config_bond0=( "192.168.0.1 netmask 255.255.255.0" )
depend_bond0() {
  need net.eth0 net.eth1 net.eth2
}
```

Then make sure that you add the new network interface to list of interfaces configured during boot:

```
root-shell> rc-update add default net.bond0
```

Once the bonded devices are configured, reboot your systems.

You can monitor the status of a bonded connection using the `/proc` file system:

```
root-shell> cat /proc/net/bonding/bond0
Bonding Mode: fault-tolerance (active-backup)
Primary Slave: None
Currently Active Slave: eth1
MII Status: up
MII Polling Interval (ms): 100
Up Delay (ms): 200
Down Delay (ms): 200
Slave Interface: eth1
MII Status: up
Link Failure Count: 0
Permanent HW addr: 00:11:22:33:44:55
Slave Interface: eth2
MII Status: up
Link Failure Count: 0
Permanent HW addr: 00:11:22:33:44:56
```

2.3.2. Optimizing the Synchronization Rate

The `syncer rate` configuration parameter should be configured with care as the synchronization rate can have a significant effect on the performance of the DRBD setup in the event of a node or disk failure where the information is being synchronized from the Primary to the Secondary node.

In DRBD, there are two distinct ways of data being transferred between peer nodes:

- *Replication* refers to the transfer of modified blocks being transferred from the primary to the secondary node. This happens automatically when the block is modified on the primary node, and the replication process uses whatever bandwidth is available over the replication link. The replication process cannot be throttled, because you want to transfer of the block information to happen as quickly as possible during normal operation.

- *Synchronization* refers to the process of bringing peers back in sync after some sort of outage, due to manual intervention, node failure, disk swap, or the initial setup. Synchronization is limited to the `syncer rate` configured for the DRBD device.

Both replication and synchronization can take place at the same time. For example, the block devices can be synchronized while they are actively being used by the primary node. Any I/O that updates on the primary node automatically triggers replication of the modified block. In the event of a failure within an HA environment, it is highly likely that synchronization and replication will take place at the same time.

Unfortunately, if the synchronization rate is set too high, then the synchronization process uses up all the available network bandwidth between the primary and secondary nodes. In turn, the bandwidth available for replication of changed blocks is zero, which stalls replication and blocks I/O, and ultimately the application fails or degrades.

To avoid enabling the `syncer rate` to consume the available network bandwidth and prevent the replication of changed blocks, set the `syncer rate` to less than the maximum network bandwidth.

Avoid setting the sync rate to more than 30% of the maximum bandwidth available to your device and network bandwidth. For example, if your network bandwidth is based on Gigabit ethernet, you should achieve 110MB/s. Assuming your disk interface is capable of handling data at 110MB/s or more, then the sync rate should be configured as `33M` (33MB/s). If your disk system works at a rate lower than your network interface, use 30% of your disk interface speed.

Depending on the application, you may wish to limit the synchronization rate. For example, on a busy server you may wish to configure a significantly slower synchronization rate to ensure the replication rate is not affected.

The `al-extents` parameter controls the number of 4MB blocks of the underlying disk that can be written to at the same time. Increasing this parameter lowers the frequency of the metadata transactions required to log the changes to the DRBD device, which in turn lowers the number of interruptions in your I/O stream when synchronizing changes. This can lower the latency of changes to the DRBD device. However, if a crash occurs on your primary, then all of the blocks in the activity log (that is, the number of `al-extents` blocks) must be completely resynchronized before replication can continue.

Chapter 3. Using Linux HA Heartbeat

The Heartbeat program provides a basis for verifying the availability of resources on one or more systems within a cluster. In this context a resource includes MySQL, the file systems on which the MySQL data is being stored and, if you are using DRBD, the DRBD device being used for the file system. Heartbeat also manages a virtual IP address, and the virtual IP address should be used for all communication to the MySQL instance.

A cluster within the context of Heartbeat is defined as two computers notionally providing the same service. By definition, each computer in the cluster is physically capable of providing the same services as all the others in the cluster. However, because the cluster is designed for high-availability, only one of the servers is actively providing the service at any one time. Each additional server within the cluster is a “hot-spare” that can be brought into service in the event of a failure of the master, its next connectivity or the connectivity of the network in general.

The basics of Heartbeat are very simple. Within the Heartbeat cluster (see [Figure 3.1, “Heartbeat Architecture”](#)), each machine sends a ‘heartbeat’ signal to the other hosts in the cluster. The other cluster nodes monitor this heartbeat. The heartbeat can be transmitted over many different systems, including shared network devices, dedicated network interfaces and serial connections. Failure to get a heartbeat from a node is treated as failure of the node. Although we do not know the reason for the failure (it could be an OS failure, a hardware failure in the server, or a failure in the network switch), it is safe to assume that if no heartbeat is produced there is a fault.

Figure 3.1. Heartbeat Architecture

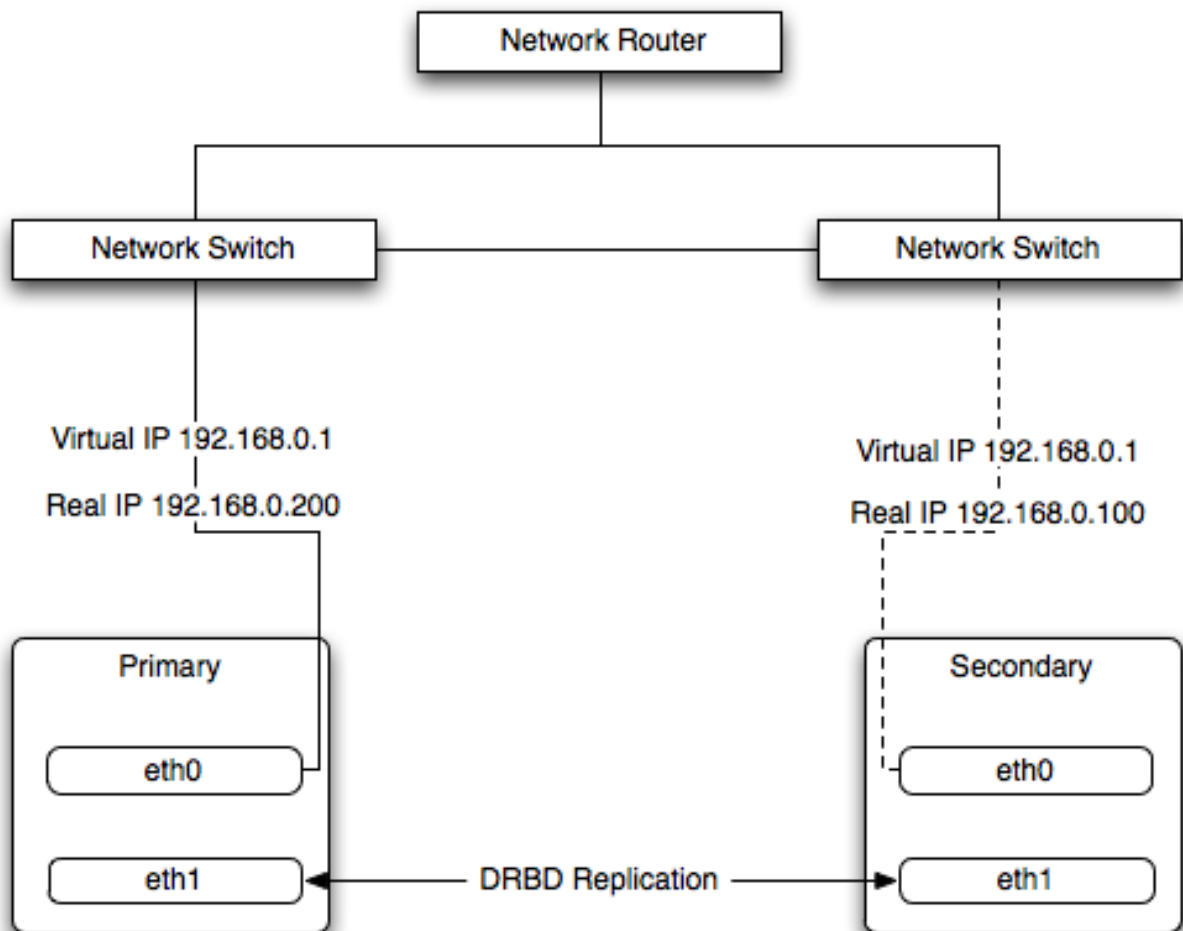

In addition to checking the heartbeat from the server, the system can also check the connectivity (using `ping`) to another host on the network, such as the network router. This enables Heartbeat to detect a failure of communication between a server and the router (and therefore failure of the server, since it is no longer capable of providing the necessary service), even if the heartbeat between the servers in the clusters is working fine.

In the event of a failure, the resources on the failed host are disabled, and the resources on one of the replacement hosts is enabled instead. In addition, the Virtual IP address for the cluster is redirected to the new host in place of the failed device.

When used with MySQL and DRBD, the MySQL data is replicated from the master to the slave using the DRBD device, but MySQL is only running on the master. When the master fails, the slave switches the DRBD devices to be primary, the file systems on those devices are mounted, and MySQL is started. The original master (if still available) has its resources disabled, which means shutting down MySQL and unmounting the file systems and switching the DRBD device to secondary.

3.1. Heartbeat Configuration

Heartbeat configuration requires three files located in `/etc/ha.d`. The `ha.cf` contains the main heartbeat configuration, including the list of the nodes and times for identifying failures. `haresources` contains the list of resources to be managed within the cluster. The `authkeys` file contains the security information for the cluster.

The contents of these files should be identical on each host within the Heartbeat cluster. It is important that you keep these files in sync across all the hosts. Any changes in the information on one host should be copied to the all the others.

For these examples an example of the `ha.cf` file is shown below:

```
logfacility local0
keepalive 500ms
deadtime 10
warntime 5
initdead 30
mcast bond0 225.0.0.1 694 2 0
mcast bond1 225.0.0.2 694 1 0
auto_failback off
node drbd1
node drbd2
```

The individual lines in the file can be identified as follows:

- `logfacility`: Sets the logging, in this case setting the logging to use `syslog`.
- `keepalive`: Defines how frequently the heartbeat signal is sent to the other hosts.
- `deadtime`— the delay in seconds before other hosts in the cluster are considered 'dead' (failed).
- `warntime`: The delay in seconds before a warning is written to the log that a node cannot be contacted.
- `initdead`: The period in seconds to wait during system startup before the other host is considered to be down.
- `mcast`: Defines a method for sending a heartbeat signal. In the above example, a multicast network address is being used over a bonded network device. If you have multiple clusters then the multicast address for each cluster should be unique on your network. Other choices for the heartbeat exchange exist, including a serial connection.

If you are using multiple network interfaces (for example, one interface for your server connectivity and a secondary or bonded interface for your DRBD data exchange), use both interfaces for your heartbeat connection. This decreases the chance of a transient failure causing an invalid failure event.

- `auto_failback`: Sets whether the original (preferred) server should be enabled again if it becomes available. Switching this to `on` may cause problems if the preferred went offline and then comes back on line again. If the DRBD device has not been synced properly, or if the problem with the original server happens again you may end up with two different datasets on the two servers, or with a continually changing environment where the two servers flip-flop as the preferred server reboots and then starts again.
- `node`: Sets the nodes within the Heartbeat cluster group. There should be one `node` for each server.

An optional additional set of information provides the configuration for a ping test that checks the connectivity to another host. Use this to ensure that you have connectivity on the public interface for your servers, so the ping test should be to a reliable host such as a router or switch. The additional lines specify the destination machine for the `ping`, which should be specified as an IP address, rather than a host name; the command to run when a failure occurs, the authority for the failure and the timeout before a non-response triggers a failure. A sample configure is shown below:

```
ping 10.0.0.1
respawn hacluster /usr/lib64/heartbeat/ipfail
apiauth ipfail gid=haclient uid=hacluster
deadping 5
```

In the above example, the `ipfail` command, which is part of the Heartbeat solution, is called on a failure and 'fakes' a fault on the currently active server. You need to configure the user and group ID under which the command is executed (using the `apiauth`).

The failure is triggered after 5 seconds.

Note

The `deadping` value must be less than the `deadtime` value.

The `authkeys` file holds the authorization information for the Heartbeat cluster. The authorization relies on a single unique 'key' that is used to verify the two machines in the Heartbeat cluster. The file is used only to confirm that the two machines are in the same cluster and is used to ensure that the multiple clusters can co-exist within the same network.

3.2. Using Heartbeat with MySQL and DRBD

To use Heartbeat in combination with MySQL, use DRBD (see [Chapter 2, Using MySQL with DRBD](#)) or another solution that enables sharing the MySQL database files in event of a system failure. In these examples, DRBD is used as the data sharing solution.

Heartbeat manages the configuration of different resources to manage the switching between two servers in the event of a failure. The resource configuration defines the individual services that should be brought up (or taken down) in the event of a failure.

The `haresources` file within `/etc/ha.d` defines the resources that should be managed, and the individual resource mentioned in this file in turn relates to scripts located within `/etc/ha.d/resource.d`. The resource definition is defined all on one line:

```
drbd1 drbddisk Filesystem::/dev/drbd0::/drbd::ext3 mysql 10.0.0.100
```

The line is notionally split by whitespace. The first entry (`drbd1`) is the name of the preferred host; that is the server that is normally responsible for handling the service. The last field is virtual IP address or name that should be used to share the service. This is the IP address that should be used to connect to the MySQL server. It is automatically allocated to the server that is active when Heartbeat starts.

The remaining fields between these two fields define the resources that should be managed. Each Field should contain the name of the resource (and each name should refer to a script within `/etc/ha.d/resource.d`). In the event of a failure, these resources are started on the backup server by calling the corresponding script (with a single argument, `start`), in order from left to right. If there are additional arguments to the script, you can use a double colon to separate each additional argument.

In the above example, we manage the following resources:

- `drbddisk`: The DRBD resource script, this switches the DRBD disk on the secondary host into primary mode, making the device read/write.
- `Filesystem`: Manages the Filesystem resource. In this case we have supplied additional arguments to specify the DRBD device, mount point and file system type. When executed this should mount the specified file system.
- `mysql`: Manages the MySQL instances and starts the MySQL server. Copy the `mysql.resource` file from the `support-files` directory from any MySQL release into the `/etc/ha.d/resources.d` directory.

If this file is not available in your distribution, you can use the following as the contents of the `/etc/ha.d/resource.d/mysql.resource` file:

```
#!/bin/bash
#
# This script is intended to be used as resource script by heartbeat
#
# Mar 2006 by Monty Taylor
#
###
. /etc/ha.d/shellfuncs
case "$1" in
  start)
    res=`/etc/init.d/mysql start`
    ret=$?
    ha_log $res
    exit $ret
    ;;
  stop)
    res=`/etc/init.d/mysql stop`
    ret=$?
    ha_log $res
    exit $ret
    ;;
  status)
    if [[ `ps -ef | grep '[m]ysqld'` > 1 ]] ; then
      echo "running"
    else
      echo "stopped"
    fi
    ;;
  *)
    echo "Usage: mysql {start|stop|status}"
    exit 1

```

```
;;
esac
exit 0
```

If you want to be notified of the failure by email, you can add another line to the `haresources` file with the address for warnings and the warning text:

```
MailTo:youremail@address.com:DRBDFailure
```

With the Heartbeat configuration in place, copy the `haresources`, `authkeys` and `ha.cf` files from your primary and secondary servers to make sure that the configuration is identical. Then start the Heartbeat service, either by calling `/etc/init.d/heartbeat start` or by rebooting both primary and secondary servers.

You can test the configuration by running a manual failover, connect to the primary node and run:

```
root-shell> /usr/lib64/heartbeat/hb_standby
```

This causes the current node to relinquish its resources cleanly to the other node.

3.3. Using Heartbeat with DRBD and `dopd`

As a further extension to using DRBD and Heartbeat together, you can enable `dopd`. The `dopd` daemon handles the situation where a DRBD node is out of date compared to the master and prevents the slave from being promoted to master in the event of a failure. This stops a situation where you have two machines that have been masters ending up different data on the underlying device.

For example, imagine that you have a two server DRBD setup, master and slave. If the DRBD connectivity between master and slave fails, then the slave is out of the sync with the master. If Heartbeat identifies a connectivity issue for master and then switches over to the slave, the slave DRBD device is promoted to the primary device, even though the data on the slave and the master is not in synchronization.

In this situation, with `dopd` enabled, the connectivity failure between the master and slave would be identified and the metadata on the slave would be set to `Outdated`. Heartbeat refuses to switch over to the slave even if the master failed. In a dual-host solution this would effectively render the cluster out of action, as there is no additional fail over server. In an HA cluster with three or more servers, control would be passed to the slave that has an up to date version of the DRBD device data.

To enable `dopd`, you need to modify the Heartbeat configuration and specify `dopd` as part of the commands executed during the monitoring process. Add the following lines to your `ha.cf` file:

```
respawn hacluster /usr/lib/heartbeat/dopd
apiauth dopd gid=haclient uid=hacluster
```

Make sure you make the same modification on both your primary and secondary nodes.

Reload the Heartbeat configuration:

```
root-shell> /etc/init.d/heartbeat reload
```

Modify your DRBD configuration by configuration the `outdate-peer` option. Add the configuration line into the `common` section of `/etc/drbd.conf` on both hosts. An example of the full block is shown below:

```
common {
  handlers {
    outdate-peer "/usr/lib/heartbeat/drbd-peer-outdater";
  }
}
```

Finally, set the `fencing` option on your DRBD configured resources:

```
resource my-resource {
  disk {
    fencing resource-only;
  }
}
```

Now reload your DRBD configuration:

```
root-shell> drbdadmin adjust all
```

You can test the system by unplugging your DRBD link and monitoring the output from `/proc/drbd`.

3.4. Dealing with System Level Errors

Because a kernel panic or oops may indicate potential problem with your server, configure your server to remove itself from the cluster in the event of a problem. Typically on a kernel panic, your system automatically triggers a hard reboot. For a kernel oops, a reboot may not happen automatically, but the issue that caused that oops may still lead to potential problems.

You can force a reboot by setting the `kernel.panic` and `kernel.panic_on_oops` parameters of the kernel control file `/etc/sysctl.conf`. For example:

```
kernel.panic_on_oops = 1
kernel.panic = 1
```

You can also set these parameters during runtime by using the `sysctl` command. You can either specify the parameters on the command line:

```
shell> sysctl -w kernel.panic=1
```

Or you can edit your `sysctl.conf` file and then reload the configuration information:

```
shell> sysctl -p
```

Setting both these parameters to a positive value (representing the number of seconds to wait before rebooting), causes the system to reboot. Your second heartbeat node should then detect that the server is down and then switch over to the failover host.

Chapter 4. Using MySQL with memcached

The largest problem with scalability within a typical environment is the speed with which you can access information. For frequently accessed information, using MySQL can be slow because each access of information requires execution of the SQL query and recovery of the information from the database. This also means that queries on tables that are locked or blocking may delay your query and reduce the speed of recovery of information.

`memcached` is a simple, yet highly scalable key-based cache that stores data and objects wherever dedicated or spare RAM is available for very quick access by applications. To use, you run `memcached` on one or more hosts and then use the shared cache to store objects. Because each host's RAM is storing information, the access speed is much faster than loading the information from disk. This can provide a significant performance boost in retrieving data versus loading the data natively from a database. Also, because the cache is just a repository for information, you can use the cache to store any data, including complex structures that would normally require a significant amount of effort to create, but in a ready-to-use format, helping to reduce the load on your MySQL servers.

The typical usage environment is to modify your application so that information is read from the cache provided by `memcached`. If the information isn't in `memcached`, then the data is loaded from the MySQL database and written into the cache so that future requests for the same object benefit from the cached data.

For a typical deployment layout, see [Figure 4.1, “memcached Architecture Overview”](#).

Figure 4.1. memcached Architecture Overview

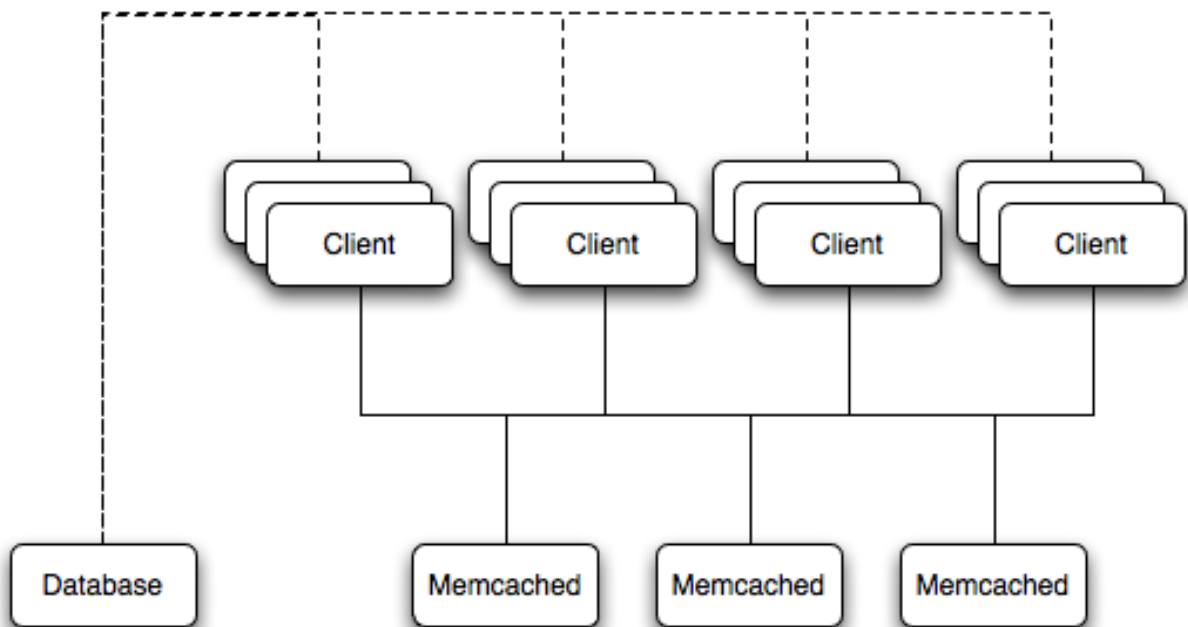

In the example structure, any of the clients can contact one of the `memcached` servers to request a given key. Each client is configured to talk to all of the servers shown in the illustration. Within the client, when the request is made to store the information, the key used to reference the data is hashed and this hash is then used to select one of the `memcached` servers. The selection of the `memcached` server takes place on the client before the server is contacted, keeping the process lightweight.

The same algorithm is used again when a client requests the same key. The same key generates the same hash, and the same `memcached` server is selected as the source for the data. Using this method, the cached data is spread among all of the `memcached` servers, and the cached information is accessible from any client. The result is a distributed, memory-based, cache that can return information, particularly complex data and structures, much faster than natively reading the information from the database.

The data held within a `memcached` server is never stored on disk (only in RAM, which means there is no persistence of data), and the RAM cache is always populated from the backing store (a MySQL database). If a `memcached` server fails, the data can always be recovered from the MySQL database, albeit at a slower speed than loading the information from the cache.

4.1. Installing memcached

You can build and install `memcached` from the source code directly, or you can use an existing operating system package or installation.

Installing `memcached` from a Binary Distribution

To install `memcached` on a RedHat, or Fedora host, use `yum`:

```
root-shell> yum install memcached
```

Note

On CentOS, you may be able to obtain a suitable RPM from another source, or use the source tarball.

To install `memcached` on a Debian or Ubuntu host, use `apt-get`:

```
root-shell> apt-get install memcached
```

To install `memcached` on a Gentoo host, use `emerge`:

```
root-shell> emerge install memcached
```

Building `memcached` from Source

On other Unix-based platforms, including Solaris, AIX, HP-UX and Mac OS X, and Linux distributions not mentioned already, you must install from source. For Linux, make sure you have a 2.6-based kernel, which includes the improved `epoll` interface. For all platforms, ensure that you have `libevent` 1.1 or higher installed. You can obtain `libevent` from [libevent web page](#).

You can obtain the source for `memcached` from [memcached Web site](#).

To build `memcached`, follow these steps:

1. Extract the `memcached` source package:

```
shell> gunzip -c memcached-1.2.5.tar.gz | tar xf -
```

2. Change to the `memcached-1.2.5` directory:

```
shell> cd memcached-1.2.5
```

3. Run `configure`

```
shell> ./configure
```

Some additional options you may want to specify to `configure`:

- `--prefix`

If you want to specify a different installation directory, use the `--prefix` option:

```
shell> ./configure --prefix=/opt
```

The default is to use the `/usr/local` directory.

- `--with-libevent`

If you have installed `libevent` and `configure` cannot find the library, use the `--with-libevent` option to specify the location of the installed library.

- `--enable-64bit`

To build a 64-bit version of `memcached` (which enables you to use a single instance with a large RAM allocation), use `--enable-64bit`.

- `--enable-threads`

To enable multi-threading support in `memcached`, which improves the response times on servers with a heavy load, use `--enable-threads`. You must have support for the POSIX threads within your operating system to enable thread sup-

port. For more information on the threading support, see [Section 4.2.7, “memcached thread Support”](#).

- `--enable-dtrace`

`memcached` includes a range of DTrace threads that can be used to monitor and benchmark a `memcached` instance. For more information, see [Section 4.2.5, “Using memcached and DTrace”](#).

4. Run `make` to build `memcached`:

```
shell> make
```

5. Run `make install` to install `memcached`:

```
shell> make install
```

4.2. Using memcached

To start using `memcached`, you must start the `memcached` service on one or more servers. Running `memcached` sets up the server, allocates the memory and starts listening for connections from clients.

Note

You do not need to be privileged user (`root`) to run `memcached` unless you want to listen on one of the privileged TCP/IP ports (below 1024). You must, however, use a user that has not had their memory limits restricted using `setrlimit` or similar.

To start the server, run `memcached` as a nonprivileged (that is, non-`root`) user:

```
shell> memcached
```

By default, `memcached` uses the following settings:

- Memory allocation of 64MB
- Listens for connections on all network interfaces, using port 11211
- Supports a maximum of 1024 simultaneous connections

Typically, you would specify the full combination of options that you want when starting `memcached`, and normally provide a startup script to handle the initialization of `memcached`. For example, the following line starts `memcached` with a maximum of 1024MB RAM for the cache, listening on port 11211 on the IP address 192.168.0.110, running as a background daemon:

```
shell> memcached -d -m 1024 -p 11211 -l 192.168.0.110
```

To ensure that `memcached` is started up on boot, check the init script and configuration parameters.

`memcached` supports the following options:

- `-u user`

If you start `memcached` as `root`, use the `-u` option to specify the user for executing `memcached`:

```
shell> memcached -u memcache
```

- `-m memory`

Set the amount of memory allocated to `memcached` for object storage. Default is 64MB.

To increase the amount of memory allocated for the cache, use the `-m` option to specify the amount of RAM to be allocated (in megabytes). The more RAM you allocate, the more data you can store and therefore the more effective your cache is.

Warning

Do not specify a memory allocation larger than your available RAM. If you specify too large a value, then some RAM

allocated for memcached uses swap space, and not physical RAM. This may lead to delays when storing and retrieving values, because data is swapped to disk, instead of storing the data directly in RAM.

You can use the output of the `vmstat` command to get the free memory, as shown in `free` column:

```
shell> vmstat
kthr    memory                page            disk            faults          cpu
r  b  w    swap  free  re  mf  pi  po  fr  de  sr  sl  s2  --  --  in  sy  cs  us  sy  id
0  0  0  5170504 3450392 2  7  2  0  0  0  4  0  0  0  0  296  54  199  0  0  100
```

For example, to allocate 3GB of RAM:

```
shell> memcached -m 3072
```

On 32-bit x86 systems where you are using PAE to access memory above the 4GB limit, you cannot allocate RAM beyond the maximum process size. You can get around this by running multiple instances of memcached, each listening on a different port:

```
shell> memcached -m 1024 -p11211
shell> memcached -m 1024 -p11212
shell> memcached -m 1024 -p11213
```

Note

On all systems, particularly 32-bit, ensure that you leave enough room for both memcached application in addition to the memory setting. For example, if you have a dedicated memcached host with 4GB of RAM, do not set the memory size above 3500MB. Failure to do this may cause either a crash or severe performance issues.

- `-l interface`

Specify a network interface/address to listen for connections. The default is to listen on all available address (`INADDR_ANY`).

```
shell> memcached -l 192.168.0.110
```

Support for IPv6 address support was added in memcached 1.2.5.

- `-p port`

Specify the TCP port to use for connections. Default is 18080.

```
shell> memcached -p 18080
```

- `-U port`

Specify the UDP port to use for connections. Default is 11211, 0 switches UDP off.

```
shell> memcached -U 18080
```

- `-s socket`

Specify a Unix socket to listen on.

If you are running memcached on the same server as the clients, you can disable the network interface and use a local UNIX socket using the `-s` option:

```
shell> memcached -s /tmp/memcached
```

Using a UNIX socket automatically disables network support, and saves network ports (allowing more ports to be used by your web server or other process).

- `-a mask`

Specify the access mask to be used for the Unix socket, in octal. Default is 0700.

- `-c connections`

Specify the maximum number of simultaneous connections to the memcached service. The default is 1024.

```
shell> memcached -c 2048
```

Use this option, either to reduce the number of connections (to prevent overloading memcached service) or to increase the number to make more effective use of the server running memcached server.

- `-t threads`

Specify the number of threads to use when processing incoming requests.

By default, memcached is configured to use 4 concurrent threads. The threading improves the performance of storing and retrieving data in the cache, using a locking system to prevent different threads overwriting or updating the same values. You may want to increase or decrease the number of threads, use the `-t` option:

```
shell> memcached -t 8
```

- `-d`

Run memcached as a daemon (background) process:

```
shell> memcached -d
```

- `-r`

Maximize the size of the core file limit. In the event of a failure, this attempts to dump the entire memory space to disk as a core file, up to any limits imposed by `setrlimit`.

- `-M`

Return an error to the client when the memory has been exhausted. This replaces the normal behavior of removing older items from the cache to make way for new items.

- `-k`

Lock down all paged memory. This reserves the memory before use, instead of allocating new slabs of memory as new items are stored in the cache.

Note

There is a user-level limit on how much memory you can lock. Trying to allocate more than the available memory fails. You can set the limit for the user you started the daemon with (not for the `-u user` user) within the shell by using `ulimit -S -l NUM_KB`

- `-v`

Verbose mode. Prints errors and warnings while executing the main event loop.

- `-vv`

Very verbose mode. In addition to information printed by `-v`, also prints each client command and the response.

- `-vvv`

Extremely verbose mode. In addition to information printed by `-vv`, also show the internal state transitions.

- `-h`

Print the help message and exit.

- `-i`

Print the memcached and libevent license.

- `-I mem`

Specify the maximum size permitted for storing an object within the memcached instance. The size supports a unit postfix (`k` for kilobytes, `m` for megabytes). For example, to increase the maximum supported object size to 32MB:

```
shell> memcached -I 32m
```

The maximum object size you can specify is 128MB, the default remains at 1MB.

This option was added in 1.4.2.

- `-b`

Set the backlog queue limit. The backlog queue configures how many network connections can be waiting to be processed by memcached. Increasing this limit may reduce errors received by the client that it is not able to connect to the memcached instance, but does not improve the performance of the server. The default is 1024.

- `-P pidfile`

Save the process ID of the memcached instance into file.

- `-f`

Set the chunk size growth factor. When allocating new memory chunks, the allocated size of new chunks is determined by multiplying the default slab size by this factor.

To see the effects of this option without extensive testing, use the `-vv` command-line option to show the calculated slab sizes. For more information, see [Section 4.2.8, “memcached Logs”](#).

- `-n bytes`

The minimum space allocated for the key+value+flags information. The default is 48 bytes.

- `-L`

On systems that support large memory pages, enables large memory page use. Using large memory pages enables memcached to allocate the item cache in one large chunk, which can improve the performance by reducing the number misses when accessing memory.

- `-C`

Disable the use of compare and swap (CAS) operations.

This option was added in memcached 1.3.x.

- `-D char`

Set the default character to be used as a delimiter between the key prefixes and IDs. This is used for the per-prefix statistics reporting (see [Section 4.4, “Getting memcached Statistics”](#)). The default is the colon (:). If this option is used, statistics collection is turned on automatically. If not used, you can enable stats collection by sending the `stats detail on` command to the server.

This option was added in memcached 1.3.x.

- `-R num`

Sets the maximum number of requests per event process. The default is 20.

- `-B protocol`

Set the binding protocol, that is, the default memcached protocol support for client connections. Options are `ascii`, `binary` or `auto`. Automatic (`auto`) is the default.

This option was added in memcached 1.4.0.

4.2.1. memcached Deployment

When using memcached you can use a number of different potential deployment strategies and topologies. The exact strategy to use depends on your application and environment. When developing a system for deploying memcached within your system, keep in mind the following points:

- memcached is only a caching mechanism. It shouldn't be used to store information that you cannot otherwise afford to lose and then load from a different location.
- There is no security built into the memcached protocol. At a minimum, make sure that the servers running memcached are only accessible from inside your network, and that the network ports being used are blocked (using a firewall or similar). If the information on the memcached servers that is being stored is any sensitive, then encrypt the information before storing it in

`memcached`.

- `memcached` does not provide any sort of failover. Because there is no communication between different `memcached` instances. If an instance fails, your application must be capable of removing it from the list, reloading the data and then writing data to another `memcached` instance.
- Latency between the clients and the `memcached` can be a problem if you are using different physical machines for these tasks. If you find that the latency is a problem, move the `memcached` instances to be on the clients.
- Key length is determined by the `memcached` server. The default maximum key size is 250 bytes.
- Using a single `memcached` instance, especially for multiple clients, is generally a bad idea as it introduces a single point of failure. Instead provide at least two `memcached` instances so that a failure can be handled appropriately. If possible, you should create as many `memcached` nodes as possible. When adding and removing `memcached` instances from a pool, the hashing and distribution of key/value pairs may be affected. For information on how to avoid problems, see [Section 4.2.4, “memcached Hashing/Distribution Types”](#).

4.2.2. Using namespaces

The `memcached` cache is a very simple massive key/value storage system, and as such there is no way of compartmentalizing data automatically into different sections. For example, if you are storing information by the unique ID returned from a MySQL database, then storing the data from two different tables could run into issues because the same ID might be valid in both tables.

Some interfaces provide an automated mechanism for creating *namespaces* when storing information into the cache. In practice, these namespaces are merely a prefix before a given ID that is applied every time a value is stored or retrieved from the cache.

You can implement the same basic principle by using keys that describe the object and the unique identifier within the key that you supply when the object is stored. For example, when storing user data, prefix the ID of the user with `user:` or `user-`.

Note

Using namespaces or prefixes only controls the keys stored/retrieved. There is no security within `memcached`, and therefore no way to enforce that a particular client only accesses keys with a particular namespace. Namespaces are only useful as a method of identifying data and preventing corruption of key/value pairs.

4.2.3. Data Expiry

There are two types of data expiry within a `memcached` instance. The first type is applied at the point when you store a new key/value pair into the `memcached` instance. If there is not enough space within a suitable slab to store the value, then an existing least recently used (LRU) object is removed (evicted) from the cache to make room for the new item.

The LRU algorithm ensures that the object that is removed is one that is either no longer in active use or that was used so long ago that its data is potentially out of date or of little value. However, in a system where the memory allocated to `memcached` is smaller than the number of regularly used objects required in the cache, a lot of expired items could be removed from the cache even though they are in active use. You use the statistics mechanism to get a better idea of the level of evictions (expired objects). For more information, see [Section 4.4, “Getting memcached Statistics”](#).

You can change this eviction behavior by setting the `-M` command-line option when starting `memcached`. This option forces an error to be returned when the memory has been exhausted, instead of automatically evicting older data.

The second type of expiry system is an explicit mechanism that you can set when a key/value pair is inserted into the cache, or when deleting an item from the cache. Using an expiration time can be a useful way of ensuring that the data in the cache is up to date and in line with your application needs and requirements.

A typical scenario for explicitly setting the expiry time might include caching session data for a user when accessing a Web site. `memcached` uses a lazy expiry mechanism where the explicit expiry time that has been set is compared with the current time when the object is requested. Only objects that have not expired are returned.

You can also set the expiry time when explicitly deleting an object from the cache. In this case, the expiry time is really a timeout and indicates the period when any attempts to set the value for a given key are rejected.

4.2.4. `memcached` Hashing/Distribution Types

The `memcached` client interface supports a number of different distribution algorithms that are used in multi-server configurations to determine which host should be used when setting or getting data from a given `memcached` instance. When you get or set a value, a hash is constructed from the supplied key and then used to select a host from the list of configured servers. Because the hashing mechanism uses the supplied key as the basis for the hash, the same server is selected during both set and get operations.

You can think of this process as follows. Given an array of servers (a, b, and c), the client uses a hashing algorithm that returns an integer based on the key being stored or retrieved. The resulting value is then used to select a server from the list of servers configured in the client. Most standard client hashing within memcache clients uses a simple modulus calculation on the value against the number of configured memcached servers. You can summarize the process in pseudocode as:

```
@memcservers = ['a.memc', 'b.memc', 'c.memc'];
$value = hash($key);
$chosen = $value % length(@memcservers);
```

Replacing the above with values:

```
@memcservers = ['a.memc', 'b.memc', 'c.memc'];
$value = hash('myid');
$chosen = 7009 % 3;
```

In the above example, the client hashing algorithm chooses the server at index 1 ($7009 \% 3 = 1$), and store or retrieve the key and value with that server.

Note

This selection and hashing process is handled automatically by the memcached client you are using; you need only provide the list of memcached servers that you want to use.

You can see a graphical representation of this below in [Figure 4.2, “memcached Hash Selection”](#).

Figure 4.2. memcached Hash Selection

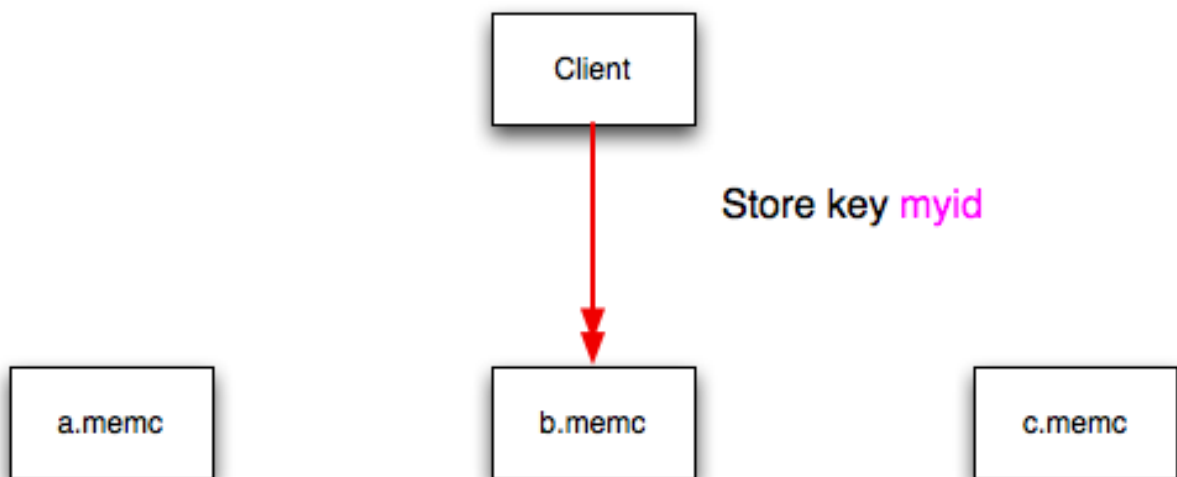

The same hashing and selection process takes place during any operation on the specified key within the memcached client.

Using this method provides a number of advantages:

- The hashing and selection of the server to contact is handled entirely within the client. This eliminates the need to perform network communication to determine the right machine to contact.
- Because the determination of the memcached server occurs entirely within the client, the server can be selected automatically regardless of the operation being executed (set, get, increment, etc.).
- Because the determination is handled within the client, the hashing algorithm returns the same value for a given key; values are not affected or reset by differences in the server environment.
- Selection is very fast. The hashing algorithm on the key value is quick and the resulting selection of the server is from a simple array of available machines.
- Using client-side hashing simplifies the distribution of data over each memcached server. Natural distribution of the values returned by the hashing algorithm means that keys are automatically spread over the available servers.

Providing that the list of servers configured within the client remains the same, the same stored key returns the same value, and therefore selects the same server.

However, if you do not use the same hashing mechanism then the same data may be recorded on different servers by different interfaces, both wasting space on your memcached and leading to potential differences in the information.

Note

One way to use a multi-interface compatible hashing mechanism is to use the `libmemcached` library and the associated interfaces. Because the interfaces for the different languages (including C, Ruby, Perl and Python) use the same client library interface, they always generate the same hash code from the ID.

The problem with client-side selection of the server is that the list of the servers (including their sequential order) *must* remain consistent on each client using the memcached servers, and the servers must be available. If you try to perform an operation on a key when:

- A new memcached instance has been added to the list of available instances
- A memcached instance has been removed from the list of available instances
- The order of the memcached instances has changed

When the hashing algorithm is used on the given key, but with a different list of servers, the hash calculation may choose a different server from the list.

If a new memcached instance is added into the list of servers, as `new.memc` is in the example below, then a GET operation using the same key, `myid`, can result in a cache-miss. This is because the same value is computed from the key, which selects the same index from the array of servers, but index 2 now points to the new server, not the server `c.memc` where the data was originally stored. This would result in a cache miss, even though the key exists within the cache on another memcached instance.

Figure 4.3. memcached Hash Selection with New memcached instance

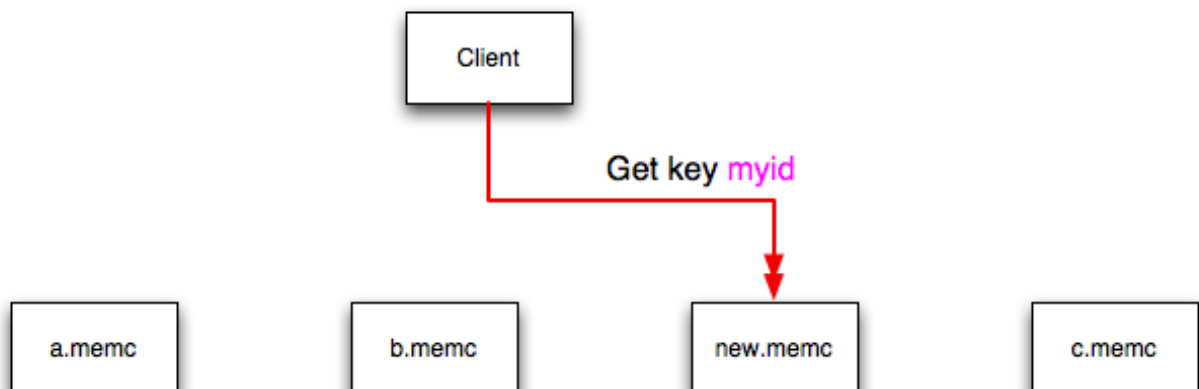

This means that servers `c.memc` and `new.memc` both contain the information for key `myid`, but the information stored against the key in each server may be different in each instance. A more significant problem is a much higher number of cache-misses when retrieving data, as the addition of a new server changes the distribution of keys, and this in turn requires rebuilding the cached data on the memcached instances, causing an increase in database reads.

The same effect can occur if you actively manage the list of servers configured in your clients, adding and removing the configured memcached instances as each instance is identified as being available. For example, removing a memcached instance when the client notices that the instance can no longer be contacted can cause the server selection to fail as described here.

To prevent this causing significant problems and invalidating your cache, you can select the hashing algorithm used to select the server. There are two common types of hashing algorithm, *consistent* and *modula*.

With *consistent* hashing algorithms, the same key when applied to a list of servers always uses the same server to store or retrieve the keys, even if the list of configured servers changes. This means that you can add and remove servers from the configure list and always use the same server for a given key. There are two types of consistent hashing algorithms available, Ketama and Wheel. Both types are supported by `libmemcached`, and implementations are available for PHP and Java.

Any consistent hashing algorithm has some limitations. When you add servers to an existing list of configured servers, keys are distributed to the new servers as part of the normal distribution. When you remove servers from the list, the keys are re-allocated to another server within the list, meaning that the cache needs to be re-populated with the information. Also, a consistent hashing algorithm does not resolve the issue where you want consistent selection of a server across multiple clients, but where each client contains a different list of servers. The consistency is enforced only within a single client.

With a *modula* hashing algorithm, the client selects a server by first computing the hash and then choosing a server from the list of configured servers. As the list of servers changes, so the server selected when using a modula hashing algorithm also changes. The result is the behavior described above; changes to the list of servers mean that different servers are selected when retrieving data, leading to cache misses and increase in database load as the cache is re-seeded with information.

If you use only a single `memcached` instance for each client, or your list of `memcached` servers configured for a client never changes, then the selection of a hashing algorithm is irrelevant, as it has no noticeable effect.

If you change your servers regularly, or you use a common set of servers that are shared among a large number of clients, then using a consistent hashing algorithm should help to ensure that your cache data is not duplicated and the data is evenly distributed.

4.2.5. Using `memcached` and DTrace

`memcached` includes a number of different DTrace probes that can be used to monitor the operation of the server. The probes included can monitor individual connections, slab allocations, and modifications to the hash table when a key/value pair is added, updated, or removed.

For more information on DTrace and writing DTrace scripts, read the [DTrace User Guide](#).

Support for DTrace probes was added to `memcached` 1.2.6 includes a number of DTrace probes that can be used to help monitor your application. DTrace is supported on Solaris 10, OpenSolaris, Mac OS X 10.5 and FreeBSD. To enable the DTrace probes in `memcached`, build from source and use the `--enable-dtrace` option. For more information, see [Section 4.1, "Installing memcached"](#).

The probes supported by `memcached` are:

- `conn-allocate(connid)`

Fired when a connection object is allocated from the connection pool.

- `connid`: The connection ID

- `conn-release(connid)`

Fired when a connection object is released back to the connection pool.

Arguments:

- `connid`: The connection ID

- `conn-create(ptr)`

Fired when a new connection object is being created (that is, there are no free connection objects in the connection pool).

Arguments:

- `ptr`: A pointer to the connection object

- `conn-destroy(ptr)`

Fired when a connection object is being destroyed.

Arguments:

- `ptr`: A pointer to the connection object

- `conn-dispatch(connid, threadid)`

Fired when a connection is dispatched from the main or connection-management thread to a worker thread.

Arguments:

- `connid`: The connection ID

- `threadid`: The thread ID
- `slabs-allocate(size, slabclass, slabsize, ptr)`

Allocate memory from the slab allocator

Arguments:

- `size`: The requested size
- `slabclass`: The allocation is fulfilled in this class
- `slabsize`: The size of each item in this class
- `ptr`: A pointer to allocated memory
- `slabs-allocate-failed(size, slabclass)`

Failed to allocate memory (out of memory)

Arguments:

- `size`: The requested size
- `slabclass`: The class that failed to fulfill the request
- `slabs-slabclass-allocate(slabclass)`

Fired when a slab class needs more space

Arguments:

- `slabclass`: The class that needs more memory
- `slabs-slabclass-allocate-failed(slabclass)`

Failed to allocate memory (out of memory)

Arguments:

- `slabclass`: The class that failed to grab more memory
- `slabs-free(size, slabclass, ptr)`

Release memory

Arguments:

- `size`: The size of the memory
- `slabclass`: The class the memory belongs to
- `ptr`: A pointer to the memory to release
- `assoc-find(key, depth)`

Fired when the when we have searched the hash table for a named key. These two elements provide an insight in how well the hash function operates. Traversals are a sign of a less optimal function, wasting cpu capacity.

Arguments:

- `key`: The key searched for
- `depth`: The depth in the list of hash table
- `assoc-insert(key, nokeys)`

Fired when a new item has been inserted.

Arguments:

- `key`: The key just inserted
- `nokeys`: The total number of keys currently being stored, including the key for which insert was called.

- `assoc-delete(key, nokeys)`

Fired when a new item has been removed.

Arguments:

- `key`: The key just deleted
 - `nokeys`: The total number of keys currently being stored, excluding the key for which delete was called.
- `item-link(key, size)`

Fired when an item is being linked in the cache

Arguments:

- `key`: The items key
 - `size`: The size of the data
- `item-unlink(key, size)`

Fired when an item is being deleted

Arguments:

- `key`: The items key
 - `size`: The size of the data
- `item-remove(key, size)`

Fired when the refcount for an item is reduced

Arguments:

- `key`: The items key
 - `size`: The size of the data
- `item-update(key, size)`

Fired when the "last referenced" time is updated

Arguments:

- `key`: The items key
 - `size`: The size of the data
- `item-replace(oldkey, oldsize, newkey, newsize)`

Fired when an item is being replaced with another item

Arguments:

- `oldkey`: The key of the item to replace
 - `oldsize`: The size of the old item
 - `newkey`: The key of the new item
 - `newsize`: The size of the new item
- `process-command-start(connid, request, size)`

Fired when the processing of a command starts

Arguments:

- `connid`: The connection ID
- `request`: The incoming request
- `size`: The size of the request
- `process-command-end(connid, response, size)`

Fired when the processing of a command is done

Arguments:

- `connid`: The connection ID
- `response`: The response to send back to the client
- `size`: The size of the response
- `command-get(connid, key, size)`

Fired for a get-command

Arguments:

- `connid`: The connection ID
- `key`: The requested key
- `size`: The size of the key's data (or -1 if not found)
- `command-gets(connid, key, size, casid)`

Fired for a gets command

Arguments:

- `connid`: The connection ID
- `key`: The requested key
- `size`: The size of the key's data (or -1 if not found)
- `casid`: The casid for the item
- `command-add(connid, key, size)`

Fired for a add-command

Arguments:

- `connid`: The connection ID
- `key`: The requested key
- `size`: The new size of the key's data (or -1 if not found)
- `command-set(connid, key, size)`

Fired for a set-command

Arguments:

- `connid`: The connection ID
- `key`: The requested key
- `size`: The new size of the key's data (or -1 if not found)
- `command-replace(connid, key, size)`

Fired for a replace-command

Arguments:

- `connid`: The connection ID
- `key`: The requested key
- `size`: The new size of the key's data (or -1 if not found)
- `command-prepend(connid, key, size)`

Fired for a prepend-command

Arguments:

- `connid`: The connection ID
- `key`: The requested key
- `size`: The new size of the key's data (or -1 if not found)
- `command-append(connid, key, size)`

Fired for a append-command

Arguments:

- `connid`: The connection ID
- `key`: The requested key
- `size`: The new size of the key's data (or -1 if not found)
- `command-cas(connid, key, size, casid)`

Fired for a cas-command

Arguments:

- `connid`: The connection ID
- `key`: The requested key
- `size`: The size of the key's data (or -1 if not found)
- `casid`: The cas ID requested
- `command-incr(connid, key, val)`

Fired for incr command

Arguments:

- `connid`: The connection ID
- `key`: The requested key
- `val`: The new value
- `command-decr(connid, key, val)`

Fired for decr command

Arguments:

- `connid`: The connection ID
- `key`: The requested key
- `val`: The new value

- `command-delete(connid, key, exptime)`

Fired for a delete command

Arguments:

- `connid`: The connection ID
- `key`: The requested key
- `exptime`: The expiry time

4.2.6. Memory allocation within memcached

When you first start `memcached`, the memory that you have configured is not automatically allocated. Instead, `memcached` only starts allocating and reserving physical memory once you start saving information into the cache.

When you start to store data into the cache, `memcached` does not allocate the memory for the data on an item by item basis. Instead, a slab allocation is used to optimize memory usage and prevent memory fragmentation when information expires from the cache.

With slab allocation, memory is reserved in blocks of 1MB. The slab is divided up into a number of blocks of equal size. When you try to store a value into the cache, `memcached` checks the size of the value that you are adding to the cache and determines which slab contains the right size allocation for the item. If a slab with the item size already exists, the item is written to the block within the slab.

If the new item is bigger than the size of any existing blocks, then a new slab is created, divided up into blocks of a suitable size. If an existing slab with the right block size already exists, but there are no free blocks, a new slab is created. If you update an existing item with data that is larger than the existing block allocation for that key, then the key is re-allocated into a suitable slab.

For example, the default size for the smallest block is 88 bytes (40 bytes of value, and the default 48 bytes for the key and flag data). If the size of the first item you store into the cache is less than 40 bytes, then a slab with a block size of 88 bytes is created and the value stored.

If the size of the data that you want to store is larger than this value, then the block size is increased by the chunk size factor until a block size large enough to hold the value is determined. The block size is always a function of the scale factor, rounded up to a block size which is exactly divisible into the chunk size.

For a sample of the structure, see [Figure 4.4, “Memory Allocation in memcached”](#).

Figure 4.4. Memory Allocation in memcached

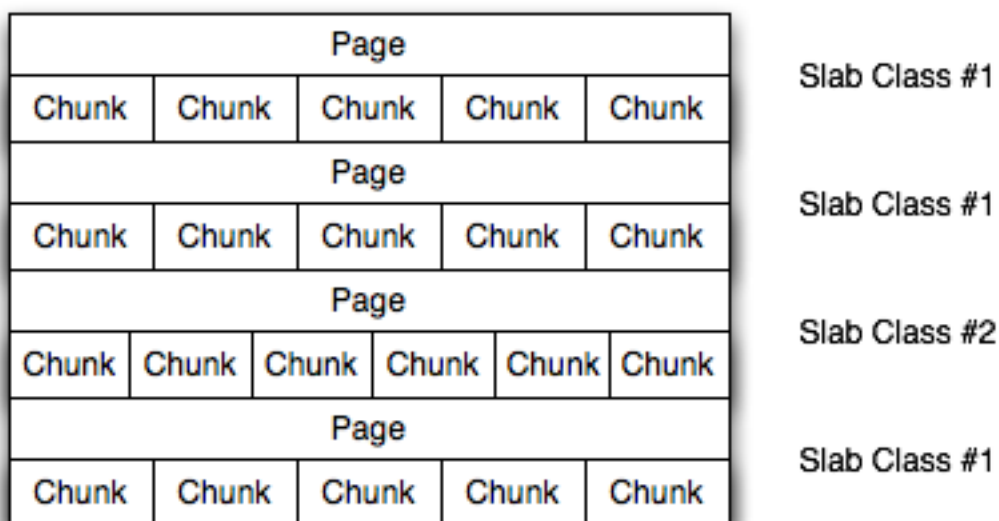

The result is that you have multiple pages allocated within the range of memory allocated to `memcached`. Each page is 1MB in

size (by default), and is split into a different number of chunks, according to the chunk size required to store the key/value pairs. Each instance has multiple pages allocated, and a page is always created when a new item needs to be created requiring a chunk of a particular size. A slab may consist of multiple pages, and each page within a slab contains an equal number of chunks.

The chunk size of a new slab is determined by the base chunk size combined with the chunk size growth factor. For example, if the initial chunks are 104 bytes in size, and the default chunk size growth factor is used (1.25), then the next chunk size allocated would be the best power of 2 fit for $104 * 1.25$, or 136 bytes.

Allocating the pages in this way ensures that memory does not get fragmented. However, depending on the distribution of the objects that you want to store, it may lead to an inefficient distribution of the slabs and chunks if you have significantly different sized items. For example, having a relatively small number of items within each chunk size may waste a lot of memory with just few chunks in each allocated page.

You can tune the growth factor to reduce this effect by using the `-f` command line option, which adapts the growth factor applied to make more effective use of the chunks and slabs allocated. For information on how to determine the current slab allocation statistics, see [Section 4.4.2, “memcached Slabs Statistics”](#).

If your operating system supports it, you can also start memcached with the `-L` command line option. This option preallocates all the memory during startup using large memory pages. This can improve performance by reducing the number of misses in the CPU memory cache.

4.2.7. memcached thread Support

If you enable the thread implementation within when building memcached from source, then memcached uses multiple threads in addition to the libevent system to handle requests.

When enabled, the threading implementation operates as follows:

- Threading is handled by wrapping functions within the code to provide basic protection from updating the same global structures at the same time.
- Each thread uses its own instance of the libevent to help improve performance.
- TCP/IP connections are handled with a single thread listening on the TCP/IP socket. Each connection is then distribution to one of the active threads on a simple round-robin basis. Each connection then operates solely within this thread while the connection remains open.
- For UDP connections, all the threads listen to a single UDP socket for incoming requests. Threads that are not currently dealing with another request ignore the incoming packet. One of the remaining, nonbusy, threads reads the request and sends the response. This implementation can lead to increased CPU load as threads wake from sleep to potentially process the request.

Using threads can increase the performance on servers that have multiple CPU cores available, as the requests to update the hash table can be spread between the individual threads. However, because of the locking mechanism employed you may want to experiment with different thread values to achieve the best performance based on the number and type of requests within your given workload.

4.2.8. memcached Logs

If you enable verbose mode, using the `-v`, `-vv`, or `-vvv` options, then the information output by memcached includes details of the operations being performed.

Without the verbose options, memcached normally produces no output during normal operating.

- **Output when using `-v`**

The lowest verbosity level shows you:

- Errors and warnings
- Transient errors
- Protocol and socket errors, including exhausting available connections
- Each registered client connection, including the socket descriptor number and the protocol used.

For example:

```
32: Client using the ascii protocol
33: Client using the ascii protocol
```

Note that the socket descriptor is only valid while the client remains connected. Non-persistent connections may not be effectively represented.

Examples of the error messages output at this level include:

```
<%d send buffer was %d, now %d
Can't listen for events on fd %d
Can't read from libevent pipe
Catastrophic: event fd doesn't match conn fd!
Couldn't build response
Couldn't realloc input buffer
Couldn't update event
Failed to build UDP headers
Failed to read, and not due to blocking
Too many open connections
Unexpected state %d
```

- **Output when using `-vv`**

When using the second level of verbosity, you get more detailed information about protocol operations, keys updated, chunk and network operations and details.

During the initial start-up of `memcached` with this level of verbosity, you are shown the sizes of the individual slab classes, the chunk sizes, and the number of entries per slab. These do not show the allocation of the slabs, just the slabs that would be created when data is added. You are also given information about the listen queues and buffers used to send information. A sample of the output generated for a TCP/IP based system with the default memory and growth factors is given below:

```
shell> memcached -vv
slab class 1: chunk size 80 perslab 13107
slab class 2: chunk size 104 perslab 10082
slab class 3: chunk size 136 perslab 7710
slab class 4: chunk size 176 perslab 5957
slab class 5: chunk size 224 perslab 4681
slab class 6: chunk size 280 perslab 3744
slab class 7: chunk size 352 perslab 2978
slab class 8: chunk size 440 perslab 2383
slab class 9: chunk size 552 perslab 1899
slab class 10: chunk size 696 perslab 1506
slab class 11: chunk size 872 perslab 1202
slab class 12: chunk size 1096 perslab 956
slab class 13: chunk size 1376 perslab 762
slab class 14: chunk size 1720 perslab 609
slab class 15: chunk size 2152 perslab 487
slab class 16: chunk size 2696 perslab 388
slab class 17: chunk size 3376 perslab 310
slab class 18: chunk size 4224 perslab 248
slab class 19: chunk size 5280 perslab 198
slab class 20: chunk size 6600 perslab 158
slab class 21: chunk size 8256 perslab 127
slab class 22: chunk size 10320 perslab 101
slab class 23: chunk size 12904 perslab 81
slab class 24: chunk size 16136 perslab 64
slab class 25: chunk size 20176 perslab 51
slab class 26: chunk size 25224 perslab 41
slab class 27: chunk size 31536 perslab 33
slab class 28: chunk size 39424 perslab 26
slab class 29: chunk size 49280 perslab 21
slab class 30: chunk size 61600 perslab 17
slab class 31: chunk size 77000 perslab 13
slab class 32: chunk size 96256 perslab 10
slab class 33: chunk size 120320 perslab 8
slab class 34: chunk size 150400 perslab 6
slab class 35: chunk size 188000 perslab 5
slab class 36: chunk size 235000 perslab 4
slab class 37: chunk size 293752 perslab 3
slab class 38: chunk size 367192 perslab 2
slab class 39: chunk size 458992 perslab 2
<26 server listening (auto-negotiate)
<29 server listening (auto-negotiate)
<30 send buffer was 57344, now 2097152
<31 send buffer was 57344, now 2097152
<30 server listening (udp)
<30 server listening (udp)
<31 server listening (udp)
<30 server listening (udp)
<30 server listening (udp)
<31 server listening (udp)
<31 server listening (udp)
<31 server listening (udp)
```

Using this verbosity level can be a useful way to check the effects of the growth factor used on slabs with different memory allocations, which in turn can be used to better tune the growth factor to suit the data you are storing in the cache. For example, if

you set the growth factor to 4 (quadrupling the size of each slab):

```
shell> memcached -f 4 -m lg -vv
slab class 1: chunk size 80 perslab 13107
slab class 2: chunk size 320 perslab 3276
slab class 3: chunk size 1280 perslab 819
slab class 4: chunk size 5120 perslab 204
slab class 5: chunk size 20480 perslab 51
slab class 6: chunk size 81920 perslab 12
slab class 7: chunk size 327680 perslab 3
...
```

During use of the cache, this verbosity level also prints out detailed information on the storage and recovery of keys and other information. An example of the output during a typical set/get and increment/decrement operation is shown below.

```
32: Client using the ascii protocol
<32 set my_key 0 0 10
>32 STORED
<32 set object_key 1 0 36
>32 STORED
<32 get my_key
>32 sending key my_key
>32 END
<32 get object_key
>32 sending key object_key
>32 END
<32 set key 0 0 6
>32 STORED
<32 incr key 1
>32 789544
<32 decr key 1
>32 789543
<32 incr key 2
>32 789545
<32 set my_key 0 0 10
>32 STORED
<32 set object_key 1 0 36
>32 STORED
<32 get my_key
>32 sending key my_key
>32 END
<32 get object_key
>32 sending key object_key1 1 36
>32 END
<32 set key 0 0 6
>32 STORED
<32 incr key 1
>32 789544
<32 decr key 1
>32 789543
<32 incr key 2
>32 789545
```

During client communication, for each line, the initial character shows the direction of flow of the information. The < for communication from the client to the memcached server and > for communication back to the client. The number is the numeric socket descriptor for the connection.

- **Output when using -vvv**

This level of verbosity includes the transitions of connections between different states in the event library while reading and writing content to/from the clients. It should be used to diagnose and identify issues in client communication. For example, you can use this information to determine if memcached is taking a long time to return information to the client, during the read of the client operation or before returning and completing the operation. An example of the typical sequence for a set operation is provided below:

```
<32 new auto-negotiating client connection
32: going from conn_new_cmd to conn_waiting
32: going from conn_waiting to conn_read
32: going from conn_read to conn_parse_cmd
32: Client using the ascii protocol
<32 set my_key 0 0 10
32: going from conn_parse_cmd to conn_nread
> NOT FOUND my_key
>32 STORED
32: going from conn_nread to conn_write
32: going from conn_write to conn_new_cmd
32: going from conn_new_cmd to conn_waiting
32: going from conn_waiting to conn_read
32: going from conn_read to conn_closing
<32 connection closed.
```

All of the verbosity levels in memcached are designed to be used during debugging or examination of issues. The quantity of information generated, particularly when using -vvv, is significant, particularly on a busy server. Also be aware that writing the er-

ror information out, especially to disk, may negate some of the performance gains you achieve by using `memcached`. Therefore, use in production or deployment environments is not recommended.

4.3. `memcached` Interfaces

A number of interfaces from different languages exist for interacting with `memcached` servers and storing and retrieving information. Interfaces for the most common language platforms including Perl, PHP, Python, Ruby, C and Java.

Data stored into a `memcached` server is referred to by a single string (the key), with storage into the cache and retrieval from the cache using the key as the reference. The cache therefore operates like a large associative array or hash. It is not possible to structure or otherwise organize the information stored in the cache. If you want to store information in a structured way, you must use 'formatted' keys.

The following tips may be useful to you when using `memcached`:

The general sequence for using `memcached` in any language as a caching solution is as follows:

1. Request the item from the cache.
2. If the item exists, use the item data.
3. If the item does not exist, load the data from MySQL, and store the value into the cache. This means the value is available to the next client that requests it from the cache.

For a flow diagram of this sequence, see [Figure 4.5, “Typical `memcached` Application Flowchart”](#).

Figure 4.5. Typical `memcached` Application Flowchart

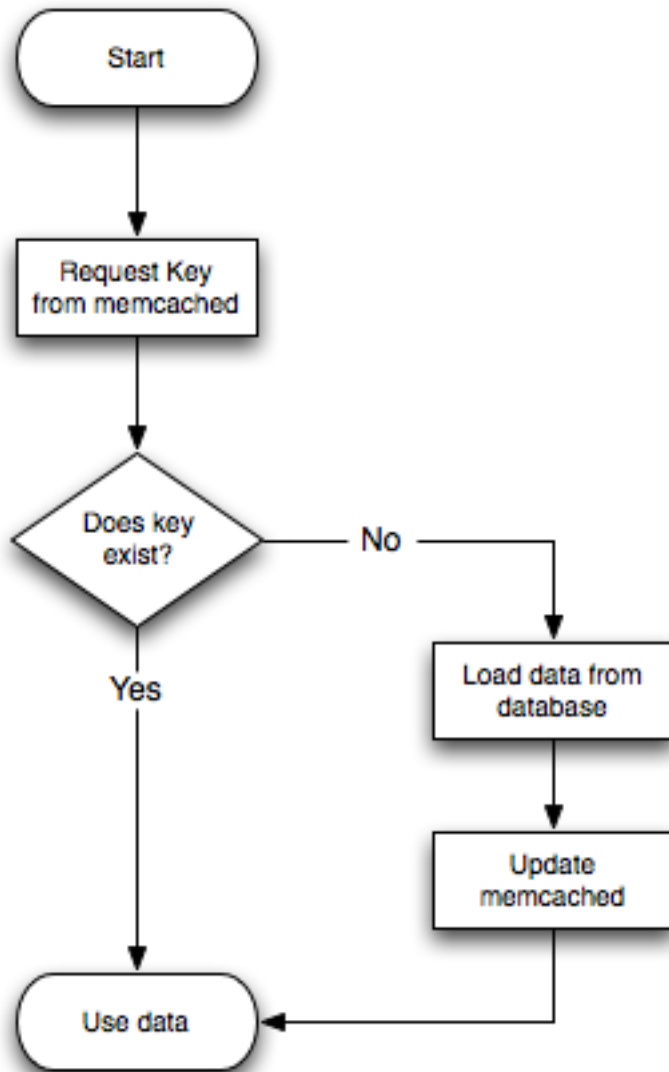

The interface to `memcached` supports the following methods for storing and retrieving information in the cache, and these are consistent across all the different APIs, even though the language specific mechanics may be different:

- `get(key)`: Retrieves information from the cache. Returns the value if it exists, or `NULL`, `nil`, or `undefined` or the closest equivalent in the corresponding language, if the specified key does not exist.
- `set(key, value [, expiry])`: Sets the key in the cache to the specified value. Note that this either updates an existing key if it already exists, or adds a new key/value pair if the key doesn't exist. If the expiry time is specified, then the key expires (and is deleted) when the expiry time is reached. The time is specified in seconds, and is taken as a relative time if the value is less than 30 days ($30*24*60*60$), or an absolute time (epoch) if larger than this value.
- `add(key, value [, expiry])`: Adds the key to the cache, if the specified key doesn't already exist.
- `replace(key, value [, expiry])`: Replaces the `value` of the specified `key`, only if the key already exists.
- `delete(key [, time])`: Deletes the `key` from the cache. If you supply a `time`, then adding a value with the specified `key` is blocked for the specified period.
- `incr(key [, value])`: Increments the specified `key` by one or the specified `value`.
- `decr(key [, value])`: Decrements the specified `key` by one or the specified `value`.
- `flush_all`: Invalidates (or expires) all the current items in the cache. Technically they still exist (they are not deleted), but they are silently destroyed the next time you try to access them.

In all implementations, most or all of these functions are duplicated through the corresponding native language interface.

For all languages and interfaces, use `memcached` to store full items, rather than simply caching single rows of information from the database. For example, when displaying a record about an object (invoice, user history, or blog post), load all the data for the associated entry from the database, and compile it into the internal structure that would normally be required by the application. You then save the complete object into the cache.

Complex data structures cannot be stored directly. Most interfaces serialize the data for you, that is, put it in a form that can reconstruct the original pointers and nesting. Perl uses `Storable`, PHP uses `serialize`, Python uses `cPickle` (or `Pickle`) and Java uses the `Serializable` interface. In most cases, the serialization interface used is customizable. To share data stored in `memcached` instances between different language interfaces, consider using a common serialization solution such as JSON (Javascript Object Notation).

4.3.1. Using `libmemcached`

The `libmemcached` library provides both C and C++ interfaces to `memcached` and is also the basis for a number of different additional API implementations, including Perl, Python and Ruby. Understanding the core `libmemcached` functions can help when using these other interfaces.

The C library is the most comprehensive interface library for `memcached` and provides a wealth of functions and operational systems not always exposed in the other interfaces not based on the `libmemcached` library.

The different functions can be divided up according to their basic operation. In addition to functions that interface to the core API, there are a number of utility functions that provide extended functionality, such as appending and prepending data.

To build and install `libmemcached`, download the `libmemcached` package, run configure, and then build and install:

```
shell> tar xjf libmemcached-0.21.tar.gz
shell> cd libmemcached-0.21
shell> ./configure
shell> make
shell> make install
```

On many Linux operating systems, you can install the corresponding `libmemcached` package through the usual `yum`, `apt-get` or similar commands.

To build an application that uses the library, you need to first set the list of servers. You can do this either by directly manipulating the servers configured within the main `memcached_st` structure, or by separately populating a list of servers, and then adding this list to the `memcached_st` structure. The latter method is used in the following example. Once the server list has been set, you can call the functions to store or retrieve data. A simple application for setting a preset value to localhost is provided here:

```
#include <stdio.h>
#include <string.h>
#include <unistd.h>
#include <libmemcached/memcached.h>
int main(int argc, char *argv[])
{
    memcached_server_st *servers = NULL;
    memcached_st *memc;
    memcached_return rc;
    char *key= "keystring";
    char *value= "keyvalue";
    memcached_server_st *memcached_servers_parse (char *server_strings);
    memc= memcached_create(NULL);
    servers= memcached_server_list_append(servers, "localhost", 11211, &rc);
    rc= memcached_server_push(memc, servers);
    if (rc == MEMCACHED_SUCCESS)
        fprintf(stderr,"Added server successfully\n");
    else
        fprintf(stderr,"Couldn't add server: %s\n",memcached_strerror(memc, rc));
    rc= memcached_set(memc, key, strlen(key), value, strlen(value), (time_t)0, (uint32_t)0);
    if (rc == MEMCACHED_SUCCESS)
        fprintf(stderr,"Key stored successfully\n");
    else
        fprintf(stderr,"Couldn't store key: %s\n",memcached_strerror(memc, rc));
    return 0;
}
```

You can test the success of an operation by using the return value, or populated result code, for a given function. The value is always set to `MEMCACHED_SUCCESS` if the operation succeeded. In the event of a failure, use the `memcached_strerror()` function to translate the result code into a printable string.

To build the application, you must specify the `memcached` library:

```
shell> gcc -o memc_basic memc_basic.c -lmemcached
```

Running the above sample application, after starting a `memcached` server, should return a success message:

```
shell> memc_basic
Added server successfully
Key stored successfully
```

4.3.1.1. libmemcached Base Functions

The base `libmemcached` functions enable you to create, destroy and clone the main `memcached_st` structure that is used to interface to the `memcached` servers. The main functions are defined below:

```
memcached_st *memcached_create (memcached_st *ptr);
```

Creates a new `memcached_st` structure for use with the other `libmemcached` API functions. You can supply an existing, static, `memcached_st` structure, or `NULL` to have a new structured allocated. Returns a pointer to the created structure, or `NULL` on failure.

```
void memcached_free (memcached_st *ptr);
```

Free the structure and memory allocated to a previously created `memcached_st` structure.

```
memcached_st *memcached_clone(memcached_st *clone, memcached_st *source);
```

Clone an existing `memcached` structure from the specified `source`, copying the defaults and list of servers defined in the structure.

4.3.1.2. libmemcached Server Functions

The `libmemcached` API uses a list of servers, stored within the `memcached_server_st` structure, to act as the list of servers used by the rest of the functions. To use `memcached`, you first create the server list, and then apply the list of servers to a valid `libmemcached` object.

Because the list of servers, and the list of servers within an active `libmemcached` object can be manipulated separately, you can update and manage server lists while an active `libmemcached` interface is running.

The functions for manipulating the list of servers within a `memcached_st` structure are given below:

```
memcached_return
memcached_server_add (memcached_st *ptr,
                     char *hostname,
                     unsigned int port);
```

Add a server, using the given `hostname` and `port` into the `memcached_st` structure given in `ptr`.

```
memcached_return
memcached_server_add_unix_socket (memcached_st *ptr,
                                 char *socket);
```

Add a Unix socket to the list of servers configured in the `memcached_st` structure.

```
unsigned int memcached_server_count (memcached_st *ptr);
```

Return a count of the number of configured servers within the `memcached_st` structure.

```
memcached_server_st *
memcached_server_list (memcached_st *ptr);
```

Returns an array of all the defined hosts within a `memcached_st` structure.

```
memcached_return
memcached_server_push (memcached_st *ptr,
                      memcached_server_st *list);
```

Pushes an existing list of servers onto list of servers configured for a current `memcached_st` structure. This adds servers to the end of the existing list, and duplicates are not checked.

The `memcached_server_st` structure can be used to create a list of `memcached` servers which can then be applied individually to `memcached_st` structures.

```
memcached_server_st *
memcached_server_list_append (memcached_server_st *ptr,
                              char *hostname,
```

```
unsigned int port,
memcached_return *error);
```

Add a server, with `hostname` and `port`, to the server list in `ptr`. The result code is handled by the `error` argument, which should point to an existing `memcached_return` variable. The function returns a pointer to the returned list.

```
unsigned int memcached_server_list_count (memcached_server_st *ptr);
```

Return the number of the servers in the server list.

```
void memcached_server_list_free (memcached_server_st *ptr);
```

Free up the memory associated with a server list.

```
memcached_server_st *memcached_servers_parse (char *server_strings);
```

Parses a string containing a list of servers, where individual servers are separated by a comma, space, or both, and where individual servers are of the form `server[:port]`. The return value is a server list structure.

4.3.1.3. libmemcached Set Functions

The set related functions within `libmemcached` provide the same functionality as the core functions supported by the `memcached` protocol. The full definition for the different functions is the same for all the base functions (add, replace, prepend, append). For example, the function definition for `memcached_set()` is:

```
memcached_return
memcached_set (memcached_st *ptr,
              const char *key,
              size_t key_length,
              const char *value,
              size_t value_length,
              time_t expiration,
              uint32_t flags);
```

The `ptr` is the `memcached_st` structure. The `key` and `key_length` define the key name and length, and `value` and `value_length` the corresponding value and length. You can also set the expiration and optional flags. For more information, see [Section 4.3.1.5, “libmemcached Behaviors”](#).

The following table outlines the remainder of the set-related functions.

libmemcached Function	Equivalent to
<code>memcached_set(memc, key, key_length, value, value_length, expiration, flags)</code>	Generic <code>set()</code> operation.
<code>memcached_add(memc, key, key_length, value, value_length, expiration, flags)</code>	Generic <code>add()</code> function.
<code>memcached_replace(memc, key, key_length, value, value_length, expiration, flags)</code>	Generic <code>replace()</code> .
<code>memcached_prepend(memc, key, key_length, value, value_length, expiration, flags)</code>	Prepends the specified <code>value</code> before the current value of the specified <code>key</code> .
<code>memcached_append(memc, key, key_length, value, value_length, expiration, flags)</code>	Appends the specified <code>value</code> after the current value of the specified <code>key</code> .
<code>memcached_cas(memc, key, key_length, value, value_length, expiration, flags, cas)</code>	Overwrites the data for a given key as long as the corresponding <code>cas</code> value is still the same within the server.
<code>memcached_set_by_key(memc, master_key, master_key_length, key, key_length, value, value_length, expiration, flags)</code>	Similar to the generic <code>set()</code> , but has the option of an additional master key that can be used to identify an individual server.
<code>memcached_add_by_key(memc, master_key, master_key_length, key, key_length, value, value_length, expiration, flags)</code>	Similar to the generic <code>add()</code> , but has the option of an additional master key that can be used to identify an individual server.
<code>memcached_replace_by_key(memc, master_key, master_key_length, key, key_length, value, value_length, expiration, flags)</code>	Similar to the generic <code>replace()</code> , but has the option of an additional master key that can be used to identify an individual server.
<code>memcached_prepend_by_key(memc, master_key, master_key_length, key, key_length, value, value_length, expiration, flags)</code>	Similar to the <code>memcached_prepend()</code> , but has the option of an additional master key that can be used to identify an individual server.

libmemcached Function	Equivalent to
<code>memcached_append_by_key(memc, master_key, master_key_length, key, key_length, value, value_length, expiration, flags)</code>	Similar to the <code>memcached_append()</code> , but has the option of an additional master key that can be used to identify an individual server.
<code>memcached_cas_by_key(memc, master_key, master_key_length, key, key_length, value, value_length, expiration, flags)</code>	Similar to the <code>memcached_cas()</code> , but has the option of an additional master key that can be used to identify an individual server.

The `by_key` methods add two further arguments, the master key, to be used and applied during the hashing stage for selecting the servers. You can see this in the following definition:

```
memcached_return
memcached_set_by_key(memcached_st *ptr,
                    const char *master_key,
                    size_t master_key_length,
                    const char *key,
                    size_t key_length,
                    const char *value,
                    size_t value_length,
                    time_t expiration,
                    uint32_t flags);
```

All the functions return a value of type `memcached_return`, which you can compare against the `MEMCACHED_SUCCESS` constant.

4.3.1.4. libmemcached Get Functions

The `libmemcached` functions provide both direct access to a single item, and a multiple-key request mechanism that provides much faster responses when fetching a large number of keys simultaneously.

The main get-style function, which is equivalent to the generic `get()` is `memcached_get()`. The function returns a string pointer to the returned value for a corresponding key.

```
char *memcached_get (memcached_st *ptr,
                   const char *key, size_t key_length,
                   size_t *value_length,
                   uint32_t *flags,
                   memcached_return *error);
```

A multi-key get, `memcached_mget()`, is also available. Using a multiple key get operation is much quicker to do in one block than retrieving the key values with individual calls to `memcached_get()`. To start the multi-key get, you need to call `memcached_mget()`:

```
memcached_return
memcached_mget (memcached_st *ptr,
               char **keys, size_t *key_length,
               unsigned int number_of_keys);
```

The return value is the success of the operation. The `keys` parameter should be an array of strings containing the keys, and `key_length` an array containing the length of each corresponding key. `number_of_keys` is the number of keys supplied in the array.

To fetch the individual values, you need to use `memcached_fetch()` to get each corresponding value.

```
char *memcached_fetch (memcached_st *ptr,
                     const char *key, size_t *key_length,
                     size_t *value_length,
                     uint32_t *flags,
                     memcached_return *error);
```

The function returns the key value, with the `key`, `key_length` and `value_length` parameters being populated with the corresponding key and length information. The function returns `NULL` when there are no more values to be returned. A full example, including the populating of the key data and the return of the information is provided here.

```
#include <stdio.h>
#include <sstring.h>
#include <unistd.h>
#include <libmemcached/memcached.h>
int main(int argc, char *argv[])
{
    memcached_server_st *servers = NULL;
    memcached_st *memc;
    memcached_return rc;
    char *keys[] = {"huey", "dewey", "louie"};
    size_t key_length[3];
```



```

char *values[]= {"red", "blue", "green"};
size_t value_length[3];
unsigned int x;
uint32_t flags;
char return_key[MEMCACHED_MAX_KEY];
size_t return_key_length;
char *return_value;
size_t return_value_length;
memc= memcached_create(NULL);
servers= memcached_server_list_append(servers, "localhost", 11211, &rc);
rc= memcached_server_push(memc, servers);
if (rc == MEMCACHED_SUCCESS)
    fprintf(stderr, "Added server successfully\n");
else
    fprintf(stderr, "Couldn't add server: %s\n", memcached_strerror(memc, rc));
for(x= 0; x < 3; x++)
    {
        key_length[x] = strlen(keys[x]);
        value_length[x] = strlen(values[x]);
        rc= memcached_set(memc, keys[x], key_length[x], values[x],
            value_length[x], (time_t)0, (uint32_t)0);
        if (rc == MEMCACHED_SUCCESS)
            fprintf(stderr, "Key %s stored successfully\n", keys[x]);
        else
            fprintf(stderr, "Couldn't store key: %s\n", memcached_strerror(memc, rc));
    }
rc= memcached_mget(memc, keys, key_length, 3);
if (rc == MEMCACHED_SUCCESS)
    {
        while ((return_value= memcached_fetch(memc, return_key, &return_key_length,
            &return_value_length, &flags, &rc)) != NULL)
            {
                if (rc == MEMCACHED_SUCCESS)
                    {
                        fprintf(stderr, "Key %s returned %s\n", return_key, return_value);
                    }
            }
    }
return 0;
}

```

Running the above application:

```

shell> memc_multi_fetch
Added server successfully
Key huey stored successfully
Key dewey stored successfully
Key louie stored successfully
Key huey returned red
Key dewey returned blue
Key louie returned green

```

4.3.1.5. libmemcached Behaviors

The behavior of `libmemcached` can be modified by setting one or more behavior flags. These can either be set globally, or they can be applied during the call to individual functions. Some behaviors also accept an additional setting, such as the hashing mechanism used when selecting servers.

To set global behaviors:

```

memcached_return
    memcached_behavior_set (memcached_st *ptr,
        memcached_behavior flag,
        uint64_t data);

```

To get the current behavior setting:

```

uint64_t
    memcached_behavior_get (memcached_st *ptr,
        memcached_behavior flag);

```

Behavior	Description
<code>MEMCACHED_BEHAVIOR_NO_BLOCK</code>	Caused <code>libmemcached</code> to use asynchronous I/O.
<code>MEMCACHED_BEHAVIOR_TCP_NODELAY</code>	Turns on no-delay for network sockets.
<code>MEMCACHED_BEHAVIOR_HASH</code>	Without a value, sets the default hashing algorithm for keys to use MD5. Other valid values include <code>MEMCACHED_HASH_DEFAULT</code> , <code>MEMCACHED_HASH_MD5</code> , <code>MEMCACHED_HASH_CRC</code> , <code>MEMCACHED_HASH_FNV1_64</code> , <code>MEMCACHED_HASH_FNV1A_64</code> , <code>MEMCACHED_HASH_FNV1_32</code> , and <code>MEMCACHED_HASH_FNV1A_32</code> .
<code>MEMCACHED_BEHAVIOR_DISTRIBUTION</code>	Changes the method of selecting the server used to store a given value. The

Behavior	Description
	default method is <code>MEMCACHED_DISTRIBUTION_MODULA</code> . You can enable consistent hashing by setting <code>MEMCACHED_DISTRIBUTION_CONSISTENT</code> . <code>MEMCACHED_DISTRIBUTION_CONSISTENT</code> is an alias for the value <code>MEMCACHED_DISTRIBUTION_CONSISTENT_KETAMA</code> .
<code>MEMCACHED_BEHAVIOR_CACHE_LOOKUPS</code>	Cache the lookups made to the DNS service. This can improve the performance if you are using names instead of IP addresses for individual hosts.
<code>MEMCACHED_BEHAVIOR_SUPPORT_CAS</code>	Support CAS operations. By default, this is disabled because it imposes a performance penalty.
<code>MEMCACHED_BEHAVIOR_KETAMA</code>	Sets the default distribution to <code>MEMCACHED_DISTRIBUTION_CONSISTENT_KETAMA</code> and the hash to <code>MEMCACHED_HASH_MD5</code> .
<code>MEMCACHED_BEHAVIOR_POLL_TIMEOUT</code>	Modify the timeout value used by <code>poll()</code> . Supply a <code>signed int</code> pointer for the timeout value.
<code>MEMCACHED_BEHAVIOR_BUFFER_REQUESTS</code>	Buffers IO requests instead of them being sent. A get operation, or closing the connection causes the data to be flushed.
<code>MEMCACHED_BEHAVIOR_VERIFY_KEY</code>	Forces <code>libmemcached</code> to verify that a specified key is valid.
<code>MEMCACHED_BEHAVIOR_SORT_HOSTS</code>	If set, hosts added to the list of configured hosts for a <code>memcached_st</code> structure are placed into the host list in sorted order. This breaks consistent hashing if that behavior has been enabled.
<code>MEMCACHED_BEHAVIOR_CONNECT_TIMEOUT</code>	In nonblocking mode this changes the value of the timeout during socket connection.

4.3.1.6. libmemcached Command-line Utilities

In addition to the main C library interface, `libmemcached` also includes a number of command line utilities that can be useful when working with and debugging `memcached` applications.

All of the command line tools accept a number of arguments, the most critical of which is `servers`, which specifies the list of servers to connect to when returning information.

The main tools are:

- `memcat`: Display the value for each ID given on the command line:

```
shell> memcat --servers=localhost hwkey
Hello world
```

- `memcp`: Copy the contents of a file into the cache, using the file names as the key:

```
shell> echo "Hello World" > hwkey
shell> memcp --servers=localhost hwkey
shell> memcat --servers=localhost hwkey
Hello world
```

- `memrm`: Remove an item from the cache:

```
shell> memcat --servers=localhost hwkey
Hello world
shell> memrm --servers=localhost hwkey
shell> memcat --servers=localhost hwkey
```

- `memslap`: Test the load on one or more `memcached` servers, simulating get/set and multiple client operations. For example, you can simulate the load of 100 clients performing get operations:

```
shell> memslap --servers=localhost --concurrency=100 --flush --test=get
memslap --servers=localhost --concurrency=100 --flush --test=get Threads connecting to servers 100
Took 13.571 seconds to read data
```

- `memflush`: Flush (empty) the contents of the `memcached` cache.

```
shell> memflush --servers=localhost
```

4.3.2. Using MySQL and memcached with Perl

The `Cache::Memcached` module provides a native interface to the Memcache protocol, and provides support for the core functions offered by `memcached`. You should install the module using your hosts native package management system. Alternatively, you can install the module using CPAN:

```
root-shell> perl -MCPAN -e 'install Cache::Memcached'
```

To use `memcached` from Perl through `Cache::Memcached` module, you first need to create a new `Cache::Memcached` object that defines the list of servers and other parameters for the connection. The only argument is a hash containing the options for the cache interface. For example, to create a new instance that uses three `memcached` servers:

```
use Cache::Memcached;
my $cache = new Cache::Memcached {
    'servers' => [
        '192.168.0.100:11211',
        '192.168.0.101:11211',
        '192.168.0.102:11211',
    ],
};
```

Note

When using the `Cache::Memcached` interface with multiple servers, the API automatically performs certain operations across all the servers in the group. For example, getting statistical information through `Cache::Memcached` returns a hash that contains data on a host by host basis, as well as generalized statistics for all the servers in the group.

You can set additional properties on the cache object instance when it is created by specifying the option as part of the option hash. Alternatively, you can use a corresponding method on the instance:

- `servers` or method `set_servers()`: Specifies the list of the servers to be used. The servers list should be a reference to an array of servers, with each element as the address and port number combination (separated by a colon). You can also specify a local connection through a UNIX socket (for example `/tmp/sock/memcached`). You can also specify the server with a weight (indicating how much more frequently the server should be used during hashing) by specifying an array reference with the `memcached` server instance and a weight number. Higher numbers give higher priority.
- `compress_threshold` or method `set_compress_threshold()`: Specifies the threshold when values are compressed. Values larger than the specified number are automatically compressed (using `zlib`) during storage and retrieval.
- `no_rehash` or method `set_norehash()`: Disables finding a new server if the original choice is unavailable.
- `readonly` or method `set_readonly()`: Disables writes to the `memcached` servers.

Once the `Cache::Memcached` object instance has been configured you can use the `set()` and `get()` methods to store and retrieve information from the `memcached` servers. Objects stored in the cache are automatically serialized and deserialized using the `Storable` module.

The `Cache::Memcached` interface supports the following methods for storing/retrieving data, and relate to the generic methods as shown in the table.

Cache::Memcached Function	Equivalent to
<code>get()</code>	Generic <code>get()</code>
<code>get_multi(keys)</code>	Gets multiple <code>keys</code> from memcache using just one query. Returns a hash reference of key/value pairs.
<code>set()</code>	Generic <code>set()</code>
<code>add()</code>	Generic <code>add()</code>
<code>replace()</code>	Generic <code>replace()</code>
<code>delete()</code>	Generic <code>delete()</code>
<code>incr()</code>	Generic <code>incr()</code>
<code>decr()</code>	Generic <code>decr()</code>

Below is a complete example for using `memcached` with Perl and the `Cache::Memcached` module:

```
#!/usr/bin/perl
use Cache::Memcached;
```

```

use DBI;
use Data::Dumper;
# Configure the memcached server
my $cache = new Cache::Memcached {
    'servers' => [
        'localhost:11211',
    ],
};
# Get the film name from the command line
# memcached keys must not contain spaces, so create
# a key name by replacing spaces with underscores
my $filname = shift or die "Must specify the film name\n";
my $filmkey = $filname;
$filmkey =~ s/ /_/;
# Load the data from the cache
my $filmdata = $cache->get($filmkey);
# If the data wasn't in the cache, then we load it from the database
if (!defined($filmdata))
{
    $filmdata = load_filmdata($filname);
    if (defined($filmdata))
    {
# Set the data into the cache, using the key
        if ($cache->set($filmkey,$filmdata))
        {
            print STDERR "Film data loaded from database and cached\n";
        }
        else
        {
            print STDERR "Couldn't store to cache\n";
        }
    }
    else
    {
        die "Couldn't find $filname\n";
    }
}
else
{
    print STDERR "Film data loaded from Memcached\n";
}
sub load_filmdata
{
    my ($filname) = @_ ;
    my $dsn = "DBI:mysql:database=sakila;host=localhost;port=3306";
    $dbh = DBI->connect($dsn,'sakila','password');
    my ($filmbase) = $dbh->selectrow_hashref(sprintf('select * from film where title = %s',
                                                    $dbh->quote($filname)));

    if (!defined($filmbase))
    {
        return (undef);
    }
    $filmbase->{stars} =
        $dbh->selectall_arrayref(sprintf('select concat(first_name," ",last_name) ' .
                                        'from film_actor left join (actor) ' .
                                        'on (film_actor.actor_id = actor.actor_id) ' .
                                        'where film_id=%s',
                                        $dbh->quote($filmbase->{film_id})));

    return($filmbase);
}

```

The example uses the Sakila database, obtaining film data from the database and writing a composite record of the film and actors to memcache. When calling it for a film does not exist, you get this result:

```

shell> memcached-sakila.pl "ROCK INSTINCT"
Film data loaded from database and cached

```

When accessing a film that has already been added to the cache:

```

shell> memcached-sakila.pl "ROCK INSTINCT"
Film data loaded from Memcached

```

4.3.3. Using MySQL and memcached with Python

The Python `memcache` module interfaces to `memcached` servers, and is written in pure python (that is, without using one of the C APIs). You can download and install a copy from [Python Memcached](#).

To install, download the package and then run the Python installer:

```

python setup.py install
running install
running bdist_egg
running egg_info
creating python_memcached.egg-info
...
removing 'build/bdist.linux-x86_64/egg' (and everything under it)
Processing python_memcached-1.43-py2.4.egg
creating /usr/lib64/python2.4/site-packages/python_memcached-1.43-py2.4.egg

```

```
Extracting python_memcached-1.43-py2.4.egg to /usr/lib64/python2.4/site-packages
Adding python-memcached 1.43 to easy-install.pth file
Installed /usr/lib64/python2.4/site-packages/python_memcached-1.43-py2.4.egg
Processing dependencies for python-memcached==1.43
Finished processing dependencies for python-memcached==1.43
```

Once installed, the `memcache` module provides a class-based interface to your `memcached` servers. Serialization of Python structures is handled by using the Python `cPickle` or `pickle` modules.

To create a new `memcache` interface, import the `memcache` module and create a new instance of the `memcache.Client` class:

```
import memcache
memc = memcache.Client(['127.0.0.1:11211'])
```

The first argument should be an array of strings containing the server and port number for each `memcached` instance you want to use. You can enable debugging by setting the optional `debug` parameter to 1.

By default, the hashing mechanism used is `crc32`. This provides a basic module hashing algorithm for selecting among multiple servers. You can change the function used by setting the value of `memcache.serverHashFunction` to the alternate function you want to use. For example:

```
from zlib import adler32
memcache.serverHashFunction = adler32
```

Once you have defined the servers to use within the `memcache` instance, the core functions provide the same functionality as in the generic interface specification. A summary of the supported functions is provided in the following table.

Python <code>memcache</code> Function	Equivalent to
<code>get()</code>	Generic <code>get()</code>
<code>get_multi(keys)</code>	Gets multiple values from the supplied array of <code>keys</code> . Returns a hash reference of key/value pairs.
<code>set()</code>	Generic <code>set()</code>
<code>set_multi(dict [, expiry [, key_prefix]])</code>	Sets multiple key/value pairs from the supplied <code>dict</code> .
<code>add()</code>	Generic <code>add()</code>
<code>replace()</code>	Generic <code>replace()</code>
<code>prepend(key, value [, expiry])</code>	Prepends the supplied <code>value</code> to the value of the existing <code>key</code> .
<code>append(key, value [, expiry])</code>	Appends the supplied <code>value</code> to the value of the existing <code>key</code> .
<code>delete()</code>	Generic <code>delete()</code>
<code>delete_multi(keys [, expiry [, key_prefix]])</code>	Deletes all the keys from the hash matching each string in the array <code>keys</code> .
<code>incr()</code>	Generic <code>incr()</code>
<code>decr()</code>	Generic <code>decr()</code>

Note

Within the Python `memcache` module, all the `*_multi()` functions support an optional `key_prefix` parameter. If supplied, then the string is used as a prefix to all key lookups. For example, if you call:

```
memc.get_multi(['a', 'b'], key_prefix='users:')
```

The function retrieves the keys `users:a` and `users:b` from the servers.

An example showing the storage and retrieval of information to a `memcache` instance, loading the raw data from MySQL, is shown below:

```
import sys
import MySQLdb
import memcache
memc = memcache.Client(['127.0.0.1:11211'], debug=1);
try:
    conn = MySQLdb.connect (host = "localhost",
                           user = "sakila",
                           passwd = "password",
                           db = "sakila")
except MySQLdb.Error, e:
    print "Error %d: %s" % (e.args[0], e.args[1])
```

```

    sys.exit (1)
popularfilms = memc.get('top5films')
if not popularfilms:
    cursor = conn.cursor()
    cursor.execute('select film_id,title from film order by rental_rate desc limit 5')
    rows = cursor.fetchall()
    memc.set('top5films',rows,60)
    print "Updated memcached with MySQL data"
else:
    print "Loaded data from memcached"
    for row in popularfilms:
        print "%s, %s" % (row[0], row[1])

```

When executed for the first time, the data is loaded from the MySQL database and stored to the `memcached` server.

```

shell> python memc_python.py
Updated memcached with MySQL data

```

The data is automatically serialized using `cPickle/pickle`. This means when you load the data back from `memcached`, you can use the object directly. In the example above, the information stored to `memcached` is in the form of rows from a Python DB cursor. When accessing the information (within the 60 second expiry time), the data is loaded from `memcached` and dumped:

```

shell> python memc_python.py
Loaded data from memcached
2, ACE GOLDFINGER
7, AIRPLANE SIERRA
8, AIRPORT POLLOCK
10, ALADDIN CALENDAR
13, ALI FOREVER

```

The serialization and deserialization happens automatically, but be aware that serialization of Python data may be incompatible with other interfaces and languages. You can change the serialization module used during initialization, for example to use JSON, which is more easily exchanged.

4.3.4. Using MySQL and memcached with PHP

PHP provides support for the Memcache functions through a PECL extension. To enable the PHP `memcache` extensions, you must build PHP using the `--enable-memcache` option to `configure` when building from source.

If you are installing on a RedHat based server, you can install the `php-pecl-memcache` RPM:

```

root-shell> yum --install php-pecl-memcache

```

On Debian based distributions, use the `php-memcache` package.

You can set global runtime configuration options by specifying the values in the following table within your `php.ini` file.

Configuration option	Default	Description
<code>memcache.allow_failover</code>	1	Specifies whether another server in the list should be queried if the first server selected fails.
<code>memcache.max_failover_attempts</code>	20	Specifies the number of servers to try before returning a failure.
<code>memcache.chunk_size</code>	8192	Defines the size of network chunks used to exchange data with the <code>memcached</code> server.
<code>memcache.default_port</code>	11211	Defines the default port to use when communicating with the <code>memcached</code> servers.
<code>memcache.hash_strategy</code>	standard	Specifies which hash strategy to use. Set to <code>consistent</code> to enable servers to be added or removed from the pool without causing the keys to be remapped to other servers. When set to <code>standard</code> , an older (modula) strategy is used that potentially uses different servers for storage.
<code>memcache.hash_function</code>	crc32	Specifies which function to use when mapping keys to servers. <code>crc32</code> uses the standard CRC32 hash. <code>fnv</code> uses the FNV-1a hashing algorithm.

To create a connection to a `memcached` server, you need to create a new `Memcache` object and then specifying the connection options. For example:

```

    }
  }
  else
  {
    $con = new mysqli('localhost','sakila','password','sakila') or
    die("<h1>Database problem</h1>" . mysqli_connect_error());
    $result = $con->query(sprintf('select * from film where title = "%s"', $_REQUEST['film']));
    $row = $result->fetch_array(MYSQLI_ASSOC);
    $memc->set($row['title'], $row);
    printf("<p>Loaded %s from MySQL</p>", $row['title']);
  }
?>

```

With PHP, the connections to the `memcached` instances are kept open as long as the PHP and associated Apache instance remain running. When adding or removing servers from the list in a running instance (for example, when starting another script that mentions additional servers), the connections are shared, but the script only selects among the instances explicitly configured within the script.

To ensure that changes to the server list within a script do not cause problems, make sure to use the consistent hashing mechanism.

4.3.5. Using MySQL and memcached with Ruby

There are a number of different modules for interfacing to `memcached` within Ruby. The `Ruby-MemCache` client library provides a native interface to `memcached` that does not require any external libraries, such as `libmemcached`. You can obtain the installer package from <http://www.deveiate.org/projects/RMemCache>.

To install, extract the package and then run `install.rb`:

```
shell> install.rb
```

If you have RubyGems, you can install the `Ruby-MemCache` gem:

```

shell> gem install Ruby-MemCache
Bulk updating Gem source index for: http://gems.rubyforge.org
Install required dependency io-reactor? [Yn] y
Successfully installed Ruby-MemCache-0.0.1
Successfully installed io-reactor-0.05
Installing ri documentation for io-reactor-0.05...
Installing RDoc documentation for io-reactor-0.05...

```

To use a `memcached` instance from within Ruby, create a new instance of the `MemCache` object.

```
require 'memcache'
memc = MemCache::new '192.168.0.100:11211'
```

You can add a weight to each server to increase the likelihood of the server being selected during hashing by appending the weight count to the server host name/port string:

```
require 'memcache'
memc = MemCache::new '192.168.0.100:11211:3'
```

To add servers to an existing list, you can append them directly to the `MemCache` object:

```
memc += ["192.168.0.101:11211"]
```

To set data into the cache, you can just assign a value to a key within the new cache object, which works just like a standard Ruby hash object:

```
memc["key"] = "value"
```

Or to retrieve the value:

```
print memc["key"]
```

For more explicit actions, you can use the method interface, which mimics the main `memcached` API functions, as summarized in the following table.

Ruby <code>MemCache</code> Method	Equivalent to
<code>get()</code>	Generic <code>get()</code>
<code>get_hash(keys)</code>	Get the values of multiple <code>keys</code> , returning the information as a hash of the keys and their values.

Ruby MemCache Method	Equivalent to
<code>set()</code>	Generic <code>set()</code>
<code>set_many(pairs)</code>	Set the values of the keys and values in the hash <code>pairs</code> .
<code>add()</code>	Generic <code>add()</code>
<code>replace()</code>	Generic <code>replace()</code>
<code>delete()</code>	Generic <code>delete()</code>
<code>incr()</code>	Generic <code>incr()</code>
<code>decr()</code>	Generic <code>decr()</code>

4.3.6. Using MySQL and memcached with Java

The `com.danga.MemCached` class within Java provides a native interface to `memcached` instances. You can obtain the client from <http://whalin.com/memcached/>. The Java class uses hashes that are compatible with `libmemcached`, so you can mix and match Java and `libmemcached` applications accessing the same `memcached` instances. The serialization between Java and other interfaces are not compatible. If this is a problem, use JSON or a similar nonbinary serialization format.

On most systems you can download the package and use the `jar` directly.

To use the `com.danga.MemCached` interface, you create a `MemCachedClient` instance and then configure the list of servers by configuring the `SockIOPool`. Through the pool specification you set up the server list, weighting, and the connection parameters to optimized the connections between your client and the `memcached` instances that you configure.

Generally you can configure the `memcached` interface once within a single class and then use this interface throughout the rest of your application.

For example, to create a basic interface, first configure the `MemCachedClient` and base `SockIOPool` settings:

```
public class MyClass {
    protected static MemCachedClient mcc = new MemCachedClient();
    static {
        String[] servers =
            {
                "localhost:11211",
            };
        Integer[] weights = { 1 };
        SockIOPool pool = SockIOPool.getInstance();
        pool.setServers( servers );
        pool.setWeights( weights );
    }
}
```

In the above sample, the list of servers is configured by creating an array of the `memcached` instances that you want to use. You can then configure individual weights for each server.

The remainder of the properties for the connection are optional, but you can set the connection numbers (initial connections, minimum connections, maximum connections, and the idle timeout) by setting the pool parameters:

```
pool.setInitConn( 5 );
pool.setMinConn( 5 );
pool.setMaxConn( 250 );
pool.setMaxIdle( 1000 * 60 * 60 * 6 );
```

Once the parameters have been configured, initialize the connection pool:

```
pool.initialize();
```

The pool, and the connection to your `memcached` instances should now be ready to use.

To set the hashing algorithm used to select the server used when storing a given key you can use `pool.setHashingAlg()`:

```
pool.setHashingAlg( SockIOPool.NEW_COMPAT_HASH );
```

Valid values are `NEW_COMPAT_HASH`, `OLD_COMPAT_HASH` and `NATIVE_HASH` are also basic modular hashing algorithms. For a consistent hashing algorithm, use `CONSISTENT_HASH`. These constants are equivalent to the corresponding hash settings within `libmemcached`.

Java <code>com.danga.MemCached</code> Method	Equivalent to
<code>get()</code>	Generic <code>get()</code>
<code>getMulti(keys)</code>	Get the values of multiple <code>keys</code> , returning the information as Hash map using <code>java.lang.String</code> for the keys and <code>java.lang.Object</code> for the corresponding values.
<code>set()</code>	Generic <code>set()</code>
<code>add()</code>	Generic <code>add()</code>
<code>replace()</code>	Generic <code>replace()</code>
<code>delete()</code>	Generic <code>delete()</code>
<code>incr()</code>	Generic <code>incr()</code>
<code>decr()</code>	Generic <code>decr()</code>

4.3.7. Using the MySQL memcached UDFs

The memcached MySQL User Defined Functions (UDFs) enable you to set and retrieve objects from within MySQL 5.0 or greater.

To install the MySQL memcached UDFs, download the UDF package from <http://libmemcached.org/>. Unpack the package and run `configure` to configure the build process. When running `configure`, use the `--with-mysql` option and specify the location of the `mysql_config` command.

```
shell> tar zxf memcached_functions_mysql-0.5.tar.gz
shell> cd memcached_functions_mysql-0.5
shell> ./configure --with-mysql-config=/usr/local/mysql/bin/mysql_config
```

Now build and install the functions:

```
shell> make
shell> make install
```

Copy the MySQL memcached UDFs into your MySQL plugins directory:

```
shell> cp /usr/local/lib/libmemcached_functions_mysql* /usr/local/mysql/lib/mysql/plugins/
```

The plugin directory is given by the value of the `plugin_dir` system variable. For more information, see [Compiling and Installing User-Defined Functions](#).

Once installed, you must initialize the function within MySQL using `CREATE` and specifying the return value and library. For example, to add the `memc_get()` function:

```
mysql> CREATE FUNCTION memc_get RETURNS STRING SONAME "libmemcached_functions_mysql.so";
```

You must repeat this process for each function that you want to provide access to within MySQL. Once you have created the association, the information is retained, even over restarts of the MySQL server. You can simplify the process by using the SQL script provided in the memcached UDFs package:

```
shell> mysql <sql/install_functions.sql
```

Alternatively, if you have Perl installed, then you can use the supplied Perl script, which checks for the existence of each function and creates the function/library association if it is not already defined:

```
shell> utils/install.pl --silent
```

The `--silent` option installs everything automatically. Without this option, the script asks whether you want to install each of the available functions.

The interface remains consistent with the other APIs and interfaces. To set up a list of servers, use the `memc_servers_set()` function, which accepts a single string containing and comma-separated list of servers:

```
mysql> SELECT memc_servers_set('192.168.0.1:11211,192.168.0.2:11211');
```

■ Note

The list of servers used by the `memcached` UDFs is not persistent over restarts of the MySQL server. If the MySQL server fails, then you must re-set the list of `memcached` servers.

To set a value, use `memc_set()`:

```
mysql> SELECT memc_set('myid', 'myvalue');
```

To retrieve a stored value:

```
mysql> SELECT memc_get('myid');
```

The list of functions supported by the UDFs, in relation to the standard protocol functions, is shown in the following table.

MySQL <code>memcached</code> UDF Function	Equivalent to
<code>memc_get()</code>	Generic <code>get()</code>
<code>memc_get_by_key(master_key, key, value)</code>	Like the generic <code>get()</code> , but uses the supplied master key to select the server to use.
<code>memc_set()</code>	Generic <code>set()</code>
<code>memc_set_by_key(master_key, key, value)</code>	Like the generic <code>set()</code> , but uses the supplied master key to select the server to use.
<code>memc_add()</code>	Generic <code>add()</code>
<code>memc_add_by_key(master_key, key, value)</code>	Like the generic <code>add()</code> , but uses the supplied master key to select the server to use.
<code>memc_replace()</code>	Generic <code>replace()</code>
<code>memc_replace_by_key(master_key, key, value)</code>	Like the generic <code>replace()</code> , but uses the supplied master key to select the server to use.
<code>memc_prepend(key, value)</code>	Prepend the specified <code>value</code> to the current value of the specified <code>key</code> .
<code>memc_prepend_by_key(master_key, key, value)</code>	Prepend the specified <code>value</code> to the current value of the specified <code>key</code> , but uses the supplied master key to select the server to use.
<code>memc_append(key, value)</code>	Append the specified <code>value</code> to the current value of the specified <code>key</code> .
<code>memc_append_by_key(master_key, key, value)</code>	Append the specified <code>value</code> to the current value of the specified <code>key</code> , but uses the supplied master key to select the server to use.
<code>memc_delete()</code>	Generic <code>delete()</code>
<code>memc_delete_by_key(master_key, key, value)</code>	Like the generic <code>delete()</code> , but uses the supplied master key to select the server to use.
<code>memc_increment()</code>	Generic <code>incr()</code>
<code>memc_decrement()</code>	Generic <code>decr()</code>

The respective `*_by_key()` functions are useful when you want to store a specific value into a specific `memcached` server, possibly based on a differently calculated or constructed key.

The `memcached` UDFs include some additional functions:

- `memc_server_count()`

Returns a count of the number of servers in the list of registered servers.

- `memc_servers_set_behavior(behavior_type, value), memc_set_behavior(behavior_type, value)`

Set behaviors for the list of servers. These behaviors are identical to those provided by the `libmemcached` library. For more information on `libmemcached` behaviors, see [Section 4.3.1, “Using libmemcached”](#).

You can use the behavior name as the `behavior_type`:

```
mysql> SELECT memc_servers_behavior_set("MEMCACHED_BEHAVIOR_KETAMA",1);
```

- `memc_servers_behavior_get(behavior_type), memc_get_behavior(behavior_type, value)`
Returns the value for a given behavior.
- `memc_list_behaviors()`
Returns a list of the known behaviors.
- `memc_list_hash_types()`
Returns a list of the supported key-hashing algorithms.
- `memc_list_distribution_types()`
Returns a list of the supported distribution types to be used when selecting a server to use when storing a particular key.
- `memc_libmemcached_version()`
Returns the version of the `libmemcached` library.
- `memc_stats()`
Returns the general statistics information from the server.

4.3.8. memcached Protocol

Communicating with a `memcached` server can be achieved through either the TCP or UDP protocols. When using the TCP protocol you can use a simple text based interface for the exchange of information.

4.3.8.1. Using the TCP text protocol

When communicating with `memcached` you can connect to the server using the port configured for the server. You can open a connection with the server without requiring authorization or login. As soon as you have connected, you can start to send commands to the server. When you have finished, you can terminate the connection without sending any specific disconnection command. Clients are encouraged to keep their connections open to decrease latency and improve performance.

Data is sent to the `memcached` server in two forms:

- Text lines, which are used to send commands to the server, and receive responses from the server.
- Unstructured data, which is used to receive or send the value information for a given key. Data is returned to the client in exactly the format it was provided.

Both text lines (commands and responses) and unstructured data are always terminated with the string `\r\n`. Because the data being stored may contain this sequence, the length of the data (returned by the client before the unstructured data is transmitted) should be used to determine the end of the data.

Commands to the server are structured according to their operation:

- **Storage commands:** `set`, `add`, `replace`, `append`, `prepend`, `cas`

Storage commands to the server take the form:

```
command key [flags] [exptime] length [noreply]
```

Or when using compare and swap (`cas`):

```
cas key [flags] [exptime] length [casunique] [noreply]
```

Where:

- `command`: The command name.
 - `set`: Store value against key
 - `add`: Store this value against key if the key does not already exist

- **replace**: Store this value against key if the key already exists
- **append**: Append the supplied value to the end of the value for the specified key. The **flags** and **exptime** arguments should not be used.
- **prepend**: Append value currently in the cache to the end of the supplied value for the specified key. The **flags** and **exptime** arguments should not be used.
- **cas**: Set the specified key to the supplied value, only if the supplied **casunique** matches. This is effectively the equivalent of change the information if nobody has updated it since I last fetched it.
- **key**: The key. All data is stored using a the specific key. The key cannot contain control characters or whitespace, and can be up to 250 characters in size.
- **flags**: The flags for the operation (as an integer). Flags in **memcached** are transparent. The **memcached** server ignores the contents of the flags. They can be used by the client to indicate any type of information. In **memcached** 1.2.0 and lower the value is a 16-bit integer value. In **memcached** 1.2.1 and higher the value is a 32-bit integer.
- **exptime**: The expiry time, or zero for no expiry.
- **length**: The length of the supplied value block in bytes, excluding the terminating `\r\n` characters.
- **casunique**: A unique 64-bit value of an existing entry. This is used to compare against the existing value. Use the value returned by the **gets** command when issuing **cas** updates.
- **noreply**: Tells the server not to reply to the command.

For example, to store the value `abcdef` into the key `xyzkey`, you would use:

```
set xyzkey 0 0 6\r\nabcdef\r\n
```

The return value from the server is one line, specifying the status or error information. For more information, see [Table 4.2, “memcached Protocol Responses”](#).

- **Retrieval commands**: `get`, `gets`

Retrieval commands take the form:

```
get key1 [key2 ... keyn]
gets key1 [key2 ... keyn]
```

You can supply multiple keys to the commands, with each requested key separated by whitespace.

The server responds with an information line of the form:

```
VALUE key flags bytes [casunique]
```

Where:

- **key**: The key name.
- **flags**: The value of the flag integer supplied to the **memcached** server when the value was stored.
- **bytes**: The size (excluding the terminating `\r\n` character sequence) of the stored value.
- **casunique**: The unique 64-bit integer that identifies the item.

The information line is immediately followed by the value data block. For example:

```
get xyzkey\r\n
VALUE xyzkey 0 6\r\n
abcdef\r\n
```

If you have requested multiple keys, an information line and data block is returned for each key found. If a requested key does not exist in the cache, no information is returned.

- **Delete commands**: `delete`

Deletion commands take the form:

```
delete key [time] [noreply]
```

Where:

- **key**: The key name.
- **time**: The time in seconds (or a specific Unix time) for which the client wishes the server to refuse `add` or `replace` commands on this key. All `add`, `replace`, `get`, and `gets` commands fail during this period. `set` operations succeed. After this period, the key is deleted permanently and all commands are accepted.

If not supplied, the value is assumed to be zero (delete immediately).

- **noreply**: Tells the server not to reply to the command.

Responses to the command are either `DELETED` to indicate that the key was successfully removed, or `NOT_FOUND` to indicate that the specified key could not be found.

- **Increment/Decrement**: `incr`, `decr`

The increment and decrement commands change the value of a key within the server without performing a separate `get/set` sequence. The operations assume that the currently stored value is a 64-bit integer. If the stored value is not a 64-bit integer, then the value is assumed to be zero before the increment or decrement operation is applied.

Increment and decrement commands take the form:

```
incr key value [noreply]
decr key value [noreply]
```

Where:

- **key**: The key name.
- **value**: An integer to be used as the increment or decrement value.
- **noreply**: Tells the server not to reply to the command.

The response is:

- **NOT_FOUND**: The specified key could not be located.
- **value**: The new value of the specified key.

Values are assumed to be unsigned. For `decr` operations the value is never decremented below 0. For `incr` operations, the value wraps around the 64-bit maximum.

- **Statistics commands**: `stats`

The `stats` command provides detailed statistical information about the current status of the `memcached` instance and the data it is storing.

Statistics commands take the form:

```
STAT [name] [value]
```

Where:

- **name**: The optional name of the statistics to return. If not specified, the general statistics are returned.
- **value**: A specific value to be used when performing certain statistics operations.

The return value is a list of statistics data, formatted as follows:

```
STAT name value
```

The statistics are terminated with a single line, `END`.

For more information, see [Section 4.4, “Getting memcached Statistics”](#).

For reference, a list of the different commands supported and their formats is provided below.

Table 4.1. memcached Command Reference

Command	Command Formats
set	set key flags exptime length, set key flags exptime length noreply
add	add key flags exptime length, add key flags exptime length noreply
replace	replace key flags exptime length, replace key flags exptime length noreply
append	append key length, append key length noreply
prepend	prepend key length, prepend key length noreply
cas	cas key flags exptime length casunique, cas key flags exptime length casunique noreply
get	get key1 [key2 ... keyn]
gets	
delete	delete key, delete key noreply, delete key expiry, delete key expiry noreply
incr	incr key, incr key noreply, incr key value, incr key value noreply
decr	decr key, decr key noreply, decr key value, decr key value noreply
stat	stat, stat name, stat name value

When sending a command to the server, the response from the server is one of the settings in the following table. All response values from the server are terminated by `\r\n`:

Table 4.2. memcached Protocol Responses

String	Description
STORED	Value has successfully been stored.
NOT_STORED	The value was not stored, but not because of an error. For commands where you are adding a or updating a value if it exists (such as <code>add</code> and <code>replace</code>), or where the item has already been set to be deleted.
EXISTS	When using a <code>cas</code> command, the item you are trying to store already exists and has been modified since you last checked it.
NOT_FOUND	The item you are trying to store, update or delete does not exist or has already been deleted.
ERROR	You submitted a nonexistent command name.
CLIENT_ERROR <code>error-string</code>	There was an error in the input line, the detail is contained in <code>errorstring</code> .
SERVER_ERROR <code>error-string</code>	There was an error in the server that prevents it from returning the information. In extreme conditions, the server may disconnect the client after this error occurs.
VALUE <code>keys flags length</code>	The requested key has been found, and the stored <code>key</code> , <code>flags</code> and data block are returned, of the specified <code>length</code> .
DELETED	The requested key was deleted from the server.
STAT <code>name value</code>	A line of statistics data.
END	The end of the statistics data.

4.4. Getting memcached Statistics

The `memcached` system has a built in statistics system that collects information about the data being stored into the cache, cache hit ratios, and detailed information on the memory usage and distribution of information through the slab allocation used to store individual items. Statistics are provided at both a basic level that provide the core statistics, and more specific statistics for specific areas of the `memcached` server.

This information can prove be very useful to ensure that you are getting the correct level of cache and memory usage, and that your slab allocation and configuration properties are set at an optimal level.

The stats interface is available through the standard `memcached` protocol, so the reports can be accessed by using `telnet` to connect to the `memcached`. The supplied `memcached-tool` includes support for obtaining the [Section 4.4.2, “memcached Slabs Statistics”](#) and [Section 4.4.1, “memcached General Statistics”](#) information. For more information, see [Section 4.4.6, “Using memcached-tool”](#).

Alternatively, most of the language API interfaces provide a function for obtaining the statistics from the server.

For example, to get the basic stats using `telnet`:

```
shell> telnet localhost 11211
Trying ::1...
Connected to localhost.
Escape character is '^]'.
stats
STAT pid 23599
STAT uptime 675
STAT time 1211439587
STAT version 1.2.5
STAT pointer_size 32
STAT rusage_user 1.404992
STAT rusage_system 4.694685
STAT curr_items 32
STAT total_items 56361
STAT bytes 2642
STAT curr_connections 53
STAT total_connections 438
STAT connection_structures 55
STAT cmd_get 113482
STAT cmd_set 80519
STAT get_hits 78926
STAT get_misses 34556
STAT evictions 0
STAT bytes_read 6379783
STAT bytes_written 4860179
STAT limit_maxbytes 67108864
STAT threads 1
END
```

When using Perl and the `Cache::Memcached` module, the `stats()` function returns information about all the servers currently configured in the connection object, and total statistics for all the `memcached` servers as a whole.

For example, the following Perl script obtains the stats and dumps the hash reference that is returned:

```
use Cache::Memcached;
use Data::Dumper;
my $memc = new Cache::Memcached;
$memc->set_servers(\@ARGV);
print Dumper($memc->stats());
```

When executed on the same `memcached` as used in the `Telnet` example above we get a hash reference with the host by host and total statistics:

```
$VAR1 = {
  'hosts' => {
    'localhost:11211' => {
      'misc' => {
        'bytes' => '2421',
        'curr_connections' => '3',
        'connection_structures' => '56',
        'pointer_size' => '32',
        'time' => '1211440166',
        'total_items' => '410956',
        'cmd_set' => '588167',
        'bytes_written' => '35715151',
        'evictions' => '0',
        'curr_items' => '31',
        'pid' => '23599',
        'limit_maxbytes' => '67108864',
        'uptime' => '1254',
        'rusage_user' => '9.857805',
        'cmd_get' => '838451',
        'rusage_system' => '34.096988',
        'version' => '1.2.5',
        'get_hits' => '581511',
        'bytes_read' => '46665716',
        'threads' => '1',
        'total_connections' => '3104',
        'get_misses' => '256940'
      },
      'sizes' => {
        '128' => '16',
        '64' => '15'
      }
    }
  },
  'self' => {},
  'total' => {
    'cmd_get' => 838451,
```



```
'bytes' => 2421,
'get_hits' => 581511,
'connection_structures' => 56,
'bytes_read' => 46665716,
'total_items' => 410956,
'total_connections' => 3104,
'cmd_set' => 588167,
'bytes_written' => 35715151,
'curr_items' => 31,
'get_misses' => 256940
};
```

The statistics are divided up into a number of distinct sections, and then can be requested by adding the type to the `stats` command. Each statistics output is covered in more detail in the following sections.

- General statistics, see [Section 4.4.1, “memcached General Statistics”](#).
- Slab statistics (`slabs`), see [Section 4.4.2, “memcached Slabs Statistics”](#).
- Item statistics (`items`), see [Section 4.4.3, “memcached Item Statistics”](#).
- Size statistics (`sizes`), see [Section 4.4.4, “memcached Size Statistics”](#).
- Detailed status (`detail`), see [Section 4.4.5, “memcached Detail Statistics”](#).

4.4.1. memcached General Statistics

The output of the general statistics provides an overview of the performance and use of the `memcached` instance. The statistics returned by the command and their meaning is shown in the following table.

The following terms are used to define the value type for each statistics value:

- `32u`: 32-bit unsigned integer
- `64u`: 64-bit unsigned integer
- `32u32u`: Two 32-bit unsigned integers separated by a colon
- `String`: Character string

Statistic	Data type	Description	Version
pid	32u	Process ID of the <code>memcached</code> instance.	
uptime	32u	Uptime (in seconds) for this <code>memcached</code> instance.	
time	32u	Current time (as epoch).	
version	string	Version string of this instance.	
pointer_size	string	Size of pointers for this host specified in bits (32 or 64).	
rusage_user	32u:32u	Total user time for this instance (seconds:microseconds).	
rusage_system	32u:32u	Total system time for this instance (seconds:microseconds).	
curr_items	32u	Current number of items stored by this instance.	
total_items	32u	Total number of items stored during the life of this instance.	
bytes	64u	Current number of bytes used by this server to store items.	
curr_connections	32u	Current number of open connections.	
total_connections	32u	Total number of connections opened since the server started running.	
connection_structures	32u	Number of connection structures allocated by the server.	
cmd_get	64u	Total number of retrieval requests (<code>get</code> operations).	
cmd_set	64u	Total number of storage requests (<code>set</code> operations).	
get_hits	64u	Number of keys that have been requested and found present.	
get_misses	64u	Number of items that have been requested and not found.	
delete_hits	64u	Number of keys that have been deleted and found present.	1.3.x
delete_misses	64u	Number of items that have been delete and not found.	1.3.x

Statistic	Data type	Description	Version
incr_hits	64u	Number of keys that have been incremented and found present.	1.3.x
incr_misses	64u	Number of items that have been incremented and not found.	1.3.x
decr_hits	64u	Number of keys that have been decremented and found present.	1.3.x
decr_misses	64u	Number of items that have been decremented and not found.	1.3.x
cas_hits	64u	Number of keys that have been compared and swapped and found present.	1.3.x
cas_misses	64u	Number of items that have been compared and swapped and not found.	1.3.x
cas_badvalue	64u	Number of keys that have been compared and swapped, but the comparison (original) value did not match the supplied value.	1.3.x
evictions	64u	Number of valid items removed from cache to free memory for new items.	
bytes_read	64u	Total number of bytes read by this server from network.	
bytes_written	64u	Total number of bytes sent by this server to network.	
limit_maxbytes	32u	Number of bytes this server is permitted to use for storage.	
threads	32u	Number of worker threads requested.	
conn_yields	64u	Number of yields for connections (related to the <code>-R</code> option).	1.4.0

The most useful statistics from those given here are the number of cache hits, misses, and evictions.

A large number of `get_misses` may just be an indication that the cache is still being populated with information. The number should, over time, decrease in comparison to the number of cache `get_hits`. If, however, you have a large number of cache misses compared to cache hits after an extended period of execution, it may be an indication that the size of the cache is too small and you either need to increase the total memory size, or increase the number of the `memcached` instances to improve the hit ratio.

A large number of `evictions` from the cache, particularly in comparison to the number of items stored is a sign that your cache is too small to hold the amount of information that you regularly want to keep cached. Instead of items being retained in the cache, items are being evicted to make way for new items keeping the turnover of items in the cache high, reducing the efficiency of the cache.

4.4.2. memcached Slabs Statistics

To get the `slabs` statistics, use the `stats slabs` command, or the API equivalent.

The slab statistics provide you with information about the slabs that have created and allocated for storing information within the cache. You get information both on each individual slab-class and total statistics for the whole slab.

```
STAT 1:chunk_size 104
STAT 1:chunks_per_page 10082
STAT 1:total_pages 1
STAT 1:total_chunks 10082
STAT 1:used_chunks 10081
STAT 1:free_chunks 1
STAT 1:free_chunks_end 10079
STAT 9:chunk_size 696
STAT 9:chunks_per_page 1506
STAT 9:total_pages 63
STAT 9:total_chunks 94878
STAT 9:used_chunks 94878
STAT 9:free_chunks 0
STAT 9:free_chunks_end 0
STAT active_slabs 2
STAT total_malloced 67083616
END
```

Individual stats for each slab class are prefixed with the slab ID. A unique ID is given to each allocated slab from the smallest size up to the largest. The prefix number indicates the slab class number in relation to the calculated chunk from the specified growth factor. Hence in the example, 1 is the first chunk size and 9 is the 9th chunk allocated size.

The different parameters returned for each chunk size and the totals are shown in the following table.

Statistic	Description	Version
chunk_size	Space allocated to each chunk within this slab class.	
chunks_per_page	Number of chunks within a single page for this slab class.	

Statistic	Description	Version
total_pages	Number of pages allocated to this slab class.	
total_chunks	Number of chunks allocated to the slab class.	
used_chunks	Number of chunks allocated to an item..	
free_chunks	Number of chunks not yet allocated to items.	
free_chunks_end	Number of free chunks at the end of the last allocated page.	
get_hits	Number of get hits to this chunk	1.3.x
cmd_set	Number of set commands on this chunk	1.3.x
delete_hits	Number of delete hits to this chunk	1.3.x
incr_hits	Number of increment hits to this chunk	1.3.x
decr_hits	Number of decrement hits to this chunk	1.3.x
cas_hits	Number of CAS hits to this chunk	1.3.x
cas_badval	Number of CAS hits on this chunk where the existing value did not match	1.3.x
mem_requested	The true amount of memory of memory requested within this chunk	1.4.1

The following additional statistics cover the information for the entire server, rather than on a chunk by chunk basis:

Statistic	Description	Version
active_slabs	Total number of slab classes allocated.	
total_malloced	Total amount of memory allocated to slab pages.	

The key values in the slab statistics are the `chunk_size`, and the corresponding `total_chunks` and `used_chunks` parameters. These give an indication of the size usage of the chunks within the system. Remember that one key/value pair is placed into a chunk of a suitable size.

From these stats, you can get an idea of your size and chunk allocation and distribution. If you store many items with a number of largely different sizes, then you may want to adjust the chunk size growth factor to increase in larger steps to prevent chunk and memory wastage. A good indication of a bad growth factor is a high number of different slab classes, but with relatively few chunks actually in use within each slab. Increasing the growth factor creates fewer slab classes and therefore makes better use of the allocated pages.

4.4.3. memcached Item Statistics

To get the `items` statistics, use the `stats items` command, or the API equivalent.

The `items` statistics give information about the individual items allocated within a given slab class.

```
STAT items:2:number 1
STAT items:2:age 452
STAT items:2:evicted 0
STAT items:2:evicted_nonzero 0
STAT items:2:evicted_time 2
STAT items:2:outofmemory 0
STAT items:2:tailrepairs 0
...
STAT items:27:number 1
STAT items:27:age 452
STAT items:27:evicted 0
STAT items:27:evicted_nonzero 0
STAT items:27:evicted_time 2
STAT items:27:outofmemory 0
STAT items:27:tailrepairs 0
```

The prefix number against each statistics relates to the corresponding chunk size, as returned by the `stats slabs` statistics. The

result is a display of the number of items stored within each chunk within each slab size, and specific statistics about their age, eviction counts, and out of memory counts. A summary of the statistics is given in the following table.

Statistic	Description	
<code>number</code>	The number of items currently stored in this slab class.	
<code>age</code>	The age of the oldest item within the slab class, in seconds.	
<code>evicted</code>	The number of items evicted to make way for new entries.	
<code>evicted_time</code>	The time of the last evicted entry	
<code>evicted_nonzero</code>	The time of the last evicted non-zero entry	1.4.0
<code>outofmemory</code>	The number of items for this slab class that have triggered an out of memory error (only value when the <code>-M</code> command line option is in effect).	
<code>tailrepairs</code>	Number of times the entries for a particular ID need repairing	

Item level statistics can be used to determine how many items are stored within a given slab and their freshness and recycle rate. You can use this to help identify whether there are certain slab classes that are triggering a much larger number of evictions than others.

4.4.4. memcached Size Statistics

To get size statistics, use the `stats sizes` command, or the API equivalent.

The size statistics provide information about the sizes and number of items of each size within the cache. The information is returned as two columns, the first column is the size of the item (rounded up to the nearest 32 byte boundary), and the second column is the count of the number of items of that size within the cache:

```
96 35
128 38
160 807
192 804
224 410
256 222
288 83
320 39
352 53
384 33
416 64
448 51
480 30
512 54
544 39
576 10065
```

Caution

Running this statistic locks up your cache as each item is read from the cache and its size calculated. On a large cache, this may take some time and prevent any set or get operations until the process completes.

The item size statistics are useful only to determine the sizes of the objects you are storing. Since the actual memory allocation is relevant only in terms of the chunk size and page size, the information is only useful during a careful debugging or diagnostic session.

4.4.5. memcached Detail Statistics

For `memcached` 1.3.x and higher, you can enable and obtain detailed statistics about the `get`, `set`, and `del` operations on the individual keys stored in the cache, and determine whether the attempts hit (found) a particular key. These operations are only recorded while the detailed stats analysis is turned on.

To enable detailed statistics, you must send the `stats detail on` command to the `memcached` server:

```
$ telnet localhost 11211
Trying 127.0.0.1...
Connected to tiger.
Escape character is '^]'.
stats detail on
OK
```

Individual statistics are recorded for every `get`, `set` and `del` operation on a key, including keys that are not currently stored in the server. For example, if an attempt is made to obtain the value of key `abckey` and it does not exist, the `get` operation on the specified key are recorded while detailed statistics are in effect, even if the key is not currently stored. The `hits`, that is, the number of `get` or `del` operations for a key that exists in the server are also counted.

To turn detailed statistics off, send the `stats detail off` command to the memcached server:

```
$ telnet localhost 11211
Trying 127.0.0.1...
Connected to tiger.
Escape character is '^]'.
stats detail on
OK
```

To obtain the detailed statistics recorded during the process, send the `stats detail dump` command to the memcached server:

```
stats detail dump
PREFIX hykkey get 0 hit 0 set 1 del 0
PREFIX xyzkey get 0 hit 0 set 1 del 0
PREFIX yukkey get 1 hit 0 set 0 del 0
PREFIX abckey get 3 hit 3 set 1 del 0
END
```

You can use the detailed statistics information to determine whether your memcached clients are using a large number of keys that do not exist in the server by comparing the `hit` and `get` or `del` counts. Because the information is recorded by key, you can also determine whether the failures or operations are clustered around specific keys.

4.4.6. Using memcached-tool

The `memcached-tool`, located within the `scripts` directory within the `memcached` source directory. The tool provides convenient access to some reports and statistics from any memcached instance.

The basic format of the command is:

```
shell> ./memcached-tool hostname:port [command]
```

The default output produces a list of the slab allocations and usage. For example:

```
shell> memcached-tool localhost:11211 display
# Item_Size Max_age Pages Count Full? Evicted Evict_Time OOM
1 80B 93s 1 20 no 0 0 0
2 104B 93s 1 16 no 0 0 0
3 136B 1335s 1 28 no 0 0 0
4 176B 1335s 1 24 no 0 0 0
5 224B 1335s 1 32 no 0 0 0
6 280B 1335s 1 34 no 0 0 0
7 352B 1335s 1 36 no 0 0 0
8 440B 1335s 1 46 no 0 0 0
9 552B 1335s 1 58 no 0 0 0
10 696B 1335s 1 66 no 0 0 0
11 872B 1335s 1 89 no 0 0 0
12 1.1K 1335s 1 112 no 0 0 0
13 1.3K 1335s 1 145 no 0 0 0
14 1.7K 1335s 1 123 no 0 0 0
15 2.1K 1335s 1 198 no 0 0 0
16 2.6K 1335s 1 199 no 0 0 0
17 3.3K 1335s 1 229 no 0 0 0
18 4.1K 1335s 1 248 yes 36 2 0
19 5.2K 1335s 2 328 no 0 0 0
20 6.4K 1335s 2 316 yes 387 1 0
21 8.1K 1335s 3 381 yes 492 1 0
22 10.1K 1335s 3 303 yes 598 2 0
23 12.6K 1335s 5 405 yes 605 1 0
24 15.8K 1335s 6 384 yes 766 2 0
25 19.7K 1335s 7 357 yes 908 170 0
26 24.6K 1336s 7 287 yes 1012 1 0
27 30.8K 1336s 7 231 yes 1193 169 0
28 38.5K 1336s 4 104 yes 1323 169 0
29 48.1K 1336s 1 21 yes 1287 1 0
30 60.2K 1336s 1 17 yes 1093 169 0
31 75.2K 1337s 1 13 yes 713 168 0
32 94.0K 1337s 1 10 yes 278 168 0
33 117.5K 1336s 1 3 no 0 0 0
```

This output is the same if you specify the `command` as `display`:

```
shell> memcached-tool localhost:11211 display
# Item_Size Max_age Pages Count Full? Evicted Evict_Time OOM
1 80B 93s 1 20 no 0 0 0
2 104B 93s 1 16 no 0 0 0
...
```

The output shows a summarized version of the output from the `slabs` statistics. The columns provided in the output are shown below:

- #: The slab number
- `Item_Size`: The size of the slab
- `Max_age`: The age of the oldest item in the slab
- `Pages`: The number of pages allocated to the slab
- `Count`: The number of items in this slab
- `Full?`: Whether the slab is fully populated
- `Evicted`: The number of objects evicted from this slab
- `Evict_Time`: The time (in seconds) since the last eviction
- `OOM`: The number of items that have triggered an out of memory error

You can also obtain a dump of the general statistics for the server using the `stats` command:

```
shell> memcached-tool localhost:11211 stats
#localhost:11211 Field      Value
      accepting_conns      1
      bytes                 162
      bytes_read            485
      bytes_written         6820
      cas_badval            0
      cas_hits              0
      cas_misses            0
      cmd_flush             0
      cmd_get               4
      cmd_set               2
      conn_yields           0
      connection_structures 11
      curr_connections      10
      curr_items            2
      decr_hits             0
      decr_misses           1
      delete_hits           0
      delete_misses         0
      evictions             0
      get_hits              4
      get_misses            0
      incr_hits             0
      incr_misses           2
      limit_maxbytes        67108864
      listen_disabled_num   0
      pid                   12981
      pointer_size          32
      rusage_system         0.013911
      rusage_user           0.011876
      threads               4
      time                  1255518565
      total_connections     20
      total_items           2
      uptime                880
      version                1.4.2
```

The `memcached-tool` provides

4.5. memcached FAQ

Questions

- [4.5.1](#): Can MySQL actually trigger/store the changed data to memcached?
- [4.5.2](#): Can memcached be run on a Windows environment?
- [4.5.3](#): Does the `-L` flag automatically sense how much memory is being used by other memcached?
- [4.5.4](#): What is the max size of an object you can store in memcache and is that configurable?
- [4.5.5](#): Is it true `memcached` will be much more effective with db-read-intensive applications than with db-write-intensive applications?
- [4.5.6](#): `memcached` is fast - is there any overhead in not using persistent connections? If persistent is always recommended, what are the downsides (for example, locking up)?

- [4.5.7](#): How does an event such as a crash of one of the `memcached` servers handled by the `memcached` client?
- [4.5.8](#): What's a recommended hardware config for a memcached server? Linux or Windows?
- [4.5.9](#): Doing a direct telnet to the memcached port, is that just for that one machine, or does it magically apply across all nodes?
- [4.5.10](#): Is memcached more effective for video and audio as opposed to textual read/writes
- [4.5.11](#): If you log a complex class (with methods that do calculation etc) will the get from Memcache re-create the class on the way out?
- [4.5.12](#): If I have an object larger than a MB, do I have to manually split it or can I configure `memcached` to handle larger objects?
- [4.5.13](#): Can `memcached` work with `ASPX`?
- [4.5.14](#): Are there any, or are there any plans to introduce, a framework to hide the interaction of memcached from the application; that is, within hibernate?
- [4.5.15](#): So the responsibility lies with the application to populate and get records from the database as opposed to being a transparent cache layer for the db?
- [4.5.16](#): How does `memcached` compare to nCache?
- [4.5.17](#): We are caching XML by serialising using `saveXML()`, because PHP cannot serialise DOM objects; Some of the XML is variable and is modified per-request. Do you recommend caching then using XPath, or is it better to rebuild the DOM from separate node-groups?
- [4.5.18](#): How easy is it to introduce `memcached` to an existing enterprise application instead of inclusion at project design?
- [4.5.19](#): Do the memcache UDFs work under 5.1?
- [4.5.20](#): Is the data inside of `memcached` secure?
- [4.5.21](#): Is `memcached` typically a better solution for improving speed than MySQL Cluster and/or MySQL Proxy?
- [4.5.22](#): File socket support for `memcached` from the localhost use to the local memcached server?
- [4.5.23](#): How expensive is it to establish a memcache connection? Should those connections be pooled?
- [4.5.24](#): What are the advantages of using UDFs when the get/sets are manageable from within the client code rather than the db?
- [4.5.25](#): How will the data will be handled when the `memcached` server is down?
- [4.5.26](#): How are auto-increment columns in the MySQL database coordinated across multiple instances of memcached?
- [4.5.27](#): Is compression available?
- [4.5.28](#): What speed trade offs is there between `memcached` vs MySQL Query Cache? Where you check `memcached`, and get data from MySQL and put it in `memcached` or just make a query and results are put into MySQL Query Cache.
- [4.5.29](#): Can we implement different types of `memcached` as different nodes in the same server - so can there be deterministic and non deterministic in the same server?
- [4.5.30](#): What are best practices for testing an implementation, to ensure that it is an improvement over the MySQL query cache, and to measure the impact of `memcached` configuration changes? And would you recommend keeping the configuration very simple to start?

Questions and Answers

4.5.1: Can MySQL actually trigger/store the changed data to memcached?

Yes. You can use the MySQL UDFs for `memcached` and either write statements that directly set the values in the `memcached` server, or use triggers or stored procedures to do it for you. For more information, see [Section 4.3.7, "Using the MySQL memcached UDFs"](#)

4.5.2: Can memcached be run on a Windows environment?

No. Currently `memcached` is available only on the Unix/Linux platform. There is an unofficial port available, see <http://www.codeplex.com/memcachedproviders>.

4.5.3: Does the `-I` flag automatically sense how much memory is being used by other `memcached`?

No. There is no communication or sharing of information between `memcached` instances.

4.5.4: What is the max size of an object you can store in memcache and is that configurable?

The default maximum object size is 1MB. In `memcached` 1.4.2 and later you can change the maximum size of an object using the `-I` command line option.

For versions before this, to increase this size, you have to re-compile `memcached`. You can modify the value of the `POWER_BLOCK` within the `slabs.c` file within the source.

In `memcached` 1.4.2 and higher you can configure the maximum supported object size by using the `-I` command-line option. For example, to increase the maximum object size to 5MB:

```
$ memcached -I 5m
```

4.5.5: Is it true `memcached` will be much more effective with db-read-intensive applications than with db-write-intensive applications?

Yes. `memcached` plays no role in database writes, it is a method of caching data already read from the database in RAM.

4.5.6: `memcached` is fast - is there any overhead in not using persistent connections? If persistent is always recommended, what are the downsides (for example, locking up)?

If you don't use persistent connections when communicating with `memcached` then there will be a small increase in the latency of opening the connection each time. The effect is comparable to use nonpersistent connections with MySQL.

In general, the chance of locking or other issues with persistent connections is minimal, because there is very little locking within `memcached`. If there is a problem then eventually your request will timeout and return no result so your application will need to load from MySQL again.

4.5.7: How does an event such as a crash of one of the `memcached` servers handled by the `memcached` client?

There is no automatic handling of this. If your client fails to get a response from a server then it should fall back to loading the data from the MySQL database.

The client APIs all provide the ability to add and remove `memcached` instances on the fly. If within your application you notice that `memcached` server is no longer responding, you can remove the server from the list of servers, and keys will automatically be redistributed to another `memcached` server in the list. If retaining the cache content on all your servers is important, make sure you use an API that supports a consistent hashing algorithm. For more information, see [Section 4.2.4, “memcached Hashing/Distribution Types”](#).

4.5.8: What's a recommended hardware config for a `memcached` server? Linux or Windows?

`memcached` is only available on Unix/Linux, so using a Windows machine is not an option. Outside of this, `memcached` has a very low processing overhead. All that is required is spare physical RAM capacity. The point is not that you should necessarily deploy a dedicated `memcached` server. If you have web, application, or database servers that have spare RAM capacity, then use them with `memcached`.

If you want to build and deploy a dedicated `memcached` servers, then you use a relatively low-power CPU, lots of RAM and one or more Gigabit Ethernet interfaces.

4.5.9: Doing a direct telnet to the `memcached` port, is that just for that one machine, or does it magically apply across all nodes?

Just one. There is no communication between different instances of `memcached`, even if each instance is running on the same machine.

4.5.10: Is `memcached` more effective for video and audio as opposed to textual read/writes

`memcached` doesn't care what information you are storing. To `memcached`, any value you store is just a stream of data. Remember, though, that the maximum size of an object you can store in `memcached` is 1MB, but can be configured to be larger by using the `-I` option in `memcached` 1.4.2 and later, or by modifying the source in versions before 1.4.2. If you plan on using `memcached` with audio and video content you will probably want to increase the maximum object size. Also remember that `memcached` is a solution for caching information for reading. It shouldn't be used for writes, except when updating the information in the cache.

4.5.11: If you log a complex class (with methods that do calculation etc) will the get from Memcache re-create the class on the way out?

In general, yes. If the serialization method within the API/language that you are using supports it, then methods and other information will be stored and retrieved.

4.5.12: If I have an object larger than a MB, do I have to manually split it or can I configure memcached to handle larger objects?

You would have to manually split it. memcached is very simple, you give it a key and some data, it tries to cache it in RAM. If you try to store more than the default maximum size, the value is just truncated for speed reasons.

4.5.13: Can memcached work with ASPX?

There are ports and interfaces for many languages and environments. ASPX relies on an underlying language such as C# or Visual-Basic, and if you are using ASP.NET then there is a C# memcached library. For more information, see .

4.5.14: Are there any, or are there any plans to introduce, a framework to hide the interaction of memcached from the application; that is, within hibernate?

There are lots of projects working with memcached. There is a Google Code implementation of Hibernate and memcached working together. See <http://code.google.com/p/hibernate-memcached/>.

4.5.15: So the responsibility lies with the application to populate and get records from the database as opposed to being a transparent cache layer for the db?

Yes. You load the data from the database and write it into the cache provided by memcached. Using memcached as a simple database row cache, however, is probably inefficient. The best way to use memcached is to load all of the information from the database relating to a particular object, and then cache the entire object. For example, in a blogging environment, you might load the blog, associated comments, categories and so on, and then cache all of the information relating to that blog post. The reading of the data from the database will require multiple SQL statements and probably multiple rows of data to complete, which is time consuming. Loading the entire blog post and the associated information from memcached is just one operation and doesn't involve using the disk or parsing the SQL statement.

4.5.16: How does memcached compare to nCache?

The main benefit of memcached is that is very easy to deploy and works with a wide range of languages and environments, including .NET, Java, Perl, Python, PHP, even MySQL. memcached is also very lightweight in terms of systems and requirements, and you can easily add as many or as few memcached servers as you need without changing the individual configuration. memcached does require additional modifications to the application to take advantage of functionality such as multiple memcached servers.

4.5.17: We are caching XML by serialising using saveXML(), because PHP cannot serialise DOM objects; Some of the XML is variable and is modified per-request. Do you recommend caching then using XPath, or is it better to rebuild the DOM from separate node-groups?

You would need to test your application using the different methods to determine this information. You may find that the default serialization within PHP may allow you to store DOM objects directly into the cache.

4.5.18: How easy is it to introduce memcached to an existing enterprise application instead of inclusion at project design?

In general, it is very easy. In many languages and environments the changes to the application will be just a few lines, first to attempt to read from the cache when loading data and then fall back to the old method, and to update the cache with information once the data has been read.

memcached is designed to be deployed very easily, and you shouldn't require significant architectural changes to your application to use memcached.

4.5.19: Do the memcache UDFs work under 5.1?

Yes.

4.5.20: Is the data inside of memcached secure?

No, there is no security required to access or update the information within a memcached instance, which means that anybody with access to the machine has the ability to read, view and potentially update the information. If you want to keep the data secure, you can encrypt and decrypt the information before storing it. If you want to restrict the users capable of connecting to the server, your only choice is to either disable network access, or use IPTables or similar to restrict access to the memcached ports to a select set of hosts.

4.5.21: Is memcached typically a better solution for improving speed than MySQL Cluster and/or MySQL Proxy?

Both MySQL Cluster and MySQL Proxy still require access to the underlying database to retrieve the information. This implies both a parsing overhead for the statement and, often, disk based access to retrieve the data you have selected.

The advantage of `memcached` is that you can store entire objects or groups of information that may require multiple SQL statements to obtain. Restoring the result of 20 SQL statements formatted into a structure that your application can use directly without requiring any additional processing is always going to be faster than building that structure by loading the rows from a database.

4.5.22: File socket support for `memcached` from the localhost use to the local `memcached` server?

You can use the `-s` option to `memcached` to specify the location of a file socket. This automatically disables network support.

4.5.23: How expensive is it to establish a memcache connection? Should those connections be pooled?

Opening the connection is relatively inexpensive, because there is no security, authentication or other handshake taking place before you can start sending requests and getting results. Most APIs support a persistent connection to a `memcached` instance to reduce the latency. Connection pooling would depend on the API you are using, but if you are communicating directly over TCP/IP, then connection pooling would provide some small performance benefit.

4.5.24: What are the advantages of using UDFs when the get/sets are manageable from within the client code rather than the db?

Sometimes you want to be able to update the information within `memcached` based on a generic database activity, rather than relying on your client code. For example, you may want to update status or counter information in `memcached` through the use of a trigger or stored procedure. For some situations and applications the existing use of a stored procedure for some operations means that updating the value in `memcached` from the database is easier than separately loading and communicating that data to the client just so the client can talk to `memcached`.

In other situations, when you are using a number of different clients and different APIs, you don't want to have to write (and maintain) the code required to update `memcached` in all the environments. Instead, you do this from within the database and the client never gets involved.

4.5.25: How will the data will be handled when the `memcached` server is down?

The behavior is entirely application dependent. Most applications will fall back to loading the data from the database (just as if they were updating the `memcached`) information. If you are using multiple `memcached` servers, you may also want to remove a server from the list to prevent the missing server affecting performance. This is because the client will still attempt to communicate the `memcached` that corresponds to the key you are trying to load.

4.5.26: How are auto-increment columns in the MySQL database coordinated across multiple instances of `memcached`?

They aren't. There is no relationship between MySQL and `memcached` unless your application (or, if you are using the MySQL UDFs for `memcached`, your database definition) creates one.

If you are storing information based on an auto-increment key into multiple instances of `memcached` then the information will only be stored on one of the `memcached` instances anyway. The client uses the key value to determine which `memcached` instance to store the information, it doesn't store the same information across all the instances, as that would be a waste of cache memory.

4.5.27: Is compression available?

Yes. Most of the client APIs support some sort of compression, and some even allow you to specify the threshold at which a value is deemed appropriate for compression during storage.

4.5.28: What speed trade offs is there between `memcached` vs MySQL Query Cache? Where you check `memcached`, and get data from MySQL and put it in `memcached` or just make a query and results are put into MySQL Query Cache.

In general, the time difference between getting data from the MySQL Query Cache and getting the exact same data from `memcached` is very small.

However, the benefit of `memcached` is that you can store any information, including the formatted and processed results of many queries into a single `memcached` key. Even if all the queries that you executed could be retrieved from the Query Cache without having to go to disk, you would still be running multiple queries (with network and other overhead) compared to just one for the `memcached` equivalent. If your application uses objects, or does any kind of processing on the information, with `memcached` you can store the post-processed version, so the data you load is immediately available to be used. With data loaded from the Query Cache, you would still have to do that processing.

In addition to these considerations, keep in mind that keeping data in the MySQL Query Cache is difficult as you have no control over the queries that are stored. This means that a slightly unusual query can temporarily clear a frequently used (and normally cached) query, reducing the effectiveness of your Query Cache. With `memcached` you can specify which objects are stored, when they are stored, and when they should be deleted giving you much more control over the information stored in the cache.

4.5.29: Can we implement different types of `memcached` as different nodes in the same server - so can there be deterministic and non deterministic in the same server?

Yes. You can run multiple instances of `memcached` on a single server, and in your client configuration you choose the list of servers you want to use.

4.5.30: What are best practices for testing an implementation, to ensure that it is an improvement over the MySQL query cache, and to measure the impact of `memcached` configuration changes? And would you recommend keeping the configuration very simple to start?

The best way to test the performance is to start up a `memcached` instance. First, modify your application so that it stores the data just before the data is about to be used or displayed into `memcached`. Since the APIs handle the serialization of the data, it should just be a one line modification to your code. Then, modify the start of the process that would normally load that information from MySQL with the code that requests the data from `memcached`. If the data cannot be loaded from `memcached`, default to the MySQL process.

All of the changes required will probably amount to just a few lines of code. To get the best benefit, make sure you cache entire objects (for example, all the components of a web page, blog post, discussion thread, etc.), rather than using `memcached` as a simple cache of individual rows of MySQL tables. You should see performance benefits almost immediately.

Keeping the configuration very simple at the start, or even over the long term, is very easy with `memcached`. Once you have the basic structure up and running, the only change you may want to make is to add more servers into the list of servers used by your clients. You don't need to manage the `memcached` servers, and there is no complex configuration, just add more servers to the list and let the client API and the `memcached` servers make the decisions.

Chapter 5. MySQL and Virtualization

Using virtualization can be an effective way of better utilizing the hardware of your machine when using MySQL, or to provide improved security or isolation of different instances of MySQL on the same machine. In some circumstances, virtualization may be a suitable solution for scaling out your database environment by enabling you to easily deploy additional instances of a pre-configured MySQL server and application environment to new virtualization hosts.

With any virtualization solution there is often a tradeoff between the flexibility and ease of deployment and performance, or between the potential performance advantage and complexities of effectively configuring multiple instances of MySQL to reside within a single physical host.

Different issues are experienced according to the virtualization environment you are using. Virtualization generally falls into one of the following categories:

- **Native virtualization**, including products like VMware Workstation, Parallels Desktop/Parallels Workstation, Microsoft Virtual PC and VirtualBox, all work by acting as an application that runs within an existing operating system environment. Recent versions can take advantage of the virtualization extensions in the Intel and AMD CPUs to help improve performance.

The application-based solutions have a number of advantages, including the ability to prioritize CPU usage (including multiple CPUs) and easily run multiple virtualized environments simultaneously.

With these solutions, you also have the ability to easily create a virtualized environment that can be packaged and shared among different virtualization hosts. For example, you can create a MySQL environment and configuration that can be deployed multiple times to help extend an existing scalability or HA environment.

The major disadvantage of this type of virtualization environment is the effect of the host on the performance of the virtualization instances. Disk storage is typically provided by using one or more files on the host OS which are then emulated to provide physical disks within the virtual instance. Other resources on the host are similarly shared, including CPU, network interfaces and additional devices (USB). It is also difficult to directly share lower-level components, such as PCI devices and that the ability to take advantage of RAID storage solutions.

- **Paravirtualization (Hypervisor)**, including Xen, Solaris xVM (based on Xen), VMware ESX Server, Windows Server 2008 Hyper-V, and Solaris Logical Domains (LDOM), work by running a specialized version of the host operating system. The host OS then enables slightly modified versions of different operating systems to run within the virtualized environment.

With paravirtualization, the level of performance and the control over the underlying hardware used to support the virtualized environments is higher than native virtualization solutions. For example, using paravirtualization you can dedicate individual CPU cores, RAM, disk drives and even PCI devices to be accessible to individual and specific virtual instances.

For example, within a paravirtualized environment you could dedicate a physical disk drive or subsystem to a particular virtual environment and gain a performance benefit over a typical file-based solution virtual disk.

- **Operating system-level virtualization**, including BSD jails, and Solaris Containers/Zones, offer methods for isolating different instances of an operating system environment while sharing the same hardware environment. Unlike the other virtualization solutions, operating system level virtualization is not normally used to run other operating systems, but instead to provide a level of security isolation and resource control within the core operating environment.

The isolation of these different instances is the key advantage of this type of virtualization. Each virtualized instance sees its environment as if it were completely different system. The solution can be an effective method to provide isolated computing resources for different departments or users, or to provide unique instances for testing and development.

The main reasons for using virtualization, particularly with a database or an application stack that includes a database component, include:

- **Security:** Separate instances of different operating systems running within a single host but with effective isolation from each other. When used with MySQL, you can provide an increased level of security between different instances of each server.
- **Consolidation:** Merging a number of individual systems with a relatively small load onto a single, larger, server. This can help reduce footprint and energy costs, or make more efficient use of a larger machine. Performance is the main issue with this solution as the load of many MySQL databases running in individual virtual instances on a single machine can be considerable.
- **Development/QA/Testing:** By creating different instances of different environments and operating systems you can test your MySQL-based application in different environments.
- **Scalability:** Although using virtualization imposes a performance hit, many virtualization solutions enable you to create a packaged version of an environment, including MySQL and the other application components. By distributing the virtualization environment package to new hosts you can often very quickly scale out by adding new hosts and deploying the virtualized environment.

onment.

The remainder of this chapter looks at common issues with using MySQL in a virtualized environment and tips for using MySQL within different virtualization tools.

For advice on common issues and problems, including performance and configuration issues, when using virtualized instances, see [Section 5.1, “Common Issues with Virtualization”](#).

5.1. Common Issues with Virtualization

There are many issues related to using MySQL within a virtualized environment that are common across the different virtualization types. Most are directly related to the performance or security of the environment in which you are deploying the MySQL server compared to the host on which you are running the virtualization solution.

Before deciding to use virtualization as a solution for your database, ensure that the expected load for the server and the expected performance when run in a virtualized environment meet your needs and requirements.

To help you determine the issues and some of the potential solutions, use the following sections:

- For general performance issues, problems and the probable causes, see [Section 5.1.1, “Virtualization Performance Issues”](#).
- Disk and storage concerns directly affect database storage because most database access is limited by the I/O bandwidth. For some examples and issues, see [Section 5.1.2, “Virtualization Storage Issues”](#).
- Issues related to network configuration and performance may need more careful planning, especially if you are using network-specific technologies such as MySQL replication. For further examples and details, see [Section 5.1.3, “Virtualization Networking Issues”](#).

5.1.1. Virtualization Performance Issues

Often the biggest consideration is the performance of a virtualized environment once hosted. In most cases, the virtualized environment involves some level of emulation of one or more of the hardware interfaces (CPU, network or disk) of the host environment. The effect is to reduce the effective performance of the virtualized environment compared to running an application natively on the host.

Some core resourcing issues to be aware of include:

- Using virtualization does not reduce the amount of CPU required to support a particular application or environment. If your application stack requires 2GB of RAM on an individual machine, the same RAM requirement applies within your virtualized environment. The additional overhead of the virtualization layer and host operating system or environment often mean that you need 2.5GB or 3GB of RAM to run the same application within the virtualized environment.

Configure your virtualization environment with the correct RAM allocation according to your applications needs, and not to maximize the number of virtualized environments that you can execute within the virtualization host.

- Virtualization of the CPU resources is more complex. If your MySQL database and application stack do not have a high CPU load, then consolidating multiple environments onto a single host is often more efficient. Keep in mind that at peak times your application and database CPU requirement may need to grow beyond your default allocation.

With some virtualization environments (Xen, Solaris Containers, Solaris LDOMs) you can dedicate CPU or core to a virtual instance. Use this functionality to improve performance for database or application loads that have a high constant CPU requirement, as the performance benefit outweighs the flexibility of dynamic allocation of the CPU resources.

- Contention of resources within the host should be taken into account. In a system with high CPU loads, even when dedicating RAM and CPU resources, the I/O channels and interfaces to storage and networking resources may exceed the capacity of the host. Solutions such as Xen and Solaris LDOMs dedicate specific resources to individual virtual instances, but this does not eliminate the effects of the overall load on the host.
- If your database application is time sensitive, including logging and real-time database applications, or you are using MySQL Cluster, then the effects of virtualization may severely reduce the performance of your application. Because of the way the virtualized instances are executed and shared between CPUs and the effects of load on other resources, the response times for your database or application may be much higher than normal. This is especially true if you are running a large number of virtualized instances on a single host.
- Be aware of the limitation of using a single host to run multiple virtualized instances. In the event of a machine or component failure, the problem affects more than just one database instance. For example, a failure in a storage device could bring down

all your virtualized instances. Using a RAID solution that supports fault tolerance (RAID levels 1,3,4,5 or 6) helps protect you from the effects of this.

5.1.2. Virtualization Storage Issues

Due to the random I/O nature of any database solution, running MySQL within a virtualized environment places a heavy load on the storage solution you are using. To help keep the performance of your virtualized solution at the highest level, use the following notes to help configure your systems.

- Some virtualization solutions permit you to use a physical disk directly within your virtual host as if it were a local disk. Use this whenever possible to ensure that disk contention issues do not affect the performance of your virtual environment.

When running multiple virtual machines, use an individual disk for each virtual instance. Using a single disk and multiple partitions, with each partition dedicated to a virtual host, leads to the same contention issues.

- If you are using standard file-based storage for your virtualized disks:
 - File-based storage is subject to fragmentation on the host disk. To prevent fragmentation, create a fixed-size disk (that is, one where the entire space for the disk file is preallocated) instead of a dynamic disk that grows with usage. Be prepared to defragment the disk hosting the files at regular intervals, to reduce the fragmentation.
 - Use separate disk files for the operating system and database disks, and try to avoid partitioning a disk file as this increases the contention within the file.
 - Use a high-performance disk solution, such as RAID or SAN, to store the disk files for your virtualized environments. This improves the performance of what is essentially a large single file on a physical device.
 - When running a number of different virtualized environments within a single host, do not use the same physical host drive for multiple virtual disks. Instead, spread the virtual disks among multiple physical disks. Even when using a RAID device, be aware that each virtual host is equivalent to increasing the load linearly on the host RAID device.

5.1.3. Virtualization Networking Issues

When running multiple virtual machines on a host, be aware of the networking implications of each virtualized instance. If your host machine has only one network card, then you share the networking throughput for all of your machines through only one card, and this can severely limit the performance of your virtual environments.

If possible, use multiple network cards to support your virtualized instances. Depending on the expected load of each instance, dedicate or spread the allocation of the virtual network devices across these physical devices to ensure that you do not reach saturation.

If you are using packaged virtual machines as the basis for deployment of your MySQL database solution, make sure that the network interfaces are correctly reconfigured. Some solutions duplicate the hardware MAC address, which causes problems when you start up additional instances of the same virtualized environment.

5.2. Using MySQL within an Amazon EC2 Instance

The Amazon Elastic Compute Cloud (EC2) service provides virtual servers that you can build and deploy to run a variety of different applications and services, including MySQL. The EC2 service is based around the Xen framework, supporting x86, Linux based, platforms with individual instances of a virtual machine referred to as an Amazon Machine Image (AMI). You have complete (root) access to the AMI instance that you create, enabling you to configure and install your AMI in any way you choose.

To use EC2, you create an AMI based on the configuration and applications that you want to use and upload the AMI to the Amazon Simple Storage Service (S3). From the S3 resource, you can deploy one or more copies of the AMI to run as an instance within the EC2 environment. The EC2 environment provides management and control of the instance and contextual information about the instance while it is running.

Because you can create and control the AMI, the configuration, and the applications, you can deploy and create any environment you choose. This includes a basic MySQL server in addition to more extensive replication, HA and scalability scenarios that enable you to take advantage of the EC2 environment, and the ability to deploy additional instances as the demand for your MySQL services and applications grow.

To aid the deployment and distribution of work, three different Amazon EC2 instances are available, small (identified as `m1.small`), large (`m1.large`) and extra large (`m1.xlarge`). The different types provide different levels of computing power measured in EC2 computer units (ECU). A summary of the different instance configurations is shown here.

	Small	Large	Extra Large
Platform	32-bit	64-bit	64-bit
CPU cores	1	2	4
ECUs	1	4	8
RAM	1.7GB	7.5GB	15GB
Storage	150GB	840GB	1680GB
I/O Performance	Medium	High	High

The typical model for deploying and using MySQL within the EC2 environment is to create a basic AMI that you can use to hold your database data and application. Once the basic environment for your database and application has been created you can then choose to deploy the AMI to a suitable instance. Here the flexibility of having an AMI that can be re-deployed from the small to the large or extra large EC2 instance makes it easy to upgrade the hardware environment without rebuilding your application or database stack.

To get started with MySQL on EC2, including information on how to set up and install MySQL within an EC2 installation and how to port and migrate your data to the running instance, see [Section 5.2.1, “Setting Up MySQL on an EC2 AMI”](#).

For tips and advice on how to create a scalable EC2 environment using MySQL, including guides on setting up replication, see [Section 5.2.3, “Deploying a MySQL Database Using EC2”](#).

5.2.1. Setting Up MySQL on an EC2 AMI

There are many different ways of setting up an EC2 AMI with MySQL, including using any of the pre-configured AMIs supplied by Amazon.

The default *Getting Started* AMI provided by Amazon uses Fedora Core 4, and you can install MySQL by using `yum`:

```
shell> yum install mysql
```

This installs both the MySQL server and the Perl DBD::mysql driver for the Perl DBI API.

Alternatively, you can use one of the AMIs that include MySQL within the standard installation.

Finally, you can also install a standard version of MySQL downloaded from the MySQL Web site. The installation process and instructions are identical to any other installation of MySQL on Linux. See [Installing and Upgrading MySQL](#).

The standard configuration for MySQL places the data files in the default location, `/var/lib/mysql`. The default data directory on an EC2 instance is `/mnt` (although on the large and extra large instance you can alter this configuration). You must edit `/etc/my.cnf` to set the `datadir` option to point to the larger storage area.

Important

The first time you use the main storage location within an EC2 instance it needs to be initialized. The initialization process starts automatically the first time you write to the device. You can start using the device right away, but the write performance of the new device is significantly lower on the initial writes until the initialization process has finished.

To avoid this problem when setting up a new instance, you should start the initialization process before populating your MySQL database. One way to do this is to use `dd` to write to the file system:

```
root-shell> dd if=/dev/zero of=initialize bs=1024M count=50
```

The preceding creates a 50GB on the file system and starts the initialization process. Delete the file once the process has finished.

The initialization process can be time-consuming. On the small instance, initialization takes between two and three hours. For the large and extra large drives, the initialization can be 10 or 20 hours, respectively.

In addition to configuring the correct storage location for your MySQL data files, also consider setting the following other settings in your instance before you save the instance configuration for deployment:

- Set the MySQL server ID, so that when you use it for replication, the ID information is set correctly.
- Enabling binary logging, so that replication can be initialized without starting and stopping the server.

- Set the caching and memory parameters for your storage engines. There are no limitations or restrictions on what storage engines you use in your EC2 environment. Choose a configuration, possibly using one of the standard configurations provided with MySQL appropriate for the instance on which you expect to deploy. The large and extra large instances have RAM that can be dedicated to caching. Be aware that if you choose to install [memcached](#) on the servers as part of your application stack you must ensure there is enough memory for both MySQL and [memcached](#).

Once you have configured your AMI with MySQL and the rest of your application stack, save the AMI so that you can deploy and reuse the instance.

Once you have your application stack configured in an AMI, populating your MySQL database with data should be performed by creating a dump of your database using [mysqldump](#), transferring the dump to the EC2 instance, and then reloading the information into the EC2 instance database.

Before using your instance with your application in a production situation, be aware of the limitations of the EC2 instance environment. See [Section 5.2.2, “EC2 Instance Limitations”](#). To begin using your MySQL AMI, consult the notes on deployment. See [Section 5.2.3, “Deploying a MySQL Database Using EC2”](#).

5.2.2. EC2 Instance Limitations

Be aware of the following limitations of the EC2 instances before deploying your applications. Although these shouldn't affect your ability to deploy within the Amazon EC2 environment, they may alter the way you setup and configure your environment to support your application.

- Data stored within instances is not persistent. If you create an instance and populate the instance with data, then the data only remains in place while the machine is running, and does not survive a reboot. If you shut down the instance, any data it contained is lost.

To ensure that you do not lose information, take regular backups using [mysqldump](#). If the data being stored is critical, consider using replication to keep a “live” backup of your data in the event of a failure. When creating a backup, write the data to the Amazon S3 service to avoid the transfer charges applied when copying data offsite.

- EC2 instances are not persistent. If the hardware on which an instance is running fails, the instance is shut down. This can lead to loss of data or service.
- If you want to use replication with your EC2 instances to a non-EC2 environment, be aware of the transfer costs to and from the EC2 service. Data transfer between different EC2 instances is free, so using replication within the EC2 environment does not incur additional charges.
- Certain HA features are either not directly supported, or have limiting factors or problems that may reduce their utility. For example, using DRBD or MySQL Cluster may not work. The default storage configuration is also not redundant. You can use software-based RAID to improve redundancy, but this implies a further performance hit.

5.2.3. Deploying a MySQL Database Using EC2

Because you cannot guarantee the uptime and availability of your EC2 instances, when deploying MySQL within the EC2 environment, use an approach that enables you to easily distribute work among your EC2 instances. There are a number of ways of doing this. Using sharding techniques, where you split the application across multiple servers dedicating specific blocks of your dataset and users to different servers is an effective way of doing this. As a general rule, it is easier to create more EC2 instances to support more users than to upgrade the instance to a larger machine.

The EC2 architecture works best when you treat the EC2 instances as temporary, cache-based solutions, rather than as a long-term, high availability solution. In addition to using multiple machines, take advantage of other services, such as [memcached](#) to provide additional caching for your application to help reduce the load on the MySQL server so that it can concentrate on writes. On the large and extra large instances within EC2, the RAM available can provide a large memory cache for data.

Most types of scale-out topology that you would use with your own hardware can be used and applied within the EC2 environment. However, use the limitations and advice already given to ensure that any potential failures do not lose you any data. Also, because the relative power of each EC2 instance is so low, be prepared to alter your application to use sharding and add further EC2 instances to improve the performance of your application.

For example, take the typical scale-out environment shown following, where a single master replicates to one or more slaves (three in this example), with a web server running on each replication slave.

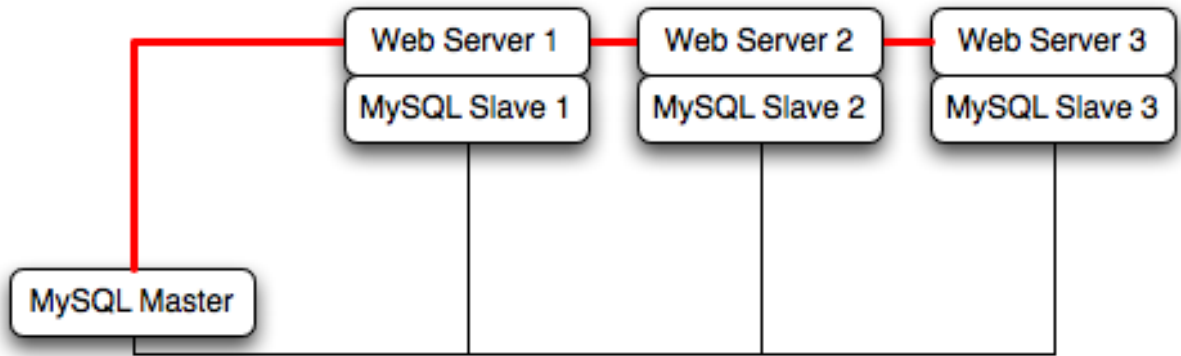

You can reproduce this structure completely within the EC2 environment, using an EC2 instance for the master, and one instance for each of the web and MySQL slave servers.

Note

Within the EC2 environment, internal (private) IP addresses used by the EC2 instances are constant. Always use these internal addresses and names when communicating between instances. Only use public IP addresses when communicating with the outside world - for example, when publicizing your application.

To ensure reliability of your database, add at least one replication slave dedicated to providing an active backup and storage to the Amazon S3 facility. You can see an example of this in the following topology.

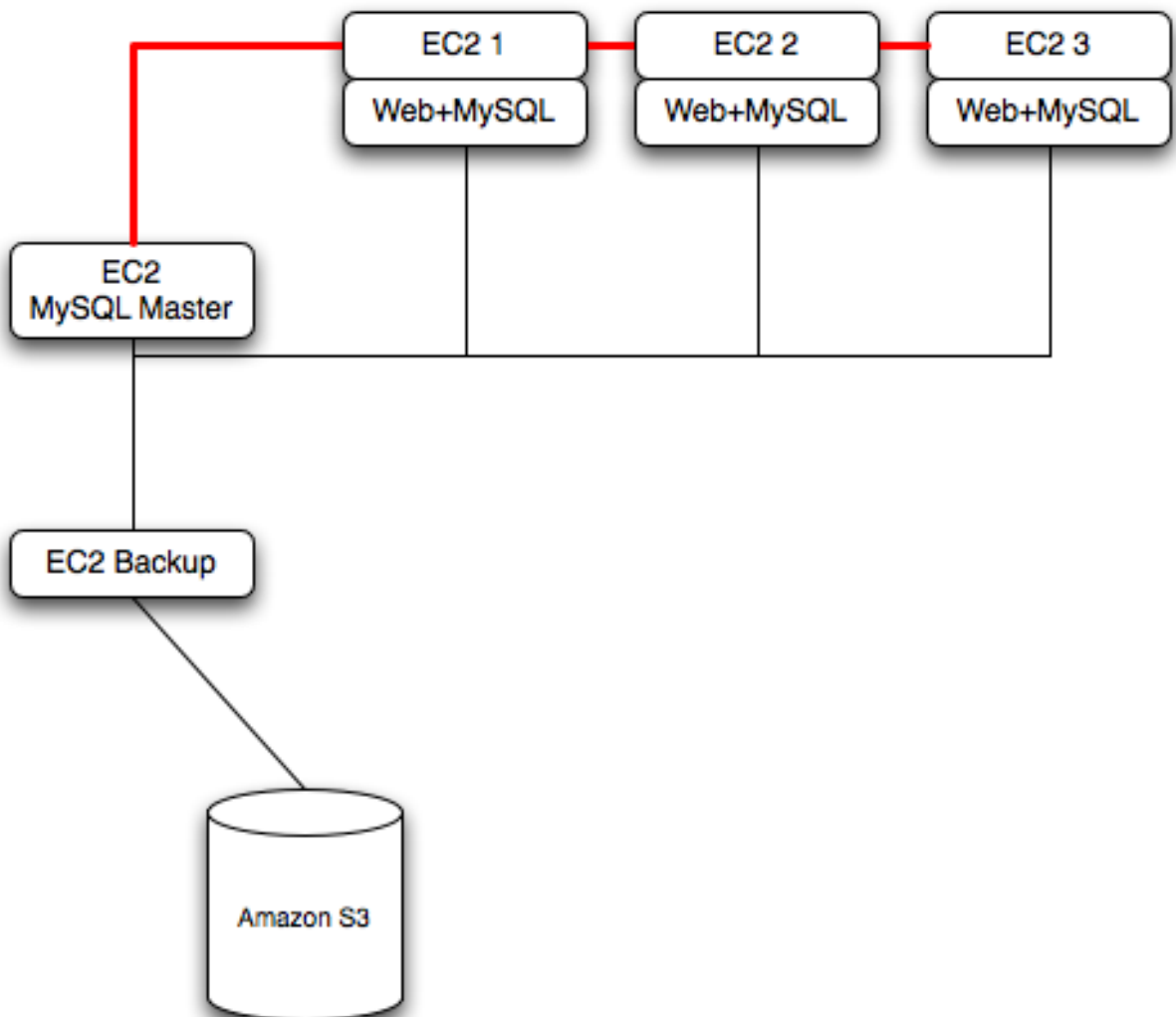

Using `memcached` within your EC2 instances should provide better performance. The large and extra large instances have a significant amount of RAM. To use `memcached` in your application, when loading information from the database, first check whether the item exists in the cache. If the data you are looking for exists in the cache, use it. If not, reload the data from the database and populate the cache.

Sharding divides up data in your entire database by allocating individual machines or machine groups to provide a unique set of data according to an appropriate group. For example, you might put all users with a surname ending in the letters A-D onto a single server. When a user connects to the application and their surname is known, queries can be redirected to the appropriate MySQL server.

When using sharding with EC2, separate the web server and MySQL server into separate EC2 instances, and then apply the sharding decision logic into your application. Once you know which MySQL server you should be using for accessing the data you then distribute queries to the appropriate server. You can see a sample of this in the following illustration.

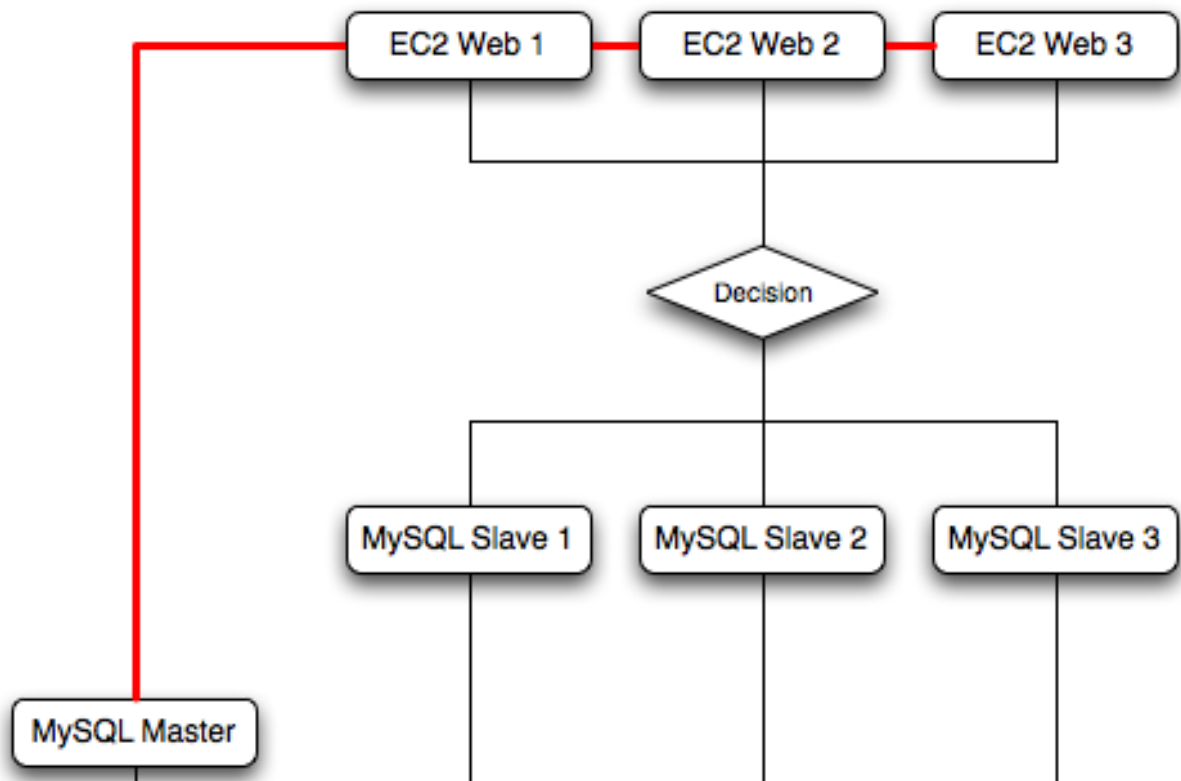

Warning

With sharding and EC2, be careful that the potential for failure of an instance does not affect your application. If the EC2 instance that provides the MySQL server for a particular shard fails, then all of the data on that shard becomes unavailable.

5.3. Virtualization Resources

For more information on virtualization, see the following links:

- [MySQL Virtualization Forum](#)
- [Amazon Elastic Compute Cloud \(Amazon EC2\)](#)
- <http://www.mysql.com/products/enterprise/cloud.html>
- <http://www.mysql.com/products/enterprise/ec2.html>

Chapter 6. MySQL Proxy

The MySQL Proxy is an application that communicates over the network using the MySQL network protocol and provides communication between one or more MySQL servers and one or more MySQL clients. In the most basic configuration, MySQL Proxy simply interposes itself between the server and clients, passing queries from the clients to the MySQL Server and returning the responses from the MySQL Server to the appropriate client.

Because MySQL Proxy uses the MySQL network protocol, it can be used without modification with any MySQL-compatible client that uses the protocol. This includes the `mysql` command-line client, any clients that uses the MySQL client libraries, and any connector that supports the MySQL network protocol.

In addition to the basic pass-through configuration, the MySQL Proxy is also capable of monitoring and altering the communication between the client and the server. Query interception enables you to add profiling, and interception of the exchanges is scriptable using the Lua scripting language.

By intercepting the queries from the client, the proxy can insert additional queries into the list of queries sent to the server, and remove the additional results when they are returned by the server. Using this functionality you can return the results from the original query to the client while adding informational statements to each query, for example, to monitor their execution time or progress, and separately log the results.

The proxy enables you to perform additional monitoring, filtering, or manipulation of queries without requiring you to make any modifications to the client and without the client even being aware that it is communicating with anything but a genuine MySQL server.

This documentation covers MySQL Proxy 0.8.0.

Warning

MySQL Proxy is currently an Alpha release and should not be used within production environments.

Important

MySQL Proxy is compatible with MySQL 5.0 or later. Testing has not been performed with Version 4.1. Please provide feedback on your experiences using the [MySQL Proxy Forum](#).

6.1. MySQL Proxy Supported Platforms

MySQL Proxy is currently available as a precompiled binary for the following platforms:

- Linux (including RedHat, Fedora, Debian, SuSE) and derivatives
- Mac OS X
- FreeBSD
- IBM AIX
- Sun Solaris
- Microsoft Windows (including Microsoft Windows XP, Microsoft Windows Vista, Microsoft Windows Server 2003, Microsoft Windows Server 2008)

Note

You must have the .NET Framework 1.1 or higher installed.

Other Unix/Linux platforms not listed should be compatible by using the source package and building MySQL Proxy locally.

System requirements for the MySQL Proxy application are the same as the main MySQL server. Currently MySQL Proxy is compatible only with MySQL 5.0.1 and later. MySQL Proxy is provided as a standalone, statically linked binary. You need not have MySQL or Lua installed.

6.2. Installing MySQL Proxy

You have three choices for installing MySQL Proxy:

- Precompiled binaries are available for a number of different platforms. See [Section 6.2.1, “Installing MySQL Proxy from a Binary Distribution”](#).
- You can install from the source code if you want to build on an environment not supported by the binary distributions. See [Section 6.2.2, “Installing MySQL Proxy from a Source Distribution”](#).
- The latest version of the MySQL Proxy source code is available through a development repository is the best way to stay up to date with the latest fixes and revisions. See [Section 6.2.3, “Installing MySQL Proxy from the Bazaar Repository”](#).

6.2.1. Installing MySQL Proxy from a Binary Distribution

If you download a binary package, you must extract and copy the package contents to your desired installation directory. The package contains files required by MySQL Proxy, including additional Lua scripts and other components required for execution.

To install, unpack the archive into the desired directory, then modify your `PATH` environment variable so that you can use the `mysql-proxy` command directly:

```
shell> cd /usr/local
shell> tar zxf mysql-proxy-0.7.2-osx10.5.tar.gz
shell> PATH=$PATH:/usr/local/mysql-proxy-0.7.2-osx10.5-x86/sbin
```

If you want to update the path globally on a system, you may need administrator privileges to modify the appropriate `/etc/profile`, `/etc/bashrc`, or other system configuration file.

On Windows, you can update the `PATH` environment variable using this procedure:

1. On the Windows desktop, right-click the My Computer icon, and select Properties.
2. Next select the Advanced tab from the `SYSTEM PROPERTIES` menu that appears, and click the ENVIRONMENT VARIABLES button.
3. Under `SYSTEM VARIABLES`, select Path, then click the EDIT button. The `EDIT SYSTEM VARIABLE` dialogue should appear.

6.2.2. Installing MySQL Proxy from a Source Distribution

If you download a source package, you must compile the MySQL Proxy before using it. A build from source requires that the following prerequisite components be installed:

- `libevent` 1.x or higher (1.3b or later is preferred)
- `lua` 5.1.x or higher
- `glib2` 2.6.0 or higher
- `pkg-config`
- `libtool` 1.5 or higher
- MySQL 5.0.x or higher developer files

Note

On some operating systems you may need to manually build the required components to get the latest version. If you have trouble compiling MySQL Proxy, consider using a binary distributions instead.

After you have verified that the prerequisite components are installed, configure and build MySQL Proxy:

```
shell> tar zxf mysql-proxy-0.7.2.tar.gz
shell> cd mysql-proxy-0.7.2
shell> ./configure
shell> make
```

If you want to test the build, use the `check` target to `make`:

```
shell> make check
```

The tests try to connect to `localhost` using the `root` user. If you need to provide a password, set the `MYSQL_PASSWORD` environment variable:

```
shell> MYSQL_PASSWORD=root_pwd make check
```

You can install using the `install` target:

```
shell> make install
```

By default, `mysql-proxy` is installed into `/usr/local/sbin/mysql-proxy`. The Lua example scripts are installed into `/usr/local/share`.

6.2.3. Installing MySQL Proxy from the Bazaar Repository

The MySQL Proxy source is available through a public Bazaar repository and is the quickest way to get the latest releases and fixes.

A build from the Bazaar repository requires that the following prerequisite components be installed:

- Bazaar 1.10.0 or later
- `libtool` 1.5 or higher
- `autoconf` 2.56 or higher
- `automake` 1.10 or higher
- `libevent` 1.x or higher (1.3b or later is preferred)
- `lua` 5.1.x or higher
- `glib2` 2.4.0 or higher
- `pkg-config`
- MySQL 5.0.x or higher developer files

The `mysql-proxy` source is hosted on Launchpad. To check out a local copy of the Bazaar repository, use `bzr`:

```
shell> bzr branch lp:mysql-proxy
```

The preceding command downloads a complete version of the Bazaar repository for `mysql-proxy`. The main source files are located within the `trunk` subdirectory. The configuration scripts must be generated before you can configure and build `mysql-proxy`. The `autogen.sh` script generates the required configuration scripts for you:

```
shell> sh ./autogen.sh
```

The `autogen.sh` script creates the standard `configure` script, which you then use to configure and build with `make`:

```
shell> ./configure
shell> make
shell> make install
```

If you want to create a standalone source distribution, identical to the source distribution available for download, use this command:

```
shell> make distcheck
```

The preceding command creates the file `mysql-proxy-0.7.2.tar.gz` (with the corresponding current version) within the current directory.

6.2.4. Setting Up MySQL Proxy as a Windows Service

The MySQL distribution on Windows includes the `mysql-proxy-svc.exe` command that enables a MySQL Proxy instance to be managed by the Windows service control manager. This enables you to control the service without separately running the MySQL Proxy application, and allows for automatically starting and stopping the MySQL Proxy service during boot, reboot and

shutdown.

To set up a MySQL Proxy service, you must use the `sc` command to create a new service using the MySQL Proxy service command. Specify the MySQL Proxy options on the `sc` command line, and identify the service with a unique name. For example, to configure a new MySQL Proxy instance that will automatically start when your system boots, redirecting queries to the local MySQL server:

```
C:\> sc create "Proxy" DisplayName= "MySQL Proxy" start= "auto" »
binPath= "C:\Program Files\MySQL\mysql-proxy-0.8.0\bin\mysql-proxy-svc.exe »
--proxy-backend-addresses=127.0.0.1:3306"
```

Note

The space following the equal sign after each property is required; failure to include it results in an error.

The preceding command creates a new service called `Proxy`. You can start and stop the service using the `net start|stop` command with the service name. The service is not automatically started after it has been created. To start the service:

```
C:\> net start proxy
The MySQL Proxy service is starting.
The MySQL Proxy service was started successfully.
```

You can specify any additional command-line options you need to the `sc` command. You can also set up multiple MySQL Proxy services on the same machine (providing they are configured to listen on different ports and/or IP addresses).

You can delete a service that you have created:

```
C:\> sc delete proxy
```

For more information on creating services using `sc`, see [How to create a Windows service by using Sc.exe](#).

6.3. MySQL Proxy Command Options

To start MySQL Proxy, you can run it directly from the command line:

```
shell> mysql-proxy
```

However, for most situations you will want to specify at the very least the host name or address and the port number of the backend MySQL server to which the MySQL Proxy should pass queries.

You can specify options to `mysql-proxy` either on the command line, or by using a configuration file and the `--defaults-file` command-line option to specify the file location.

If you use a configuration file, it should be formatted as follows:

- Options must be specified within a `[mysql-proxy]` configuration group. For example:

```
[mysql-proxy]
admin-address = host:port
```

- All configuration options should be specified in the form of a configuration name and the value you want to set.
- For options that are a simple toggle on the command line (for example, `--proxy-skip-profiling`), you must use `true` or `false`. For example, the following is invalid:

```
[mysql-proxy]
proxy-skip-profiling
```

But this is valid:

```
[mysql-proxy]
proxy-skip-profiling = true
```

- The configuration file should have permissions of `0660` (readable and writable by user and group, no access for others).

Failure to adhere to any of these requirements causes `mysql-proxy` to generate an error during startup.

The following tables list the supported configuration file and command-line options.

Table 6.1. `mysql-proxy` Help Options

Format	Option File	Description	Introduc- tion	Deprec- ated	Removed
<code>--help</code>	<code>help</code>	Show help options			
<code>--help-admin</code>	<code>help-admin</code>	Show admin module options			
<code>--help-all</code>	<code>help-all</code>	Show all help options			
<code>--help-proxy</code>	<code>help-proxy</code>	Show proxy module options			

Table 6.2. `mysql-proxy` Admin Options

Format	Option File	Description	Introduc- tion	Deprec- ated	Removed
<code>- -ad- min-ad- dress=host:port</code>	<code>admin-ad- dress=host:port</code>	The admin module listening host and port			
<code>- -ad- min- lua- script=file_name</code>	<code>admin- lua- script=file_name</code>	Script to execute by the admin module			
<code>- -ad- min-pass- word=password</code>	<code>admin-pass- word=password</code>	Authentication password for admin module			
<code>- -ad- min-user- name=user_name</code>	<code>admin-user- name=user_name</code>	Authentication user name for admin module			
<code>- - proxy-ad- dress=host:port</code>	<code>proxy-ad- dress=host:port</code>	The listening proxy server host and port			

Table 6.3. `mysql-proxy` Proxy Options

Format	Option File	Description	Introduc- tion	Deprec- ated	Removed
<code>--no-proxy</code>	<code>no-proxy</code>	Do not start the proxy module			
<code>- - proxy- backend-ad- dresses=host:port</code>	<code>proxy- backend-ad- dresses=host:port</code>	The MySQL server host and port			
<code>- - proxy- fix-bug-25371</code>	<code>proxy- fix-bug-25371</code>	Enable the fix for Bug#25371 for older libmysql versions			0.8.1
<code>- - proxy- lua- script=file_name</code>	<code>proxy- lua- script=file_name</code>	Filename for Lua script for proxy operations			
<code>- - proxy- pool- no-change-user</code>	<code>proxy- pool- no-change-user</code>	Do not use the protocol <code>CHANGE_USER</code> command to reset the connection when coming from the connection pool			

Format	Option File	Description	Introduc- tion	Deprec- ated	Removed
- - proxy- read- only- backend-ad- dresses=host:port	proxy- read- only- backend-ad- dresses=host:port	The MySQL server host and port (read only)			
- - proxy- skip-profiling	proxy- skip-profiling	Disable query profiling			

Table 6.4. `mysql-proxy` Applications Options

Format	Option File	Description	Introduc- tion	Deprec- ated	Removed
- - basedir=dir_name	basedir=dir_name	The base directory prefix for paths in the configura- tion			
--daemon	daemon	Start in daemon mode			
- -de- faults- file=file_name		The configuration file to use			
- - event- threads=count	event- threads=count	The number of event-handling threads			
--keepalive	keepalive	Try to restart the proxy if a crash occurs			
- - log-back- trace-on-crash	log-back- trace-on-crash	Try to invoke the debugger and generate a back- trace on crash			
- - log- file=file_name	log- file=file_name	The file where error messages are logged			
--log-level=level	log-level=level	The logging level			
--log-use-syslog	log-use-syslog	Log errors to syslog			
- - lua- cpath=dir_name	lua- cpath=dir_name	Set the LUA_CPATH			
- - lua- path=dir_name	lua- path=dir_name	Set the LUA_PATH			
- - max- open-files=count	max- open-files=count	The maximum number of open files to support			
- - pid- file=file_name	pid- file=file_name	File in which to store the process ID			
- -plu- gin-dir=dir_name	plugin- dir=dir_name	Directory containing plugin files			
-	plugins=plugin,...	List of plugins to load			

Format	Option File	Description	Introduc- tion	Deprec- ated	Removed
<code>-plugins=plugin,...</code>					
<code>--user=user_name</code>	<code>user=user_name</code>	The user to use when running mysql-proxy			
<code>--version</code>	<code>version</code>	Show version information			

Except as noted in the following details, all of the options can be used within the configuration file by supplying the option and the corresponding value. For example:

```
[mysql-proxy]
log-file = /var/log/mysql-proxy.log
log-level = message
```

- `--help, -h`

Command-Line Format	<code>--help</code>
	<code>-h</code>
Option-File Format	<code>help</code>

Show available help options.

- `--help-admin`

Command-Line Format	<code>--help-admin</code>
Option-File Format	<code>help-admin</code>

Show options for the admin module.

- `--help-all`

Command-Line Format	<code>--help-all</code>
Option-File Format	<code>help-all</code>

Show all help options.

- `--help-proxy`

Command-Line Format	<code>--help-proxy</code>
Option-File Format	<code>help-proxy</code>

Show options for the proxy module.

- `--admin-address=host:port`

Command-Line Format	<code>--admin-address=host:port</code>	
Option-File Format	<code>admin-address=host:port</code>	
	Permitted Values	
	Type	<code>string</code>
	Default	<code>:4041</code>

The host name (or IP address) and port for the administration port. The default is `localhost:4041`.

- `--admin-lua-script=file_name`

Command-Line Format	<code>--admin-lua-script=file_name</code>
Option-File Format	<code>admin-lua-script=file_name</code>

	Permitted Values	
	Type	file name
	Default	

The script to use for the proxy administration module.

- `--admin-password=password`

Command-Line Format	<code>--admin-password=password</code>	
Option-File Format	<code>admin-password=password</code>	
	Permitted Values	
	Type	string
	Default	

The password to use to authenticate users wanting to connect to the MySQL Proxy administration module. This module uses the MySQL protocol to request a user name and password for connections.

- `--admin-username=user_name`

Command-Line Format	<code>--admin-username=user_name</code>	
Option-File Format	<code>admin-username=user_name</code>	
	Permitted Values	
	Type	string
	Default	root

The user name to use to authenticate users wanting to connect to the MySQL Proxy administration module. This module uses the MySQL protocol to request a user name and password for connections. The default user name is `root`.

- `--basedir=dir_name`

Command-Line Format	<code>--basedir=dir_name</code>	
Option-File Format	<code>basedir=dir_name</code>	
	Permitted Values	
	Type	directory name

The base directory to use as a prefix for all other file name configuration options. The base name should be an absolute (not relative) directory. If you specify a relative directory, `mysql-proxy` generates an error during startup.

- `--daemon`

Command-Line Format	<code>--daemon</code>	
Option-File Format	<code>daemon</code>	

Starts the proxy in daemon mode.

- `--defaults-file=file_name`

Command-Line Format	<code>--defaults-file=file_name</code>	
----------------------------	--	--

The file to read for configuration options. If not specified, MySQL Proxy takes options only from the command line.

- `--event-threads=count`

Command-Line Format	<code>--event-threads=count</code>	
Option-File Format	<code>event-threads=count</code>	

	Permitted Values	
	Type	numeric
	Default	1

The number of event threads to reserve to handle incoming requests.

- `--keepalive`

Command-Line Format	<code>--keepalive</code>
Option-File Format	<code>keepalive</code>

Create a process surrounding the main `mysql-proxy` process that attempts to restart the main `mysql-proxy` process in the event of a crash or other failure.

Note

The `--keepalive` option is not available on Microsoft Windows. When running as a service, `mysql-proxy` automatically restarts.

- `--log-backtrace-on-crash`

Command-Line Format	<code>--log-backtrace-on-crash</code>
Option-File Format	<code>log-backtrace-on-crash</code>

Log a backtrace to the error log and try to initialize the debugger in the event of a failure.

- `--log-file=file_name`

Command-Line Format	<code>--log-file=file_name</code>	
Option-File Format	<code>log-file=file_name</code>	
	Permitted Values	
	Type	file name

The file to use to record log information. If this option is not given, `mysql-proxy` logs to the standard error output.

- `--log-level=level`

Command-Line Format	<code>--log-level=level</code>	
Option-File Format	<code>log-level=level</code>	
	Permitted Values	
	Type	enumeration
	Valid Values	<code>error, warning, info, message, debug</code>

The log level to use when outputting error messages. Messages with that level (or lower) are output. For example, `message` level also outputs message with `info`, `warning`, and `error` levels.

- `--log-use-syslog`

Command-Line Format	<code>--log-use-syslog</code>
Option-File Format	<code>log-use-syslog</code>

Log errors to the syslog (Unix/Linux only).

- `--lua-cpath=dir_name`

Command-Line Format	<code>--lua-cpath=dir_name</code>	
Option-File Format	<code>lua-cpath=dir_name</code>	
	Permitted Values	
	Type	<code>directory name</code>

The `LUA_CPATH` to use when loading compiled modules or libraries for Lua scripts.

- `--lua-path=dir_name`

Command-Line Format	<code>--lua-path=dir_name</code>	
Option-File Format	<code>lua-path=dir_name</code>	
	Permitted Values	
	Type	<code>directory name</code>

The `LUA_CPATH` to use when loading modules for Lua.

- `--max-open-files=count`

Command-Line Format	<code>--max-open-files=count</code>	
Option-File Format	<code>max-open-files=count</code>	
	Permitted Values	
	Type	<code>numeric</code>

The maximum number of open files and sockets supported by the `mysql-proxy` process. You may need to increase this with certain scripts.

- `--no-proxy`

Command-Line Format	<code>--no-proxy</code>	
Option-File Format	<code>no-proxy</code>	

Disable the proxy module.

- `--plugin-dir=dir_name`

Command-Line Format	<code>--plugin-dir=dir_name</code>	
Option-File Format	<code>plugin-dir=dir_name</code>	
	Permitted Values	
	Type	<code>directory name</code>

The directory to use when loading plugins for `mysql-proxy`.

- `--plugins=plugin,...`

Command-Line Format	<code>--plugins=plugin,...</code>	
Option-File Format	<code>plugins=plugin,...</code>	
	Permitted Values	
	Type	<code>string</code>

A comma-separated list of plugins to load.

- `--proxy-address=host:port, -P host:port`

Command-Line Format	<code>--proxy-address=host:port</code>	
----------------------------	--	--

	<code>-P host:port</code>
Option-File Format	<code>proxy-address=host:port</code>
	Permitted Values
	Type <code>string</code>
	Default <code>:4040</code>

The listening host name (or IP address) and port of the proxy server. The default is `:4040` (all IPs on port 4040).

- `--proxy-read-only-backend-addresses=host:port, -r host:port`

Command-Line Format	<code>--proxy-read-only-backend-addresses=host:port</code>
	<code>-r host:port</code>
Option-File Format	<code>proxy-read-only-backend-addresses=host:port</code>
	Permitted Values
	Type <code>string</code>

The listening host name (or IP address) and port of the proxy server for read-only connections. The default is for this information not to be set.

Note

Setting this value only configures the servers within the corresponding internal structure (see `proxy.global.backends`). You can determine the backend type by checking the `type` field for each connection.

You should therefore only use this option in combination with a script designed to make use of the different backend types.

When using this option on the command line, you can specify the option and the server multiple times to specify multiple backends. For example:

```
shell> mysql-proxy --proxy-read-only-backend-addresses 192.168.0.1:3306 --proxy-read-only-backend-addresses 192.168.0.2:3306
```

When using the option within the configuration file, you should separate multiple servers with a comma. The equivalent of the preceding example would be:

```
...
proxy-read-only-backend-addresses = 192.168.0.1:3306, 192.168.0.2:3306
```

- `--proxy-backend-addresses=host:port, -b host:port`

Command-Line Format	<code>--proxy-backend-addresses=host:port</code>
	<code>-b host:port</code>
Option-File Format	<code>proxy-backend-addresses=host:port</code>
	Permitted Values
	Type <code>string</code>
	Default <code>127.0.0.1:3306</code>

The host name (or IP address) and port of the MySQL server to connect to. You can specify multiple backend servers by supplying multiple options. Clients are connected to each backend server in round-robin fashion. For example, if you specify two servers A and B, the first client connection will go to server A; the second client connection to server B and the third client connection to server A.

When using this option on the command line, you can specify the option and the server multiple times to specify multiple backends. For example:

```
shell> mysql-proxy --proxy-backend-addresses 192.168.0.1:3306 --proxy-backend-addresses 192.168.0.2:3306
```

When using the option within the configuration file, you should separate multiple servers with a comma. The equivalent of the

preceding example would be:

```
...
proxy-backend-addresses = 192.168.0.1:3306, 192.168.0.2:3306
```

- `--proxy-pool-no-change-user`

Command-Line Format	<code>--proxy-pool-no-change-user</code>
Option-File Format	<code>proxy-pool-no-change-user</code>

Disable use of the MySQL protocol `CHANGE_USER` command when reusing a connection from the pool of connections specified by the `proxy-backend-addresses` list.

- `--proxy-skip-profiling`

Command-Line Format	<code>--proxy-skip-profiling</code>
Option-File Format	<code>proxy-skip-profiling</code>

Disable query profiling (statistics time tracking). The default is for tracking to be enabled.

- `--proxy-fix-bug-25371`

Version Removed	0.8.1
Command-Line Format	<code>--proxy-fix-bug-25371</code>
Option-File Format	<code>proxy-fix-bug-25371</code>

Enable a workaround for an issue when connecting to a MySQL server later than 5.1.12 when using a MySQL client library of any earlier version.

This option was removed in `mysql-proxy` 0.8.1. Now, `mysql-proxy` returns an error message at the protocol level if it sees a `COM_CHANGE_USER` being sent to a server that has a version from 5.1.14 to 5.1.17.

- `--proxy-lua-script=file_name, -s file_name`

Command-Line Format	<code>--proxy-lua-script=file_name</code>	
	<code>-s file_name</code>	
Option-File Format	<code>proxy-lua-script=file_name</code>	
	Permitted Values	
	Type	<code>file name</code>

The Lua script file to be loaded. Note that the script file is not physically loaded and parsed until a connection is made. Also note that the specified Lua script is reloaded for each connection; if the content of the Lua script changes while `mysql-proxy` is running, the updated content is automatically used when a new connection is made.

- `--pid-file=file_name`

Command-Line Format	<code>--pid-file=file_name</code>	
Option-File Format	<code>pid-file=file_name</code>	
	Permitted Values	
	Type	<code>file name</code>

The name of the file in which to store the process ID.

- `--user=user_name`

Command-Line Format	<code>--user=user_name</code>
Option-File Format	<code>user=user_name</code>

	Permitted Values	
	Type	string

Run `mysql-proxy` as the specified `user`.

- `--version, -V`

Command-Line Format	<code>--version</code>
	<code>-V</code>
Option-File Format	<code>version</code>

Show the version number.

The most common usage is as a simple proxy service (that is, without additional scripting). For basic proxy operation, you must specify at least one `proxy-backend-addresses` option to specify the MySQL server to connect to by default:

```
shell> mysql-proxy --proxy-backend-addresses=MySQL.example.com:3306
```

The default proxy port is `4040`, so you can connect to your MySQL server through the proxy by specifying the host name and port details:

```
shell> mysql --host=localhost --port=4040
```

If your server requires authentication information, this will be passed through natively without alteration by `mysql-proxy`, so you must also specify the required authentication information:

```
shell> mysql --host=localhost --port=4040 \
--user=user_name --password=password
```

You can also connect to a read-only port (which filters out `UPDATE` and `INSERT` queries) by connecting to the read-only port. By default the host name is the default, and the port is `4042`, but you can alter the host/port information by using the `-proxy-read-only-backend-addresses` command-line option.

For more detailed information on how to use these command-line options, and `mysql-proxy` in general in combination with Lua scripts, see [Section 6.5, “Using MySQL Proxy”](#).

6.4. MySQL Proxy Scripting

You can control how MySQL Proxy manipulates and works with the queries and results that are passed on to the MySQL server through the use of the embedded Lua scripting language. You can find out more about the Lua programming language from the [Lua Web site](#).

The following diagram shows an overview of the classes exposed by MySQL Proxy.

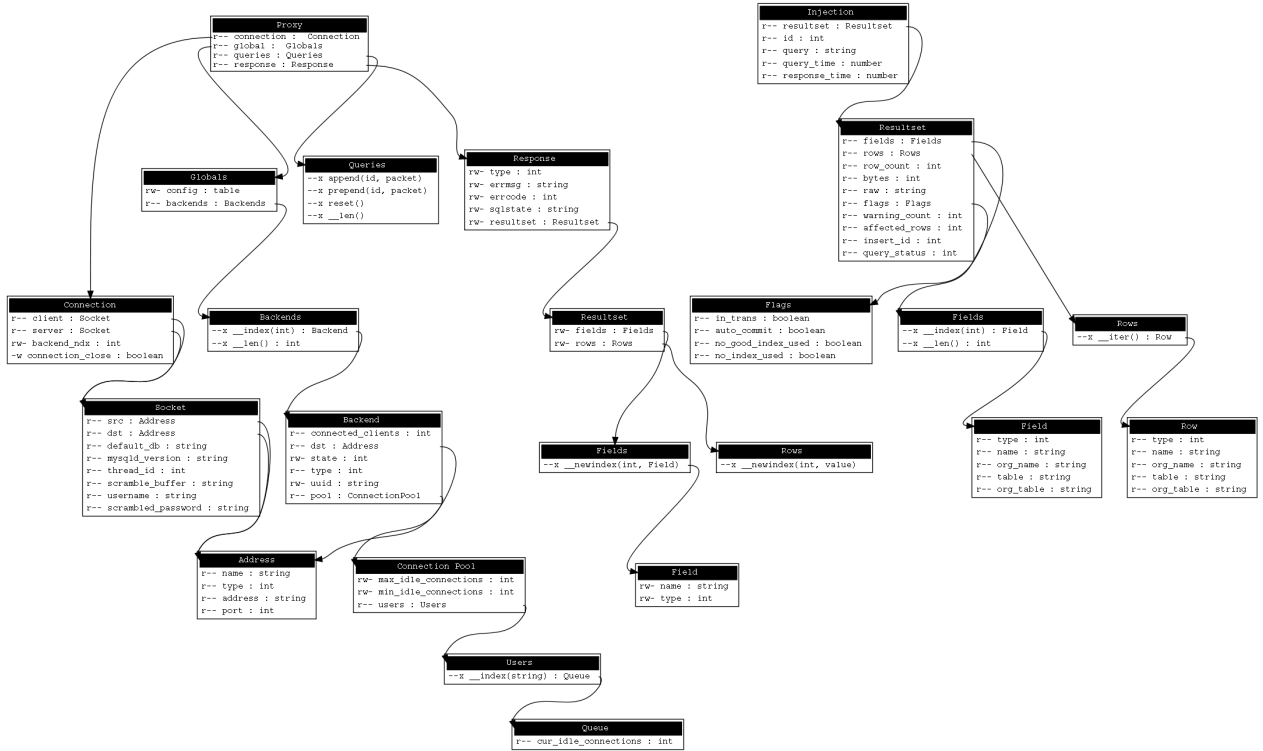

The primary interaction between MySQL Proxy and the server is provided by defining one or more functions through an Lua script. A number of functions are supported, according to different events and operations in the communication sequence between a client and one or more backend MySQL servers:

- [connect_server\(\)](#) : This function is called each time a connection is made to MySQL Proxy from a client. You can use this function during load-balancing to intercept the original connection and decide which server the client should ultimately be attached to. If you do not define a special solution, a simple round-robin style distribution is used by default.
- [read_handshake\(\)](#) : This function is called when the initial handshake information is returned by the server. You can capture the handshake information returned and provide additional checks before the authorization exchange takes place.
- [read_auth\(\)](#) : This function is called when the authorization packet (user name, password, default database) are submitted by the client to the server for authentication.
- [read_auth_result\(\)](#) : This function is called when the server returns an authorization packet to the client indicating whether the authorization succeeded.
- [read_query\(\)](#) : This function is called each time a query is sent by the client to the server. You can use this to edit and manipulate the original query, including adding new queries before and after the original statement. You can also use this function to return information directly to the client, bypassing the server, which can be useful to filter unwanted queries or queries that exceed known limits.
- [read_query_result\(\)](#) : This function is called each time a result is returned from the server, providing you have manually injected queries into the query queue. If you have not explicitly injected queries within the [read_query\(\)](#) function, this function is not triggered. You can use this to edit the result set, or to remove or filter the result sets generated from additional queries you injected into the queue when using [read_query\(\)](#).

The following table describes the direction of information flow at the point when the function is triggered.

Function	Supplied Information	Direction
connect_server()	None	Client to Server
read_handshake()	None	Server to Client
read_auth()	None	Client to Server
read_auth_result()	None	Server to Client
read_query()	Query	Client to Server
read_query_result()	Query result	Server to Client

By default, all functions return a result that indicates whether the data should be passed on to the client or server (depending on the direction of the information being transferred). This return value can be overridden by explicitly returning a constant indicating that a particular response should be sent. For example, it is possible to construct result set information by hand within `read_query()` and to return the result set directly to the client without ever sending the original query to the server.

In addition to these functions, a number of built-in structures provide control over how MySQL Proxy forwards queries and returns the results by providing a simplified interface to elements such as the list of queries and the groups of result sets that are returned.

6.4.1. Proxy Scripting Sequence During Query Injection

The following figure gives an example of how the proxy might be used when injecting queries into the query queue. Because the proxy sits between the client and MySQL server, what the proxy sends to the server, and the information that the proxy ultimately returns to the client, need not match or correlate. Once the client has connected to the proxy, the sequence shown in the following diagram occurs for each individual query sent by the client.

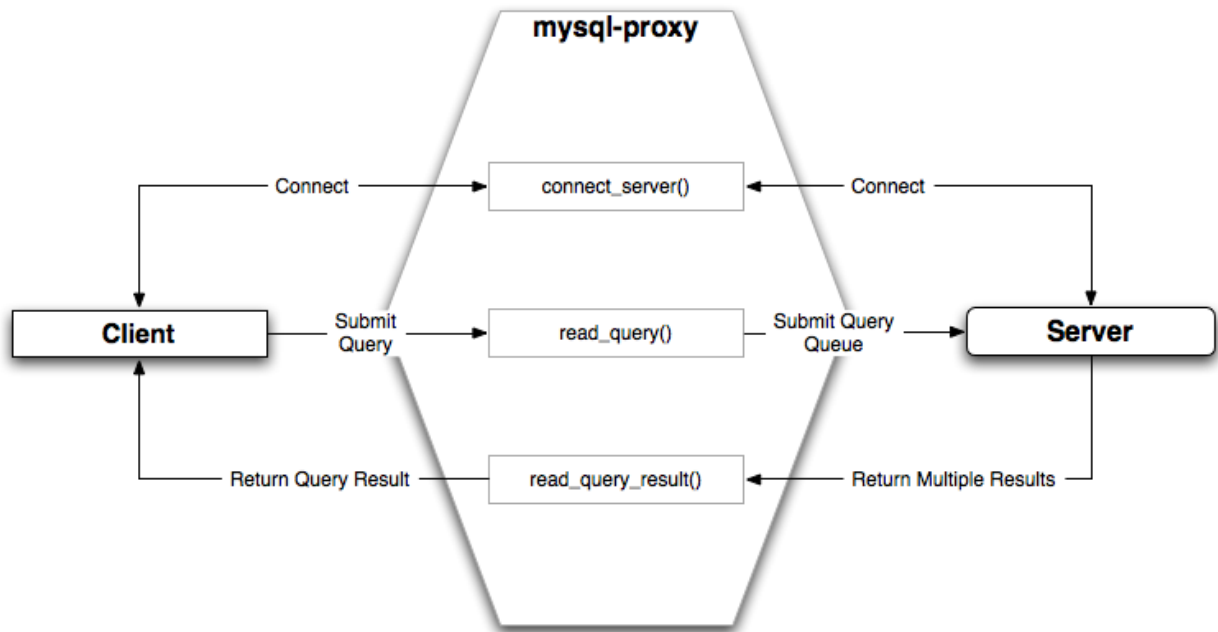

1. When the client submits one query to the proxy, the `read_query()` function within the proxy is triggered. The function adds the query to the query queue.
2. Once manipulation by `read_query()` has completed, the queries are submitted, sequentially, to the MySQL server.
3. The MySQL server returns the results from each query, one result set for each query submitted. The `read_query_result()` function is triggered for each result set, and each invocation can decide which result set to return to the client

For example, you can queue additional queries into the global query queue to be processed by the server. This can be used to add statistical information by adding queries before and after the original query, changing the original query:

```
SELECT * FROM City;
```

Into a sequence of queries:

```
SELECT NOW();
SELECT * FROM City;
SELECT NOW();
```

You can also modify the original statement; for example, to add `EXPLAIN` to each statement executed to get information on how the statement was processed, again altering our original SQL statement into a number of statements:

```
SELECT * FROM City;
EXPLAIN SELECT * FROM City;
```

In both of these examples, the client would have received more result sets than expected. Regardless of how you manipulate the incoming query and the returned result, the number of queries returned by the proxy must match the number of original queries sent by the client.

You could adjust the client to handle the multiple result sets sent by the proxy, but in most cases you will want the existence of the proxy to remain transparent. To ensure that the number of queries and result sets match, you can use the MySQL Proxy `read_query_result()` to extract the additional result set information and return only the result set the client originally requested back to the client. You can achieve this by giving each query that you add to the query queue a unique ID, then filter out queries that do not match the original query ID when processing them with `read_query_result()`.

6.4.2. Internal Structures

There are a number of internal structures within the scripting element of MySQL Proxy. The primary structure is `proxy` and this provides an interface to the many common structures used throughout the script, such as connection lists and configured backend servers. Other structures, such as the incoming packet from the client and result sets are only available within the context of one of the scriptable functions.

Attribute	Description
<code>connection</code>	A structure containing the active client connections. For a list of attributes, see <code>proxy.connection</code> .
<code>servers</code>	A structure containing the list of configured backend servers. For a list of attributes, see <code>proxy.global.backends</code> .
<code>queries</code>	A structure containing the queue of queries that will be sent to the server during a single client query. For a list of attributes, see <code>proxy.queries</code> .
<code>PROXY_VERSION</code>	The version number of MySQL Proxy, encoded in hex. You can use this to check that the version number supports a particular option from within the Lua script. Note that the value is encoded as a hex value, so to check the version is at least 0.5.1 you compare against <code>0x00501</code> .

`proxy.connection`

The `proxy.connection` object is read only, and provides information about the current connection, and is split into a `client` and `server` tables. This enables you to examine information about both the incoming client connections to the proxy (`client`), and to the backend servers (`server`).

Attribute	Description
<code>client.default_db</code>	Default database requested by the client
<code>client.username</code>	User name used to authenticate
<code>client.scrambled_password</code>	The scrambled version of the password used to authenticate
<code>client.dst.name</code>	The combined <code>address:port</code> of the Proxy port used by this client (should match the <code>--proxy-address</code> configuration parameter)
<code>client.dst.address</code>	The IP address of the of the Proxy port used by this client
<code>client.dst.port</code>	The port number of the of the Proxy port used by this client
<code>client.src.name</code>	The combined <code>address:port</code> of the client (originating) TCP/IP endpoint
<code>client.src.address</code>	The IP address of the client (originating) TCP/IP port
<code>client.src.port</code>	The port of the client (originating) TCP/IP endpoint
<code>server.scramble_buffer</code>	The scramble buffer used to scramble the password
<code>server.mysql_version</code>	The MySQL version number of the server
<code>server.thread_id</code>	The ID of the thread handling the connection to the current server
<code>server.dst.name</code>	The combined <code>address:port</code> for the backend server for the current connection (i.e. the connection to the MySQL server)
<code>server.dst.address</code>	The address for the backend server
<code>server.dst.port</code>	The port for the backend server
<code>server.src.name</code>	The combined <code>address:port</code> for the TCP/IP endpoint used by the Proxy to connect to the backend server
<code>server.src.address</code>	The address of the endpoint for the proxy-side connection to the MySQL server
<code>server.src.port</code>	The port of the endpoint for the proxy-side connection to the MySQL server

`proxy.global.backends`

The `proxy.global.backends` table is partially writable and contains an array of all the configured backend servers and the server metadata (IP address, status, etc.). You can determine the array index of the current connection using `proxy.connection["backend_ndx"]` which is the index into this table of the backend server being used by the active connection.

The attributes for each entry within the `proxy.global.backends` table are shown in this table.

Attribute	Description
<code>dst.name</code>	The combined <code>address:port</code> of the backend server.
<code>dst.address</code>	The IP address of the backend server.
<code>dst.port</code>	The port of the backend server.
<code>connected_clients</code>	The number of clients currently connected.
<code>state</code>	The status of the backend server. See Backend State/Type Constants [98]
<code>type</code>	The type of the backend server. You can use this to identify whether the backed was configured as a standard read/write backend, or a read-only backend. You can compare this value to the <code>proxy.BACKEND_TYPE_RW</code> and <code>proxy.BACKEND_TYPE_RO</code> .

`proxy.queries`

The `proxy.queries` object is a queue representing the list of queries to be sent to the server. The queue is not populated automatically, but if you do not explicitly populate the queue, queries are passed on to the backend server verbatim. Also, if you do not populate the query queue by hand, the `read_query_result()` function is not triggered.

The following methods are supported for populating the `proxy.queries` object.

Function	Description
<code>append(id,packet,[options])</code>	Appends a query to the end of the query queue. The <code>id</code> is an integer identifier that you can use to recognize the query results when they are returned by the server. The packet should be a properly formatted query packet. The optional <code>options</code> should be a table containing the options specific to this packet.
<code>prepend(id,packet)</code>	Prepends a query to the query queue. The <code>id</code> is an identifier that you can use to recognize the query results when they are returned by the server. The packet should be a properly formatted query packet.
<code>reset()</code>	Empties the query queue.
<code>len()</code>	Returns the number of query packets in the queue.

For example, you could append a query packet to the `proxy.queries` queue by using the `append()`:

```
proxy.queries:append(1,packet)
```

The optional third argument to `append()` should contain the options for the packet. If you want to have access to the result set through the `read_query_result()` function, you must set the `resultset_is_needed` flag to `true`:

```
proxy.queries:append( 1, packet, { resultset_is_needed = true } )
```

If that flag is `false` (the default), proxy will:

- Send the result set to the client as soon as it is received
- Reduce memory usage (because the result set is not stored internally for processing)
- Reduce latency of returning results to the client
- Pass data from server to client unaltered

The default mode is therefore quicker and useful if you only want to monitor the queries sent, and the basic statistics.

If, however, you want to perform any kind of manipulation on the returned data, you must set the flag to `true`, which will:

- Store the result set so that it can be processed
- Enable modification of the result set before it is returned to the client
- Enable you to discard the result set instead of returning it to the client

proxy.response

The `proxy.response` structure is used when you want to return your own MySQL response, instead of forwarding a packet that you have received a backend server. The structure holds the response type information, an optional error message, and the result set (rows/columns) that you want to return.

Attribute	Description
<code>type</code>	The type of the response. The type must be either <code>MYSQLD_PACKET_OK</code> or <code>MYSQLD_PACKET_ERR</code> . If the <code>MYSQLD_PACKET_ERR</code> , you should set the value of the <code>mysql.response.errmsg</code> with a suitable error message.
<code>errmsg</code>	A string containing the error message that will be returned to the client.
<code>resultset</code>	A structure containing the result set information (columns and rows), identical to what would be returned when returning a results from a <code>SELECT</code> query.

When using `proxy.response` you either set `proxy.response.type` to `proxy.MYSQLD_PACKET_OK` and then build `resultset` to contain the results that you want to return, or set `proxy.response.type` to `proxy.MYSQLD_PACKET_ERR` and set the `proxy.response.errmsg` to a string with the error message. To send the completed result set or error message, you should return the `proxy.PROXY_SEND_RESULT` to trigger the return of the packet information.

An example of this can be seen in the `tutorial-resultset.lua` script within the MySQL Proxy package:

```
if string.lower(command) == "show" and string.lower(option) == "querycounter" then
    ---
    --- proxy.PROXY_SEND_RESULT requires
    ---
    --- proxy.response.type to be either
    --- * proxy.MYSQLD_PACKET_OK or
    --- * proxy.MYSQLD_PACKET_ERR
    ---
    --- for proxy.MYSQLD_PACKET_OK you need a resultset
    --- * fields
    --- * rows
    ---
    --- for proxy.MYSQLD_PACKET_ERR
    --- * errmsg
    proxy.response.type = proxy.MYSQLD_PACKET_OK
    proxy.response.resultset = {
        fields = {
            { type = proxy.MYSQL_TYPE_LONG, name = "global_query_counter", },
            { type = proxy.MYSQL_TYPE_LONG, name = "query_counter", },
        },
        rows = {
            { proxy.global.query_counter, query_counter }
        }
    }
    --- we have our result, send it back
    return proxy.PROXY_SEND_RESULT
elseif string.lower(command) == "show" and string.lower(option) == "myerror" then
    proxy.response.type = proxy.MYSQLD_PACKET_ERR
    proxy.response.errmsg = "my first error"
    return proxy.PROXY_SEND_RESULT
end
```

proxy.response.resultset

The `proxy.response.resultset` structure should be populated with the rows and columns of data that you want to return. The structure contains the information about the entire result set, with the individual elements of the data shown in the following table.

Attribute	Description
<code>fields</code>	The definition of the columns being returned. This should be a dictionary structure with the <code>type</code> specifying the MySQL data type, and the <code>name</code> specifying the column name. Columns should be listed in the order of the column data that will be returned.
<code>flags</code>	A number of flags related to the result set. Valid flags include <code>auto_commit</code> (whether an automatic commit was triggered), <code>no_good_index_used</code> (the query executed without using an appropriate index), and <code>no_index_used</code> (the query executed without using any index).
<code>rows</code>	The actual row data. The information should be returned as an array of arrays. Each inner

Attribute	Description
	array should contain the column data, with the outer array making up the entire result set.
<code>warning_count</code>	The number of warnings for this result set.
<code>affected_rows</code>	The number of rows affected by the original statement.
<code>insert_id</code>	The last insert ID for an auto-incremented column in a table.
<code>query_status</code>	The status of the query operation. You can use the <code>MYSQLD_PACKET_OK</code> or <code>MYSQLD_PACKET_ERR</code> constants to populate this parameter.

For an example showing how to use this structure, see `proxy.response`.

Proxy Return State Constants

The following constants are used internally by the proxy to specify the response to send to the client or server. All constants are exposed as values within the main `proxy` table.

Constant	Description
<code>PROXY_SEND_QUERY</code>	Causes the proxy to send the current contents of the queries queue to the server.
<code>PROXY_SEND_RESULT</code>	Causes the proxy to send a result set back to the client.
<code>PROXY_IGNORE_RESULT</code>	Causes the proxy to drop the result set (nothing is returned to the client).

As constants, these entities are available without qualification in the Lua scripts. For example, at the end of the `read_query_result()` you might return `PROXY_IGNORE_RESULT`:

```
return proxy.PROXY_IGNORE_RESULT
```

Packet State Constants

The following states describe the status of a network packet. These items are entries within the main `proxy` table.

Constant	Description
<code>MYSQLD_PACKET_OK</code>	The packet is OK
<code>MYSQLD_PACKET_ERR</code>	The packet contains error information
<code>MYSQLD_PACKET_RAW</code>	The packet contains raw data

Backend State/Type Constants

The following constants are used either to define the status or type of the backend MySQL server to which the proxy is connected. These items are entries within the main `proxy` table.

Constant	Description
<code>BACKEND_STATE_UNKNOWN</code>	The current status is unknown
<code>BACKEND_STATE_UP</code>	The backend is known to be up (available)
<code>BACKEND_STATE_DOWN</code>	The backend is known to be down (unavailable)
<code>BACKEND_TYPE_UNKNOWN</code>	Backend type is unknown
<code>BACKEND_TYPE_RW</code>	Backend is available for read/write
<code>BACKEND_TYPE_RO</code>	Backend is available only for read-only use

Server Command Constants

The following values are used in the packets exchanged between the client and server to identify the information in the rest of the packet. These items are entries within the main `proxy` table. The packet type is defined as the first character in the sent packet. For example, when intercepting packets from the client to edit or monitor a query, you would check that the first byte of the packet was of type `proxy.COM_QUERY`.

Constant	Description
<code>COM_SLEEP</code>	Sleep

Constant	Description
COM_QUIT	Quit
COM_INIT_DB	Initialize database
COM_QUERY	Query
COM_FIELD_LIST	Field List
COM_CREATE_DB	Create database
COM_DROP_DB	Drop database
COM_REFRESH	Refresh
COM_SHUTDOWN	Shutdown
COM_STATISTICS	Statistics
COM_PROCESS_INFO	Process List
COM_CONNECT	Connect
COM_PROCESS_KILL	Kill
COM_DEBUG	Debug
COM_PING	Ping
COM_TIME	Time
COM_DELAYED_INSERT	Delayed insert
COM_CHANGE_USER	Change user
COM_BINLOG_DUMP	Binlog dump
COM_TABLE_DUMP	Table dump
COM_CONNECT_OUT	Connect out
COM_REGISTER_SLAVE	Register slave
COM_STMT_PREPARE	Prepare server-side statement
COM_STMT_EXECUTE	Execute server-side statement
COM_STMT_SEND_LONG_DATA	Long data
COM_STMT_CLOSE	Close server-side statement
COM_STMT_RESET	Reset statement
COM_SET_OPTION	Set option
COM_STMT_FETCH	Fetch statement
COM_DAEMON	Daemon (MySQL 5.1 only)
COM_ERROR	Error

MySQL Type Constants

These constants are used to identify the field types in the query result data returned to clients from the result of a query. These items are entries within the main `proxy` table.

Constant	Field Type
MYSQL_TYPE_DECIMAL	Decimal
MYSQL_TYPE_NEWDECIMAL	Decimal (MySQL 5.0 or later)
MYSQL_TYPE_TINY	Tiny
MYSQL_TYPE_SHORT	Short
MYSQL_TYPE_LONG	Long
MYSQL_TYPE_FLOAT	Float
MYSQL_TYPE_DOUBLE	Double
MYSQL_TYPE_NULL	Null
MYSQL_TYPE_TIMESTAMP	Timestamp
MYSQL_TYPE_LONGLONG	Long long
MYSQL_TYPE_INT24	Integer
MYSQL_TYPE_DATE	Date

Constant	Field Type
<code>MYSQL_TYPE_TIME</code>	Time
<code>MYSQL_TYPE_DATETIME</code>	Datetime
<code>MYSQL_TYPE_YEAR</code>	Year
<code>MYSQL_TYPE_NEWDATE</code>	Date (MySQL 5.0 or later)
<code>MYSQL_TYPE_ENUM</code>	Enumeration
<code>MYSQL_TYPE_SET</code>	Set
<code>MYSQL_TYPE_TINY_BLOB</code>	Tiny Blob
<code>MYSQL_TYPE_MEDIUM_BLOB</code>	Medium Blob
<code>MYSQL_TYPE_LONG_BLOB</code>	Long Blob
<code>MYSQL_TYPE_BLOB</code>	Blob
<code>MYSQL_TYPE_VAR_STRING</code>	Varstring
<code>MYSQL_TYPE_STRING</code>	String
<code>MYSQL_TYPE_TINY</code>	Tiny (compatible with <code>MYSQL_TYPE_CHAR</code>)
<code>MYSQL_TYPE_ENUM</code>	Enumeration (compatible with <code>MYSQL_TYPE_INTERVAL</code>)
<code>MYSQL_TYPE_GEOMETRY</code>	Geometry
<code>MYSQL_TYPE_BIT</code>	Bit

6.4.3. Capturing a Connection with `connect_server()`

When the proxy accepts a connection from a MySQL client, the `connect_server()` function is called.

There are no arguments to the function, but you can use and if necessary manipulate the information in the `proxy.connection` table, which is unique to each client session.

For example, if you have multiple backend servers, you can specify which server that connection should use by setting the value of `proxy.connection.backend_ndx` to a valid server number. The following code chooses between two servers based on whether the current time in minutes is odd or even:

```
function connect_server()
  print("--> a client really wants to talk to a server")
  if (tonumber(os.date("%M")) % 2 == 0) then
    proxy.connection.backend_ndx = 2
    print("Choosing backend 2")
  else
    proxy.connection.backend_ndx = 1
    print("Choosing backend 1")
  end
  print("Using " .. proxy.global.backends[proxy.connection.backend_ndx].dst.name)
end
```

This example also displays the IP address/port combination by accessing the information from the internal `proxy.global.backends` table.

6.4.4. Examining the Handshake with `read_handshake()`

Handshake information is sent by the server to the client after the initial connection (through `connect_server()`) has been made. The handshake information contains details about the MySQL version, the ID of the thread that will handle the connection information, and the IP address of the client and server. This information is exposed through the `proxy.connection` structure.

- `proxy.connection.server.mysql_version`: The version of the MySQL server.
- `proxy.connection.server.thread_id`: The thread ID.
- `proxy.connection.server.scramble_buffer`: The password scramble buffer.
- `proxy.connection.server.dst.name`: The IP address of the server.
- `proxy.connection.client.src.name`: The IP address of the client.

For example, you can print out the handshake data and refuse clients by IP address with the following function:

```
function read_handshake()
  print("<-- let's send him some information about us")
  print("  mysql-version: " .. proxy.connection.server.mysql_version)
  print("  thread-id      : " .. proxy.connection.server.thread_id)
  print("  scramble-buf   : " .. string.format("%q", proxy.connection.server.scramble_buffer))
  print("  server-addr    : " .. proxy.connection.server.dst.name)
  print("  client-addr    : " .. proxy.connection.client.dst.name)
  if not proxy.connection.client.src.name:match("^127.0.0.1:") then
    proxy.response.type = proxy.MYSQLD_PACKET_ERR
    proxy.response.errmsg = "only local connects are allowed"
    print("we don't like this client");
    return proxy.PROXY_SEND_RESULT
  end
end
end
```

Note that you must return an error packet to the client by using `proxy.PROXY_SEND_RESULT`.

6.4.5. Examining the Authentication Credentials with `read_auth()`

The `read_auth()` function is triggered when an authentication handshake is initiated by the client. In the execution sequence, `read_auth()` occurs immediately after `read_handshake()`, so the server selection has already been made, but the connection and authorization information has not yet been provided to the backend server.

You can obtain the authentication information by examining the `proxy.connection.client` structure. For more information, see `proxy.connection`.

For example, you can print the user name and password supplied during authorization using:

```
function read_auth()
  print("  username      : " .. proxy.connection.client.username)
  print("  password     : " .. string.format("%q", proxy.connection.client.scrambled_password))
end
```

You can interrupt the authentication process within this function and return an error packet back to the client by constructing a new packet and returning `proxy.PROXY_SEND_RESULT`:

```
proxy.response.type = proxy.MYSQLD_PACKET_ERR
proxy.response.errmsg = "Logins are not allowed"
return proxy.PROXY_SEND_RESULT
```

6.4.6. Accessing Authentication Information with `read_auth_result()`

The return packet from the server during authentication is captured by `read_auth_result()`. The only argument to this function is the authentication packet returned by the server. As the packet is a raw MySQL network protocol packet, you must access the first byte to identify the packet type and contents. The `MYSQLD_PACKET_ERR` and `MYSQLD_PACKET_OK` constants can be used to identify whether the authentication was successful:

```
function read_auth_result(auth)
  local state = auth.packet:byte()
  if state == proxy.MYSQLD_PACKET_OK then
    print("<-- auth ok");
  elseif state == proxy.MYSQLD_PACKET_ERR then
    print("<-- auth failed");
  else
    print("<-- auth ... don't know: " .. string.format("%q", auth.packet));
  end
end
```

If a long-password capable client tries to authenticate to a server that supports long passwords, but the user password provided is actually short, `read_auth_result()` will be called twice. The first time, `auth.packet:byte()` will equal 254, indicating that the client should try again using the old password protocol. The second time time `read_auth_result()` is called, `auth.packet:byte()` will indicate whether the authentication actually succeeded.

6.4.7. Manipulating Queries with `read_query()`

The `read_query()` function is called once for each query submitted by the client and accepts a single argument, the query packet that was provided. To access the content of the packet, you must parse the packet contents manually.

For example, you can intercept a query packet and print out the contents using the following function definition:

```
function read_query( packet )
  if packet:byte() == proxy.COM_QUERY then
    print("we got a normal query: " .. packet:sub(2))
  end
end
```

This example checks the first byte of the packet to determine the type. If the type is `COM_QUERY` (see [Server Command Constants \[98\]](#)), we extract the query from the packet and print it. The structure of the packet type supplied is important. In the case of a `COM_QUERY` packet, the remaining contents of the packet are the text of the query string. In this example, no changes have been made to the query or the list of queries that will ultimately be sent to the MySQL server.

To modify a query, or add new queries, you must populate the query queue (`proxy.queries`), then execute the queries that you have placed into the queue. If you do not modify the original query or the queue, the query received from the client is sent to the MySQL server verbatim.

When adding queries to the queue, you should follow these guidelines:

- The packets inserted into the queue must be valid query packets. For each packet, you must set the initial byte to the packet type. If you are appending a query, you can append the query statement to the rest of the packet.
- Once you add a query to the queue, the queue is used as the source for queries sent to the server. If you add a query to the queue to add more information, you must also add the original query to the queue or it will not be executed.
- Once the queue has been populated, you must set the return value from `read_query()` to indicate whether the query queue should be sent to the server.
- When you add queries to the queue, you should add an ID. The ID you specify is returned with the result set so that you identify each query and corresponding result set. The ID has no other purpose than as an identifier for correlating the query and result set. When operating in a passive mode, during profiling for example, you want to identify the original query and the corresponding result set so that the results expect by the client can be returned correctly.
- Unless your client is designed to cope with more result sets than queries, you should ensure that the number of queries from the client match the number of results returned to the client. Using the unique ID and removing result sets you inserted will help.

Normally, the `read_query()` and `read_query_result()` function are used in conjunction with each other to inject additional queries and remove the additional result sets. However, `read_query_result()` is only called if you populate the query queue within `read_query()`.

6.4.8. Manipulating Results with `read_query_result()`

The `read_query_result()` is called for each result set returned by the server only if you have manually injected queries into the query queue. If you have not manipulated the query queue, this function is not called. The function supports a single argument, the result packet, which provides a number of properties:

- `id`: The ID of the result set, which corresponds to the ID that was set when the query packet was submitted to the server when using `append(id)` on the query queue. You must have set the `resultset_is_needed` flag to `append` to intercept the result set before it is returned to the client. See [proxy.queries \[96\]](#).
- `query`: The text of the original query.
- `query_time`: The number of microseconds required to receive the first row of a result set since the query was sent to the server.
- `response_time`: The number of microseconds required to receive the last row of the result set since the query was sent to the server.
- `resultset`: The content of the result set data.

By accessing the result information from the MySQL server, you can extract the results that match the queries that you injected, return different result sets (for example, from a modified query), and even create your own result sets.

The following Lua script, for example, will output the query, followed by the query time and response time (that is, the time to execute the query and the time to return the data for the query) for each query sent to the server:

```
function read_query( packet )
    if packet:byte() == proxy.COM_QUERY then
        print("we got a normal query: " .. packet:sub(2))
        proxy.queries:append(1, packet )
        return proxy.PROXY_SEND_QUERY
    end
end
function read_query_result(inj)
    print("query-time: " .. (inj.query_time / 1000) .. "ms")
    print("response-time: " .. (inj.response_time / 1000) .. "ms")
end
```

You can access the rows of returned results from the result set by accessing the `rows` property of the `resultset` property of the result that is exposed through `read_query_result()`. For example, you can iterate over the results showing the first column from each row using this Lua fragment:

```
for row in inj.resultset.rows do
    print("injected query returned: " .. row[1])
end
```

Just like `read_query()`, `read_query_result()` can return different values for each result according to the result returned. If you have injected additional queries into the query queue, for example, you will want to remove the results returned from those additional queries and return only the results from the query originally submitted by the client.

The following example injects additional `SELECT NOW()` statements into the query queue, giving them a different ID to the ID of the original query. Within `read_query_result()`, if the ID for the injected queries is identified, we display the result row, and return the `proxy.PROXY_IGNORE_RESULT` from the function so that the result is not returned to the client. If the result is from any other query, we print out the query time information for the query and return the default, which passes on the result set unchanged. We could also have explicitly returned `proxy.PROXY_IGNORE_RESULT` to the MySQL client.

```
function read_query( packet )
    if packet:byte() == proxy.COM_QUERY then
        proxy.queries:append(2, string.char(proxy.COM_QUERY) .. "SELECT NOW()", {resultset_is_needed = true} )
        proxy.queries:append(1, packet, {resultset_is_needed = true})
        proxy.queries:append(2, string.char(proxy.COM_QUERY) .. "SELECT NOW()", {resultset_is_needed = true} )
    end
end
function read_query_result(inj)
    if inj.id == 2 then
        for row in inj.resultset.rows do
            print("injected query returned: " .. row[1])
        end
        return proxy.PROXY_IGNORE_RESULT
    else
        print("query-time: " .. (inj.query_time / 1000) .. "ms")
        print("response-time: " .. (inj.response_time / 1000) .. "ms")
    end
end
```

For further examples, see [Section 6.5, “Using MySQL Proxy”](#).

6.5. Using MySQL Proxy

There are a number of different ways to use MySQL Proxy. At the most basic level, you can allow MySQL Proxy to pass queries from clients to a single server. To use MySQL Proxy in this mode, you just have to specify on the command line the backend server to which the proxy should connect:

```
shell> mysql-proxy --proxy-backend-addresses=sakila:3306
```

If you specify multiple backend MySQL servers, the proxy connects each client to each server in a round-robin fashion. Suppose that you have two MySQL servers, A and B. The first client to connect is connected to server A, the second to server B, the third to server A. For example:

```
shell> mysql-proxy \
--proxy-backend-addresses=narcissus:3306 \
--proxy-backend-addresses=nostromo:3306
```

When you specify multiple servers in this way, the proxy automatically identifies when a MySQL server has become unavailable and marks it accordingly. New connections are automatically attached to a server that is available, and a warning is reported to the standard output from `mysql-proxy`:

```
network-mysqld.c.367: connect(nostromo:3306) failed: Connection refused
network-mysqld-proxy.c.2405: connecting to backend (nostromo:3306) failed, marking it as down for ...
```

Lua scripts enable a finer level of control, both over the connections and their distribution and how queries and result sets are processed. When using an Lua script, you must specify the name of the script on the command line using the `-proxy-lua-script` option:

```
shell> mysql-proxy --proxy-lua-script=mc.lua --proxy-backend-addresses=sakila:3306
```

When you specify a script, the script is not executed until a connection is made. This means that faults with the script are not raised until the script is executed. Script faults will not affect the distribution of queries to backend MySQL servers.

Note

Because a script is not read until the connection is made, you can modify the contents of the Lua script file while the proxy is still running and the modified script is automatically used for the next connection. This ensures that MySQL Proxy remains available because it need not be restarted for the changes to take effect.

6.5.1. Using the Administration Interface

The `mysql-proxy` administration interface can be accessed using any MySQL client using the standard protocols. You can use the administration interface to gain information about the proxy server as a whole - standard connections to the proxy are isolated to operate as if you were connected directly to the backend MySQL server.

In `mysql-proxy` 0.8.0 and earlier, a rudimentary interface was built into the proxy. In later versions this was replaced so that you must specify an administration script to be used when users connect to the administration interface.

To use the administration interface, you should specify the user name and password required to connect to the admin service (using the `--admin-username` and `--admin-password` options). You must also specify the Lua script to be used as the interface to the administration service by using the `admin-lua-script` script option to point to a Lua script.

For example, you can create a basic interface to the internal components of the `mysql-proxy` system using the following script, written by Diego Medina:

```
--[[
Copyright 2008, 2010, Oracle and/or its affiliates. All rights reserved.

This program is free software; you can redistribute it and/or modify
it under the terms of the GNU General Public License as published by
the Free Software Foundation; version 2 of the License.
This program is distributed in the hope that it will be useful,
but WITHOUT ANY WARRANTY; without even the implied warranty of
MERCHANTABILITY or FITNESS FOR A PARTICULAR PURPOSE. See the
GNU General Public License for more details.
You should have received a copy of the GNU General Public License
along with this program; if not, write to the Free Software
Foundation, Inc., 51 Franklin Street, Fifth Floor, Boston, MA 02110-1301 USA
--]]
-- admin.lua
--[[
See http://forge.mysql.com/tools/tool.php?id=78
(Thanks to Jan Kneschke)
See http://www.chriscalender.com/?p=41
(Thanks to Chris Calender)
See http://datacharmer.blogspot.com/2009/01/mysql-proxy-is-back.html
(Thanks Giuseppe Maxia)
--]]
function set_error(errmsg)
    proxy.response = {
        type = proxy.MYSQLD_PACKET_ERR,
        errmsg = errmsg or "error"
    }
end
function read_query(packet)
    if packet:byte() ~= proxy.COM_QUERY then
        set_error("[admin] we only handle text-based queries (COM_QUERY)")
        return proxy.PROXY_SEND_RESULT
    end
    local query = packet:sub(2)
    local rows = { }
    local fields = { }
    -- try to match the string up to the first non-alphanum
    local f_s, f_e, command = string.find(packet, "^%s*(%w+)", 2)
    local option
    if f_e then
        -- if that match, take the next sub-string as option
        f_s, f_e, option = string.find(packet, "^%s+(%w+)", f_e + 1)
    end
    -- we got our commands, execute it
    if command == "show" and option == "querycounter" then
        ---
        --- proxy.PROXY_SEND_RESULT requires
        ---
        --- proxy.response.type to be either
        --- * proxy.MYSQLD_PACKET_OK or
        --- * proxy.MYSQLD_PACKET_ERR
        ---
        --- for proxy.MYSQLD_PACKET_OK you need a resultset
        --- * fields
        --- * rows
        ---
        --- for proxy.MYSQLD_PACKET_ERR
        --- * errmsg
        proxy.response.type = proxy.MYSQLD_PACKET_OK
        proxy.response.resultset = {
            fields = {
                { type = proxy.MYSQL_TYPE_LONG, name = "query_counter", },
            },
            rows = {
                { proxy.global.query_counter }
            }
        }
    end
end
```

```

    }
    }
    -- we have our result, send it back
    return proxy.PROXY_SEND_RESULT
elseif command == "show" and option == "myerror" then
    proxy.response.type = proxy.MYSQLD_PACKET_ERR
    proxy.response.errmsg = "my first error"
    return proxy.PROXY_SEND_RESULT

elseif string.sub(packet, 2):lower() == 'select help' then
    return show_process_help()

elseif string.sub(packet, 2):lower() == 'show proxy processlist' then
    return show_process_table()
elseif query == "SELECT * FROM backends" then
    fields = {
        { name = "backend_ndx",
          type = proxy.MYSQL_TYPE_LONG },
        { name = "address",
          type = proxy.MYSQL_TYPE_STRING },
        { name = "state",
          type = proxy.MYSQL_TYPE_STRING },
        { name = "type",
          type = proxy.MYSQL_TYPE_STRING },
    }
    for i = 1, #proxy.global.backends do
        local b = proxy.global.backends[i]
        rows[#rows + 1] = {
            i, b.dst.name, b.state, b.type
        }
    end
else
    set_error()
    return proxy.PROXY_SEND_RESULT
end
proxy.response = {
    type = proxy.MYSQLD_PACKET_OK,
    resultset = {
        fields = fields,
        rows = rows
    }
}
return proxy.PROXY_SEND_RESULT
end
function make_dataset (header, dataset)
    proxy.response.type = proxy.MYSQLD_PACKET_OK
    proxy.response.resultset = {
        fields = {},
        rows = {}
    }
    for i,v in pairs (header) do
        table.insert(proxy.response.resultset.fields, {type = proxy.MYSQL_TYPE_STRING, name = v})
    end
    for i,v in pairs (dataset) do
        table.insert(proxy.response.resultset.rows, v )
    end
    return proxy.PROXY_SEND_RESULT
end
function show_process_table()
    local dataset = {}
    local header = { 'Id', 'IP Address', 'Time' }
    local rows = {}
    for t_i, t_v in pairs (proxy.global.process) do
        for s_i, s_v in pairs ( t_v ) do
            table.insert(rows, { t_i, s_v.ip, os.date('%c',s_v.ts) })
        end
    end
    return make_dataset(header,rows)
end
function show_process_help()
    local dataset = {}
    local header = { 'command', 'description' }
    local rows = {
        { 'SELECT HELP', 'This command.' },
        { 'SHOW PROXY PROCESSLIST', 'Show all connections and their true IP Address.' },
    }
    return make_dataset(header,rows)
end
function dump_process_table()
    proxy.global.initialize_process_table()
    print('current contents of process table')
    for t_i, t_v in pairs (proxy.global.process) do
        print ('session id: ', t_i)
        for s_i, s_v in pairs ( t_v ) do
            print ( '\t', s_i, s_v.ip, s_v.ts )
        end
    end
    print ('---END PROCESS TABLE---')
end
--[[ Help
we use a simple string-match to split commands are word-boundaries
mysql> show querycounter
is split into
command = "show"
option = "querycounter"
spaces are ignored, the case has to be as is.
mysql> show myerror
]]

```

```
returns a error-packet
--]]
```

The script works in combination with a main proxy script, `reporter.lua`:

```
--[[
Copyright 2008, 2010, Oracle and/or its affiliates. All rights reserved.

This program is free software; you can redistribute it and/or modify
it under the terms of the GNU General Public License as published by
the Free Software Foundation; version 2 of the License.
This program is distributed in the hope that it will be useful,
but WITHOUT ANY WARRANTY; without even the implied warranty of
MERCHANTABILITY or FITNESS FOR A PARTICULAR PURPOSE. See the
GNU General Public License for more details.
You should have received a copy of the GNU General Public License
along with this program; if not, write to the Free Software
Foundation, Inc., 51 Franklin Street, Fifth Floor, Boston, MA 02110-1301 USA
--]]
-- reporter.lua
--[[
See http://forge.mysql.com/tools/tool.php?id=78
(Thanks to Jan Kneschke)
See http://www.chriscaender.com/?p=41
(Thanks to Chris Caender)
See http://datacharmer.blogspot.com/2009/01/mysql-proxy-is-back.html
(Thanks Giuseppe Maxia)
--]]
proxy.global.query_counter = proxy.global.query_counter or 0
function proxy.global.initialize_process_table()
    if proxy.global.process == nil then
        proxy.global.process = {}
    end
    if proxy.global.process[proxy.connection.server.thread_id] == nil then
        proxy.global.process[proxy.connection.server.thread_id] = {}
    end
end
function read_auth_result( auth )
    local state = auth.packet:byte()
    if state == proxy.MYSQLD_PACKET_OK then
        proxy.global.initialize_process_table()
        table.insert( proxy.global.process[proxy.connection.server.thread_id],
            { ip = proxy.connection.client.src.name, ts = os.time() } )
    end
end
function disconnect_client()
    local connection_id = proxy.connection.server.thread_id
    if connection_id then
        -- client has disconnected, set this to nil
        proxy.global.process[connection_id] = nil
    end
end
end
---
-- read_query() can return a resultset
--
-- You can use read_query() to return a result-set.
--
-- @param packet the mysql-packet sent by the client
--
-- @return
-- * nothing to pass on the packet as is,
-- * proxy.PROXY_SEND_QUERY to send the queries from the proxy.queries queue
-- * proxy.PROXY_SEND_RESULT to send your own result-set
--
function read_query( packet )
    -- a new query came in in this connection
    -- using proxy.global.* to make it available to the admin plugin
    proxy.global.query_counter = proxy.global.query_counter + 1
end
```

To use the script, save the first script to a file (`admin.lua` in the following example) and the other to `reporter.lua`, then run `mysql-proxy` specifying the admin script and a backend MySQL server:

```
shell> mysql-proxy --admin-lua-script=admin.lua --admin-password=password \ »
--admin-username=root --proxy-backend-addresses=127.0.0.1:3306 -proxy-lua-script=reporter.lua
```

In a different window, connect to the MySQL server through the proxy:

```
shell> mysql --user=root --password=password --port=4040
Welcome to the MySQL monitor. Commands end with ; or \g.
Your MySQL connection id is 1798669
Server version: 5.0.70-log Gentoo Linux mysql-5.0.70-r1
Type 'help;' or '\h' for help. Type '\c' to clear the buffer.
mysql>
```

In another different window, connect to the `mysql-proxy` admin service using the specified user name and password:

```
shell> mysql --user=root --password=password --port=4041 --host=localhost
```

```
Welcome to the MySQL monitor.  Commands end with ; or \g.
Your MySQL connection id is 1
Server version: 5.0.99-agent-admin
Type 'help;' or '\h' for help. Type '\c' to clear the buffer.
mysql>
```

To monitor the status of the proxy, ask for a list of the current active processes:

```
mysql> show proxy processlist;
+-----+-----+-----+
| Id      | IP Address          | Time                |
+-----+-----+-----+
| 1798669 | 192.168.0.112:52592 | Wed Jan 20 16:58:00 2010 |
+-----+-----+-----+
1 row in set (0.00 sec)
mysql>
```

For more information on the example, see [MySQL Proxy Admin Example](#).

6.6. MySQL Proxy FAQ

Questions

- [6.6.1](#): In load balancing, how can I separate reads from writes?
- [6.6.2](#): How do I use a socket with MySQL Proxy? Proxy change logs mention that support for UNIX sockets has been added.
- [6.6.3](#): Can I use MySQL Proxy with all versions of MySQL?
- [6.6.4](#): Can I run MySQL Proxy as a daemon?
- [6.6.5](#): Will the proxy road map involve moving popular features from Lua to C? (For example, Read/Write splitting.)
- [6.6.6](#): Do proxy applications run on a separate server? If not, what is the overhead incurred by Proxy on the DB server side?
- [6.6.7](#): With load balancing, what happens to transactions? Are all queries sent to the same server?
- [6.6.8](#): We have looked at using MySQL Proxy but we are concerned about the alpha status. When do you think the proxy will be considered production ready?
- [6.6.9](#): Is it possible to use MySQL Proxy with updating a Lucene index (or Solr) by making TCP calls to that server to update?
- [6.6.10](#): Is the system context switch expensive, how much overhead does the Lua script add?
- [6.6.11](#): How much latency does a proxy add to a connection?
- [6.6.12](#): Do you have to make one large script and call it at proxy startup, can I change scripts without stopping and restarting (interrupting) the proxy?
- [6.6.13](#): If MySQL Proxy has to live on same machine as MySQL, are there any tuning considerations to ensure both perform optimally?
- [6.6.14](#): Can MySQL Proxy be used on slaves and intercept binary log messages?
- [6.6.15](#): I currently use SQL Relay for efficient connection pooling with a number of Apache processes connecting to a MySQL server. Can MySQL Proxy currently accomplish this? My goal is to minimize connection latency while keeping temporary tables available.
- [6.6.16](#): Are these reserved function names (for example, `error_result()`) that get automatically called?
- [6.6.17](#): As the script is re-read by MySQL Proxy, does it cache this or is it looking at the file system with each request?
- [6.6.18](#): Given that there is a `connect_server()` function, can a Lua script link up with multiple servers?
- [6.6.19](#): Is the MySQL Proxy an API?
- [6.6.20](#): The global namespace variable example with quotas does not persist after a reboot, is that correct?
- [6.6.21](#): Can MySQL Proxy handle SSL connections?
- [6.6.22](#): Could MySQL Proxy be used to capture passwords?
- [6.6.23](#): Are there tools for isolating problems? How can someone figure out whether a problem is in the client, the database, or

the proxy?

- [6.6.24](#): Can you explain the status of your work with [memcached](#) and MySQL Proxy?
- [6.6.25](#): Is MySQL Proxy similar to what is provided by Java connection pools?
- [6.6.26](#): So authentication with connection pooling has to be done at every connection? What is the authentication latency?
- [6.6.27](#): If you have multiple databases on the same box, can you use proxy to connect to databases on default port 3306?
- [6.6.28](#): What about caching the authorization information so clients connecting are given back-end connections that were established with identical authorization information, thus saving a few more round trips?
- [6.6.29](#): Is there any big web site using MySQL Proxy? For what purpose and what transaction rate have they achieved?
- [6.6.30](#): How does MySQL Proxy compare to DBSLayer?
- [6.6.31](#): I tried using MySQL Proxy without any Lua script to try a round-robin type load balancing. In this case, if the first database in the list is down, MySQL Proxy would not connect the client to the second database in the list.
- [6.6.32](#): Is it “safe” to use [LuaSocket](#) with proxy scripts?
- [6.6.33](#): How different is MySQL Proxy from DBCP (Database connection pooling) for Apache in terms of connection pooling?
- [6.6.34](#): MySQL Proxy can handle about 5000 connections, what is the limit on a MySQL server?
- [6.6.35](#): Would the Java-only connection pooling solution work for multiple web servers? With this, I would assume that you can pool across many web servers at once?
- [6.6.36](#): Can you dynamically reconfigure the pool of MySQL servers that MySQL Proxy will use for load balancing?
- [6.6.37](#): In the quick poll, I see "Load Balancer: read-write splitting" as an option, so would it be correct to say that there are no scripts written for Proxy yet to do this?

Questions and Answers

6.6.1: In load balancing, how can I separate reads from writes?

There is no automatic separation of queries that perform reads or writes to the different backend servers. However, you can specify to [mysql-proxy](#) that one or more of the “backend” MySQL servers are read only.

```
shell> mysql-proxy \
--proxy-backend-addresses=10.0.1.2:3306 \
--proxy-read-only-backend-addresses=10.0.1.3:3306 &
```

6.6.2: How do I use a socket with MySQL Proxy? Proxy change logs mention that support for UNIX sockets has been added.

Specify the path to the socket:

```
--proxy-backend-addresses=/path/to/socket
```

6.6.3: Can I use MySQL Proxy with all versions of MySQL?

MySQL Proxy is designed to work with MySQL 5.0 or higher, and supports the MySQL network protocol for 5.0 and higher.

6.6.4: Can I run MySQL Proxy as a daemon?

Use the [--daemon](#) option. To keep track of the process ID, the daemon can be started with the [--pid-file=file](#) option to save the PID to a known file name. On version 0.5.x, the Proxy cannot be started natively as a daemon.

6.6.5: Will the proxy road map involve moving popular features from Lua to C? (For example, Read/Write splitting.)

We will keep the high-level parts in the Lua layer to be able to adjust to special situations without a rebuild. Read/Write splitting sometimes needs external knowledge that may only be available by the DBA.

6.6.6: Do proxy applications run on a separate server? If not, what is the overhead incurred by Proxy on the DB server side?

You can run the proxy on the application server, on its own box, or on the DB-server depending on the use case.

6.6.7: With load balancing, what happens to transactions? Are all queries sent to the same server?

Without any special customization the whole connection is sent to the same server. That keeps the whole connection state intact.

6.6.8: We have looked at using MySQL Proxy but we are concerned about the alpha status. When do you think the proxy will be considered production ready?

We are on the road to the next feature release: 0.9.0. It will improve the performance quite a bit. After that we may be able to enter the beta phase.

6.6.9: Is it possible to use MySQL Proxy with updating a Lucene index (or Solr) by making TCP calls to that server to update?

Yes, but it is not advised for now.

6.6.10: Is the system context switch expensive, how much overhead does the Lua script add?

Lua is fast and the overhead should be small enough for most applications. The raw packet overhead is around 400 microseconds.

6.6.11: How much latency does a proxy add to a connection?

In the range of 400 microseconds per request.

6.6.12: Do you have to make one large script and call it at proxy startup, can I change scripts without stopping and restarting (interrupting) the proxy?

You can just change the script and the proxy will reload it when a client connects.

6.6.13: If MySQL Proxy has to live on same machine as MySQL, are there any tuning considerations to ensure both perform optimally?

MySQL Proxy can live on any box: application, database, or its own box. MySQL Proxy uses comparatively little CPU or RAM, with negligible additional requirements or overhead.

6.6.14: Can MySQL Proxy be used on slaves and intercept binary log messages?

We are working on that. See <http://jan.kneschke.de/2008/5/30/mysql-proxy-rbr-to-sbr-decoding> for an example.

6.6.15: I currently use SQL Relay for efficient connection pooling with a number of Apache processes connecting to a MySQL server. Can MySQL Proxy currently accomplish this? My goal is to minimize connection latency while keeping temporary tables available.

Yes.

6.6.16: Are these reserved function names (for example, `error_result()`) that get automatically called?

Only functions and values starting with `proxy.*` are provided by the proxy. All others are user provided.

6.6.17: As the script is re-read by MySQL Proxy, does it cache this or is it looking at the file system with each request?

It looks for the script at client-connect and reads it if it has changed, otherwise it uses the cached version.

6.6.18: Given that there is a `connect_server()` function, can a Lua script link up with multiple servers?

MySQL Proxy provides some tutorials in the source package; one is [examples/tutorial-keepalive.lua](#).

6.6.19: Is the MySQL Proxy an API?

No, MySQL Proxy is an application that forwards packets from a client to a server using the MySQL network protocol. The MySQL Proxy provides a API allowing you to change its behavior.

6.6.20: The global namespace variable example with quotas does not persist after a reboot, is that correct?

Yes. If you restart the proxy, you lose the results, unless you save them in a file.

6.6.21: Can MySQL Proxy handle SSL connections?

No, being the man-in-the-middle, Proxy cannot handle encrypted sessions because it cannot share the SSL information.

6.6.22: Could MySQL Proxy be used to capture passwords?

The MySQL network protocol does not allow passwords to be sent in cleartext, all you could capture is the encrypted version.

6.6.23: Are there tools for isolating problems? How can someone figure out whether a problem is in the client, the database, or the proxy?

You can set a debug script in the proxy, which is an exceptionally good tool for this purpose. You can see very clearly which component is causing the problem, if you set the right breakpoints.

6.6.24: Can you explain the status of your work with [memcached](#) and MySQL Proxy?

There are some ideas to integrate proxy and [memcache](#) a bit, but no code yet.

6.6.25: Is MySQL Proxy similar to what is provided by Java connection pools?

Yes and no. Java connection pools are specific to Java applications, MySQL Proxy works with any client API that talks the MySQL network protocol. Also, connection pools do not provide any functionality for intelligently examining the network packets and modifying the contents.

6.6.26: So authentication with connection pooling has to be done at every connection? What is the authentication latency?

You can skip the round-trip and use the connection as it was added to the pool. As long as the application cleans up the temporary tables it used. The overhead is (as always) around 400 microseconds.

6.6.27: If you have multiple databases on the same box, can you use proxy to connect to databases on default port 3306?

Yes, MySQL Proxy can listen on any port, provided that none of the MySQL servers are listening on the same port.

6.6.28: What about caching the authorization information so clients connecting are given back-end connections that were established with identical authorization information, thus saving a few more round trips?

There is an `--proxy-pool-no-change-user` option that provides this functionality.

6.6.29: Is there any big web site using MySQL Proxy? For what purpose and what transaction rate have they achieved?

Yes, [gaiaonline](#). They have tested MySQL Proxy and seen it handle 2400 queries per second through the proxy.

6.6.30: How does MySQL Proxy compare to DBSlayer?

DBSlayer is a REST->MySQL tool, MySQL Proxy is transparent to your application. No change to the application is needed.

6.6.31: I tried using MySQL Proxy without any Lua script to try a round-robin type load balancing. In this case, if the first database in the list is down, MySQL Proxy would not connect the client to the second database in the list.

This issue is fixed in version 0.7.0.

6.6.32: Is it "safe" to use [LuaSocket](#) with proxy scripts?

You can, but it is not advised because it may block.

6.6.33: How different is MySQL Proxy from DBCP (Database connection pooling) for Apache in terms of connection pooling?

Connection Pooling is just one use case of the MySQL Proxy. You can use it for a lot more and it works in cases where you cannot use DBCP (for example, if you do not have Java).

6.6.34: MySQL Proxy can handle about 5000 connections, what is the limit on a MySQL server?

The server limit is given by the value of the `max_connections` system variable. The default value is version dependent.

6.6.35: Would the Java-only connection pooling solution work for multiple web servers? With this, I would assume that you can pool across many web servers at once?

Yes. But you can also start one proxy on each application server to get a similar behavior as you have it already.

6.6.36: Can you dynamically reconfigure the pool of MySQL servers that MySQL Proxy will use for load balancing?

Not yet, it is on the list. We are working on a administration interface for that purpose.

6.6.37: In the quick poll, I see "Load Balancer: read-write splitting" as an option, so would it be correct to say that there are no scripts written for Proxy yet to do this?

There is a proof of concept script for that included. But its far from perfect and may not work for you yet.