

# QoS Design overblik

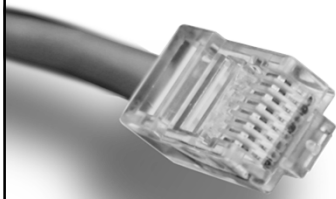

HOUSE OF  
TECHNOLOGY



- en del af **mercantec**<sup>+</sup>

QoS på L3

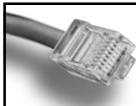

## Agenda

HOUSE OF  
TECHNOLOGY



- en del af **mercantec**<sup>+</sup>

- **Trafiktyper**
  - Voice
  - Best-Effort
  - ...
- **QoS principper**
  - Klassifikation og mærkning
  - Policing
  - Queing
  - ....



## Lidt forkortelser

- BE – Best Effort
  - Efter bedste evne
- AF – Assured Forwarding
  - Sikret overførsel (Trafik kan dog godt droppes)
  - Anvender lange køer
- EF – Expedited Forwarding
  - Express overførsel
  - Anvender korte køer
- CS – Class Selector



## IPv4 datagram (Service Type)

- Service Type inderholder 3 underfelter
  - Precedence
    - 3 Bits der beskriver pakkens prioritet på netværket.
    - Ej standardiseret (Men brugbar)
  - TOS: Type Of Service
    - **000: Normal service**
    - **100: Minimum forsinkelse**
    - **010: Maksimal gennemgang**
    - **001: Maksimal pålidelighed**
    - **Kan kombineres**
  - MBZ: Ikke brugt
    - Must Be Zero

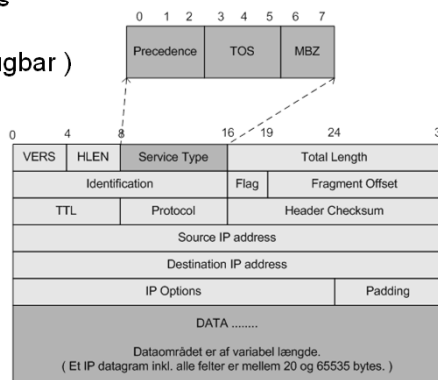



HOUSE OF TECHNOLOGY  
- en del af mercantec\*

## IP ToS felt eller DiffServ

### IP protokol header og datafelt (ver. 4)

Version nr. 4 bit Header længde 4 bit	Type af service 8 bit	Samlet pakke størrelse Incl. header 16 bit	Identifikation af datagram 16 bit	Flag 2 bit og fragment offset 13 bit	Time to live 8 bit	Angiver hvilken protokol der skal modtage pakken UDP eller TCP 8 bit	Header checks um 16 bit	Afsender IP adresse 32 bit	Modtager IP adresse 32 bit	Data felt Fra ca. 0,5 til 2Kbytes
------------------------------------------------	--------------------------	-----------------------------------------------	--------------------------------------	-----------------------------------------	-----------------------	----------------------------------------------------------------------------	----------------------------	-------------------------------	-------------------------------	--------------------------------------

Class Selector Codepoints (3 bit)	(3 bit)	Bruges ikke (2 bit)	<b>DiffServ</b>
	Drop Preference	Drop Preference	

Precedens bit (3 bit)	TOS subfelt (3 bit)	Bruges ikke (2 bit)	<b>IP TOS eller IP precedence</b>
	D    T    R		



HOUSE OF TECHNOLOGY  
- en del af mercantec\*

## Klassificering mellem DSCP og Service Type

Tabellen viser sammenhængen mellem DSCP og IP Precedence

IP Precedence	DSCP
Routine (IP Precedence 0)	0–7
Priority (IP Precedence 1)	8–15
Immediate (IP Precedence 2)	16–23
Flash (IP Precedence 3)	24–31 AF (Assured Forwarding)
Flash-override (IP Precedence 4)	32–39
Critical (IP Precedence 5)	40–47 EF (Expedited Forwarding)
Internet (IP Precedence 6)	48–55
Network (IP Precedence 7)	56–63



## DiffServ prioriteringsklasser



HOUSE OF TECHNOLOGY  
- en del af mercantec -

	Class 0	Class 1	Class 2	Class 3	Class 4	Class 5	Class 6	Class 7
<b>Class Selector</b>	000000 (CS0) Best Efford Data	001000 (CS1)	010000 (CS2)	011000 (CS3)	100000 (CS4) Stream video	101000 (CS5)	110000 (CS6) IP routing	111000 (CS7) network Manage
<b>Assured Forwarding</b> Low Drop Precedence		001010 (AF11)	010010 (AF21)	011010 (AF31) IP telefoni signaling	100010 (AF41) Video			
<b>Assured Forwarding</b> Medium Drop Precedence		001100 (AF12)	010100 (AF22)	011100 (AF32)	100100 (AF42)			
<b>Assured Forwarding</b> High Drop Precedence		001110 (AF13)	010110 (AF23)	011110 (AF33)	100110 (AF43)			
<b>Expedited Forwarding</b>						101110 (EF) IP voice		



## Cisco QoS Baseline



HOUSE OF TECHNOLOGY  
- en del af mercantec -

Applikations data	PHB	DSCP
IP Routing	CS6	48 – (110000)
Voice	EF	46 – (101110)
Interactive Video	AF41	34 – (100010)
Streaming Video	CS4	32 – (100000)
Mission-Critical	AF31	26 – (011010)
Call Signaling	CS3	24 – (011000)
Transactional	AF21	18 – (010010)
Network manage	CS2	16 – (010000)
Bulk	AF11	10 – (001010)
Scavenger	CS1	8 – (001000)
Best Effort	0	0 – (000000)



## Krav til VoIP

- Voice trafik mærkes DSCP EF
- Mindre end 1% pakketab
- Envejs forsinkelse mindre end 150 mS
  - Fra mund til øre
- Mindre end 30 mS Jitter
- 21 til 320 Kbps garanteret båndbredde
  - Afhænger af Codec og Lag 2 overhead
- Fast båndbredde (uden VAD)
  - Voice Activation Detection



## VoIP båndbredde – Uden lag 2

Codec	Pakke interval	Voice Payload	Pakker Sekund	Bånd-bredde
G.711	20 mS	160 Byte	50	80 Kbps
G.711	30 mS	240 Byte	33	74 Kbps
G.729A	20 mS	20 Byte	50	24 Kbps
G.729A	30 mS	30 Byte	33	19 Kbps







## VoIP båndbredde – med lag 2

HOUSE OF TECHNOLOGY  
  
...et af mercantec\*

Codec	PPS	Ethernet	PPP	ATM
G.711	50	93 Kbps	84 Kbps	106 Kbps
G.711	33	83 Kbps	77 Kbps	84 Kbps
G.729A	50	37 Kbps	28 Kbps	43 Kbps
G.729A	33	27 Kbps	21 Kbps	28 Kbps

20 Byte      8 Byte      12 Byte      20-240 Byte





## VoIP signalering

HOUSE OF TECHNOLOGY  
  
...et af mercantec\*

- Signalering mærkes DSCP CS3
  - Indtil videre er DSCP AF31 anvendt
- Cirka 150 bps + Lag 2 overhead
  - Afhænger af signalerings protokol (SIP, SCCP)
  - Alloker 5% af båndbredde til signalering
- Signaleringsprotokoller anvender forskellige TCP og UDP porte
  - SIP, SCCP, H.225, H.245, MGCP
  - Derfor ingen standard løsning for alt VoIP



## Video konference (IP/VC)

- Mærkes DSCP AF41
- Mindre end 1% tab
- Envejs forsinkelse mindre end 150 mS
  - Fra mund til øre
- Mindre end 30 mS Jitter
- Variable pakkestørrelser
- Variable pakkeintervaller



## Streaming Video

- Mærkes DSCP CS4
- Mindre end 5% tab
- Forsinkelse mindre end 4-5 sekunder
  - Afhænger af modtagerens buffer
- Ingen generelle Jitter krav
- Båndbredde afhænger bla. Af Codec
- Oftest envejs kommunikation



## Data - problemet

- Mange hundrede tusinde applikationer
  - Hver applikation har sin egen profil
- Forskellige krav til forskellige applikationer
  - Delay, Jitter, båndbredde, pakkestørrelser....
- Forskellige versioner af samme applikation
  - Opgradering af applikation kan give anden trafik
  - Og dermed ødelægge QoS i virksomheden
- QoS uoverskueligt på denne måde



## Data – en løsning

- Definer fire data klasser
  - Best-Effort data
    - Standard klasse for al trafik mærkes DSCP 0
  - Bulk Data
    - FTP, e-mail, backup mærkes DSCP AF11
  - Transactional / Interactive data
    - Databaseopslag, Citrix, telnet mærkes DSCP AF21
  - Lokal bestemt Mission Critical Data
    - For eksempel SAP mærkes DSCP AF31





## Scavanger class

- For blandt andet at bekæmpe virus
- Trafik der ikke relaterer til arbejde
  - KaZaa, Morpeus, Napster, Doom, Quake..
- anbefales tildelt 1% af båndbredde
- Scavanger trafik mærkes DSCP CS1





## Lidt forvirring gennem tiderne

4/5 Klasse model

8 Klasse model

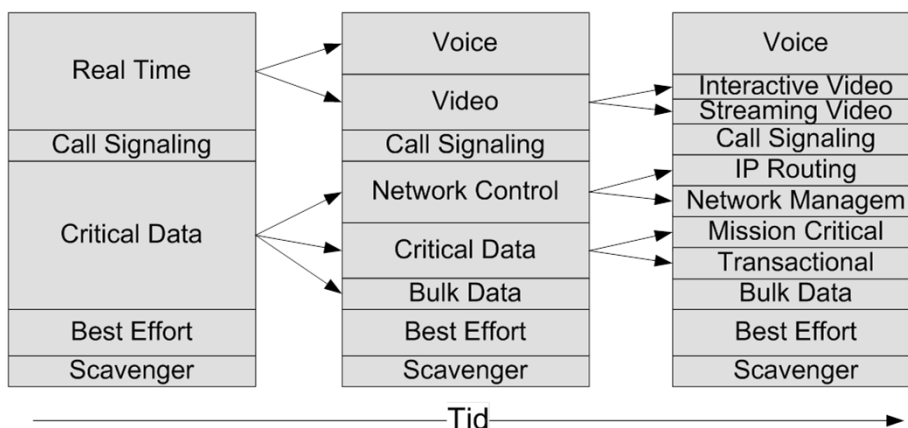
QoS Baseline model







## Cisco QoS Baseline – 11 klasser

HOUSE OF TECHNOLOGY  
  
— a division of mercantec\*

Applikations data	PHB	DSCP	TOS
IP Routing	CS6	48 – (110000)	192
Voice	EF	46 – (101110)	184
Interactive Video	AF41	34 – (100010)	136
Streaming Video	CS4	32 – (100000)	128
Mission-Critical	AF31	26 – (011010)	104
Call Signaling	CS3	24 – (011000)	96
Transactional	AF21	18 – (010010)	72
Network manage	CS2	16 – (010000)	64
Bulk	AF11	10 – (001010)	40
Scavenger	CS1	8 – (001000)	32
Best Effort	0	0 – (000000)	0



## Klassifikation og mærkning

HOUSE OF TECHNOLOGY  
  
— a division of mercantec\*

- Klassificer
  - Identificer hvilken klasse en pakke tilhører
- Mærkning
  - Når pakken er identificeret mærk den med for eksempel DSCP
- Bør gøres så tæt på afsender som muligt
- Tør vi tro på den mærkning en PC laver?
- Anvend DSCP hvor muligt
  - DSCP fremføres End-to-End



## Policing og Markdown

- Policing
  - Sætte grænser for hvor meget trafik der behandles
- Markdown
  - Hvis der kommer mere trafik end Policen
  - Ændre DSCP på excess trafik til mindre prioritet
  - For eksempel AF31 til AF32 eller AF33
- Ved eventuel congestion droppes flere AF32 end AF31
- Standardiserede regler: RFC 2597



## Queing og Drop principper

- For at give VoIP service garanti
  - Trafik lægges i kø midlertidigt
  - Trafikmængden pulserer, køer glatter ud.
- Der er mulighed for Congestion alle steder hvor der er forskellige hastigheder ind og ud.
- Tommelfinger regler
  - Reserver 25% af båndbredde til Best Effort
  - Hvis real-time trafik overstiger 33% stiger ventetiden på alt andet trafik voldsomt.

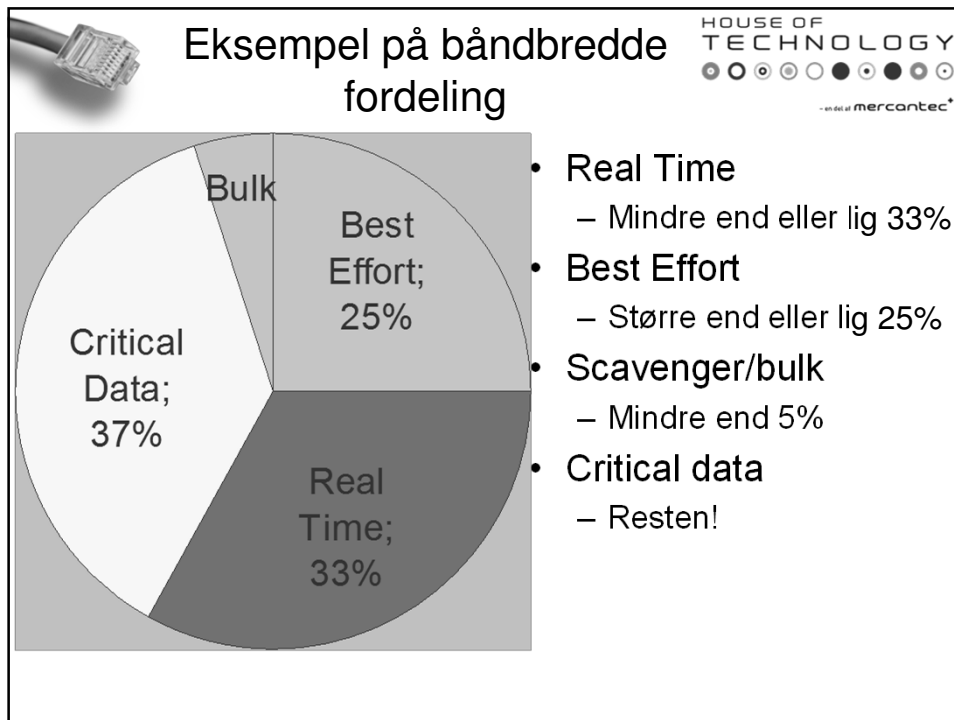

- Opgave**
- HOUSE OF TECHNOLOGY  
  
© 2004 mercantec\*
- Påvis i Wireshark at Telefonerne bliver markeret rigtigt.
  - Find DSCP markeringerne for
    - Samtale trafik
    - Signalerings trafik
  - Find CoS markeringen for
    - Samtale trafik
    - Signalerings trafik
  - Lav et dokument der beskriver markeringen, og find nogle referencer til hvilke markeringer der skal bruges(cisco.com)