

Network

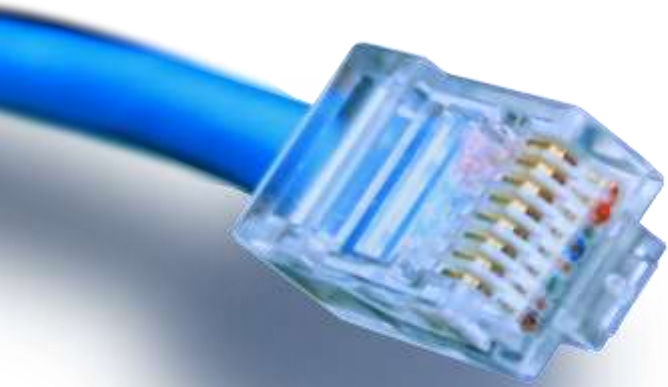

HOUSE OF
TECHNOLOGY



- en del af **mercantec**⁺

Netværks design

Region Syd Grundlæggende netværk



Emner

- Egenskaber ved netværks design
- 3 lags modellen



Design Principer

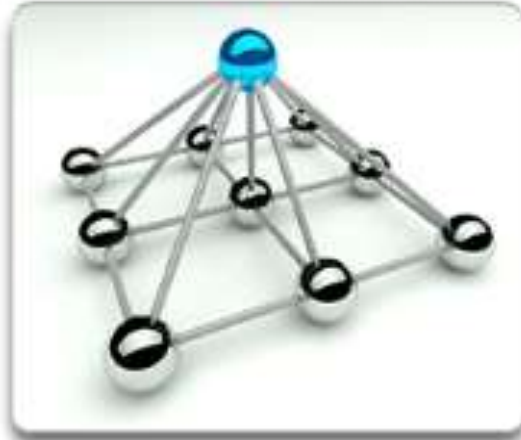

Hierarchy



Modularity



Resiliency



Flexibility



Design Principer

- Hierarki
 - 3 lags model – Core, Distribution, Access
- Access
 - Bruger tilslutninger
- Distribution
 - Sikkerhed
- Core
 - Hurtig transport

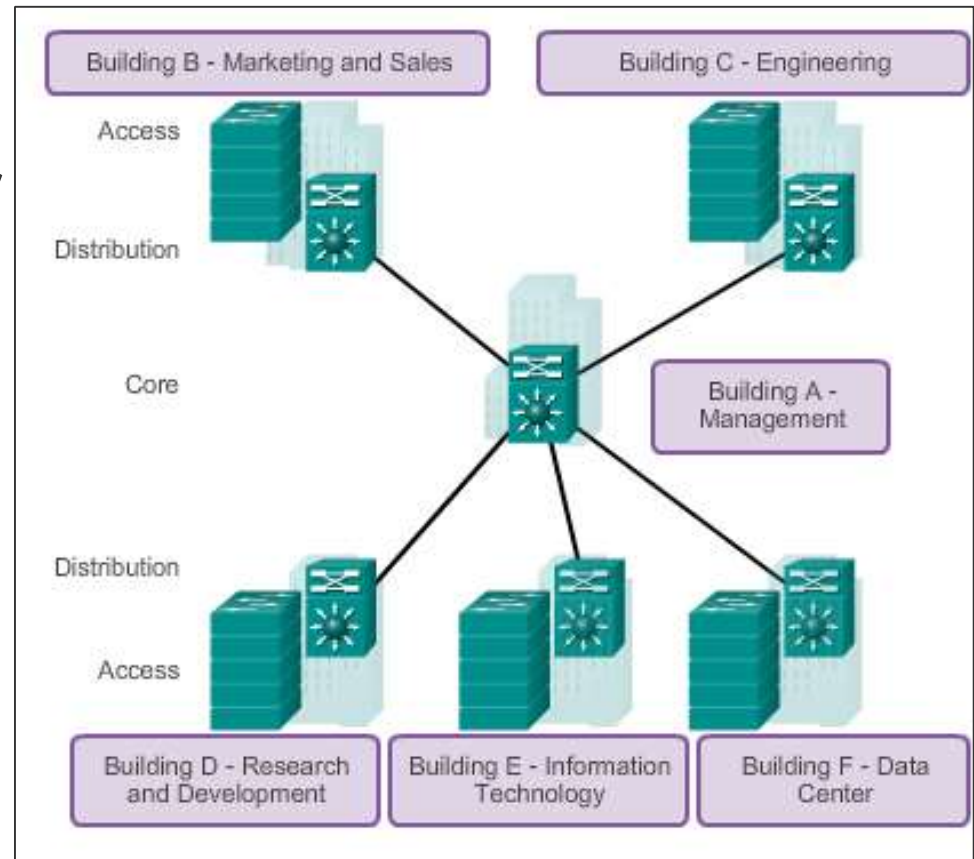



Access laget

- L2 Switching
- High availability
- Port sikkerhed*
- QoS markering
- ARP Sikkerhed*
- Spanning Tree*
- Power over Ethernet

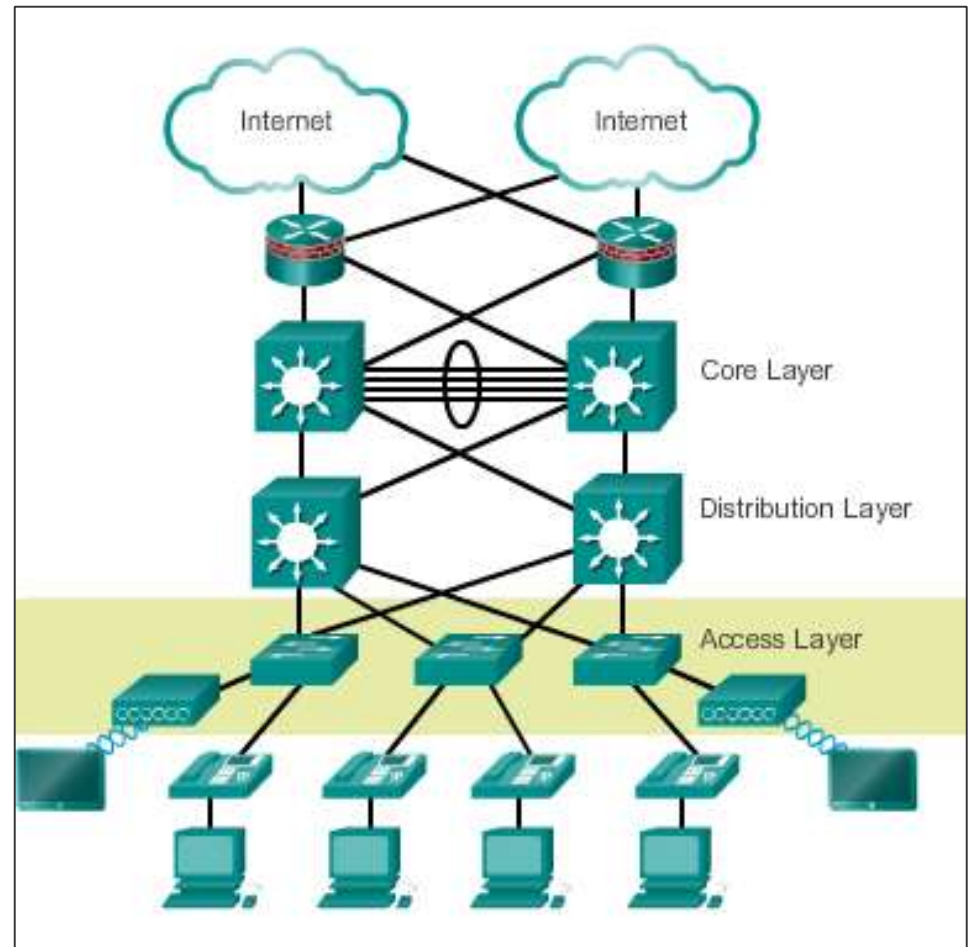



Distributions laget

- Forbinder Access med Core
- Gateway for klienter
- Politik baseret sikkerhed
- Redundans og load balancing

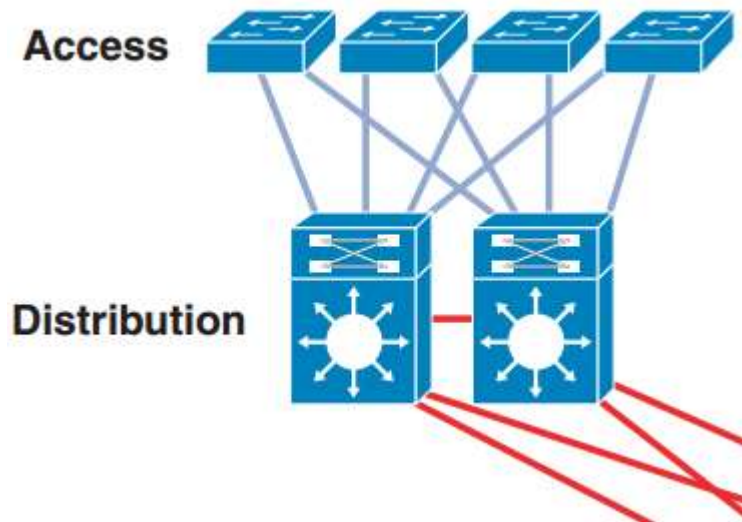



Core laget



- Forbinder alle distributions lagene
- Flytter pakker lyn hurtigt
- Ingen pakke manipulation
- Redundans og load balancing

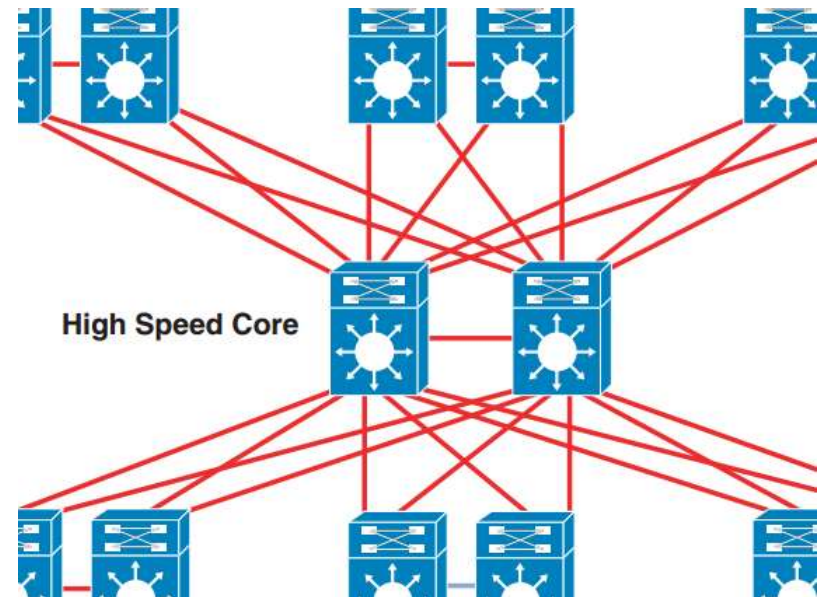



Modularitet

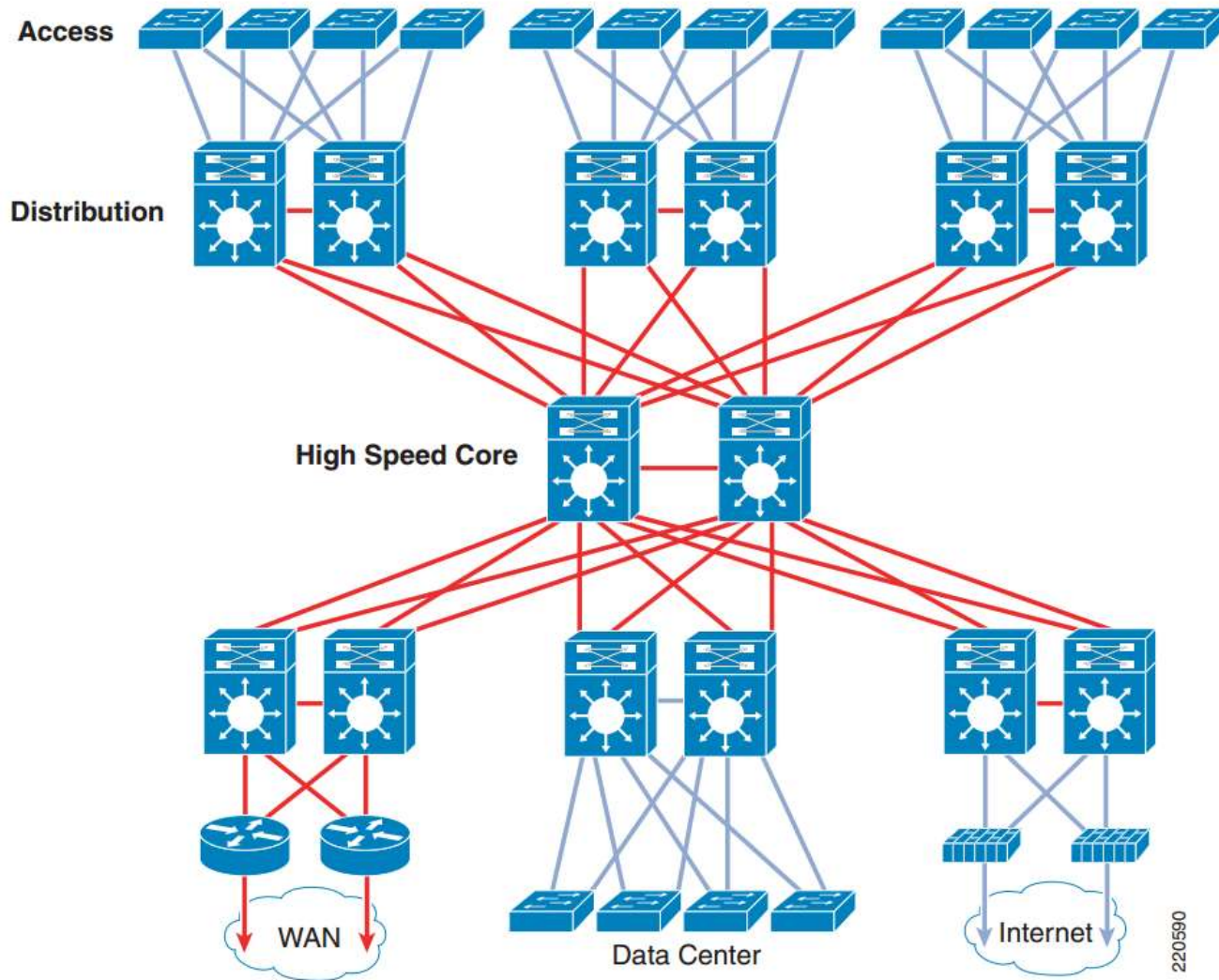



Resiliency

- Modstandskraft overfor uforudsete hændelser
 - Strøm afbrydelse
 - UPS/generator
 - Kabel fejl
 - Redundante linjer
 - Hardware fejl
 - Redundante enheder
 - PSU, RAM, netkort

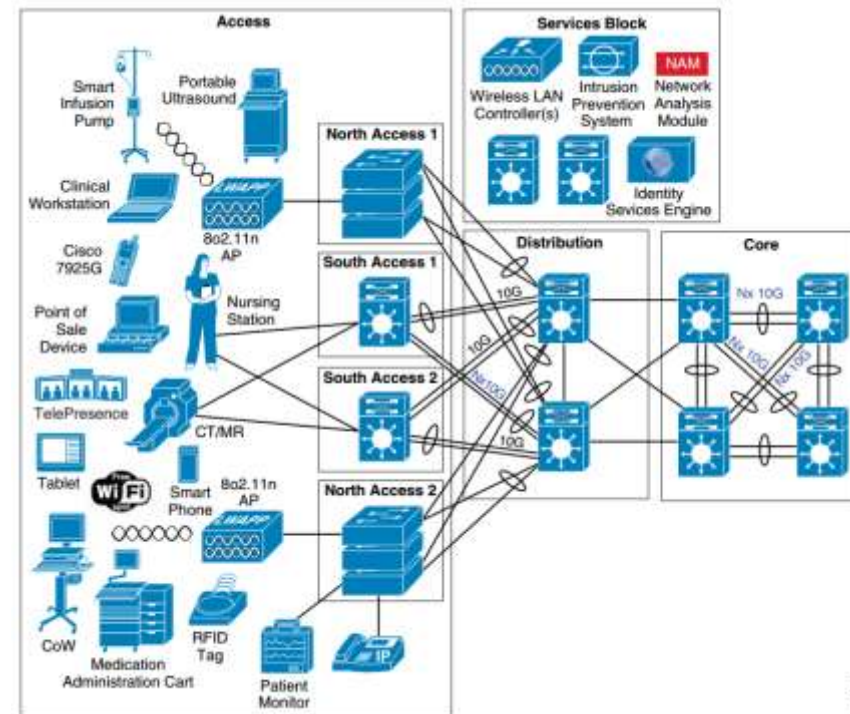



Resiliency



- Single point of failure(SPOF)
 - Forsøg altid at udgå SPOF i alle systemer
 - Redundant udstyr
- Nedetid
 - Mean Time to Repair
 - Mean Time Between Failure
- For meget redundans
 - RTO bliver for lavt
 - Komplexiteten stiger
 - Fejlfinding bliver sværere

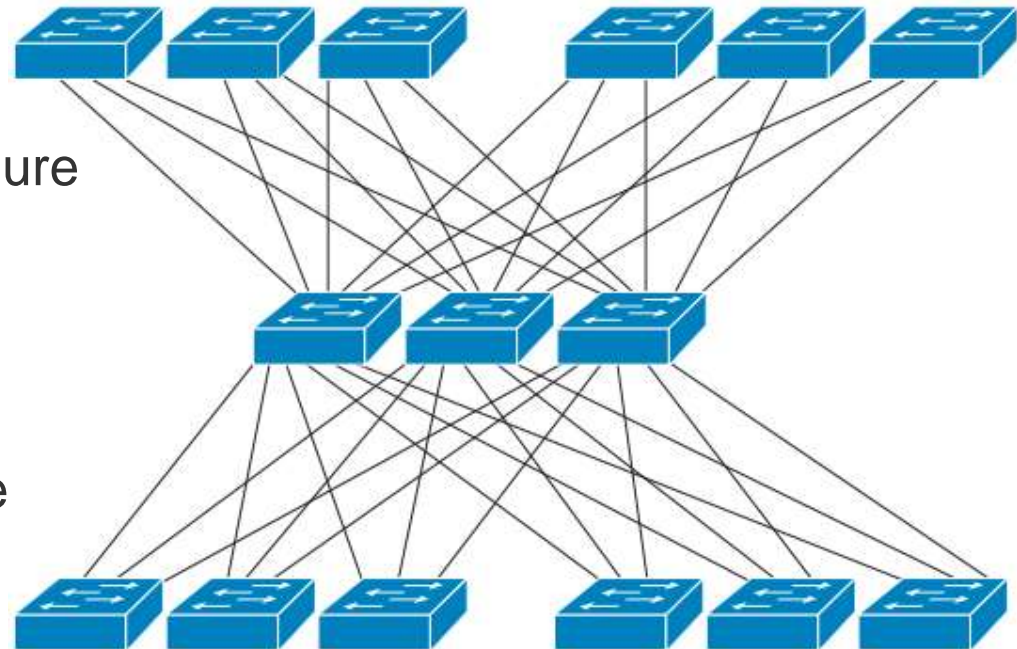



Flexibility

- Netværket skal være i stand til at tilpasse sig nye krav.
 - Voice/Video
 - Collaboration
 - Bring Your Own Device(BYOD)
 - Internet of Everything(loE)

Netværks Typer



HOUSE OF
TECHNOLOGY



- en del af **mercantec**⁺

Netværks design

Region Syd Grundlæggende netværk



Netværks Typer

- Lidt netværks termer.
 - Personal Area Network(PAN)
 - Inden for et lille geografisk område
 - Local Area Network(LAN)
 - Inden for et begrænset geografisk område
 - Metropolitan Area Network(MAN)
 - Inden for by grænsen
 - Wide Area Network(WAN)
 - På tværs af byer, stater og lande
- Ingen sammenhæng med teknologier



Netværks Typer

- Personal Area Network(PAN)
 - Forbinder enheder indenfor få meter
 - Bruges bl.a. til udveksling af filer
 - Infrared Data Association(IrDA)
 - Infrarød lys til at forbinde fx telefon og computer
 - Bluetooth(IEEE 802.15)
 - 2,4 GHz wireless til at forbinde enheder
 - Fil overførsel, headset, fjernstyring



Bluetooth[®]



Netværks Typer



- Local Area Network(LAN)
 - Forbinder enheder indenfor samme bygning/Campus
 - Det vi kender som hjemme netværk/virksomhedens netværk
 - Token Ring(IEEE802.5)
 - Coaxial kabel
 - Ethernet (IEEE 802.3)
 - Kablet netværk til at forbinde enheder
 - Kobber - Twisted Pair kabling
 - Fiber – Multimode, Singlemode
 - Wireless Ethernet (IEEE 802.11)
 - Enheder forbindes via trådløse signaler.





Netværks Typer

- Metropolitan Area Network(MAN)
 - Forbinder bygninger/Campus'er indenfor en bygrænse
 - Virksomheder kan have sine egne MAN's eller leje sig ind hos en Service Provider
 - MPLS netværk
 - Kan bruges både som MAN og WAN
 - Metro Ethernet
 - En SP har Ethernet på fiber rundt i hele byen

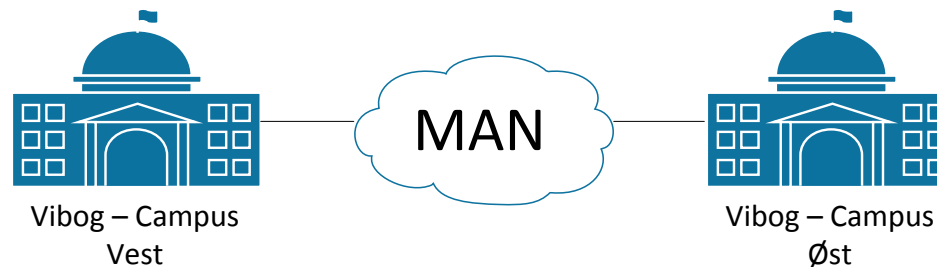



Netværks Typer

- Wide Area Network(WAN)
 - Forbinder bygninger/Campus'er på tværs af landet eller lande
 - Virksomheder køber som regel forbindelser hos en Service Provider
 - Ældre protokoller:
 - ATM
 - Frame-Relay
 - ISDN
 - MPLS netværk
 - Kan bruges både som MAN og WAN





Netværks Typer

- MultiProtocol Label Switching
 - Bruges af de fleste udbydere til at tilbyde WAN forbindelser
 - Understøtter at ligge på mange forskellige protokoller(ATM, Ethernet, osv.)
 - Understøtter forskellige protokoller ovenpå(IPv4/IPv6/Ethernet)
 - Adskiller kunderne med logiske Labels

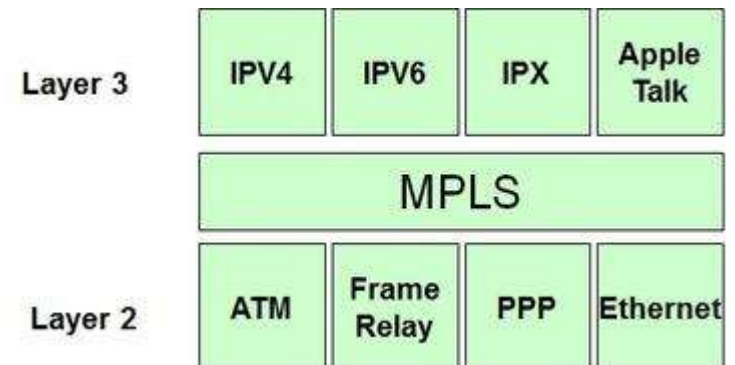
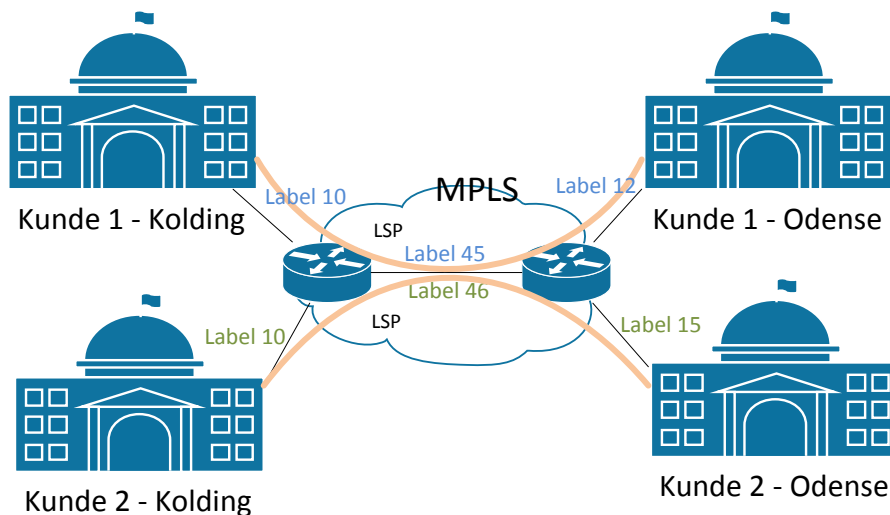



Netværks Typer



- Netværks typerne interfacer med hinanden igennem gateways

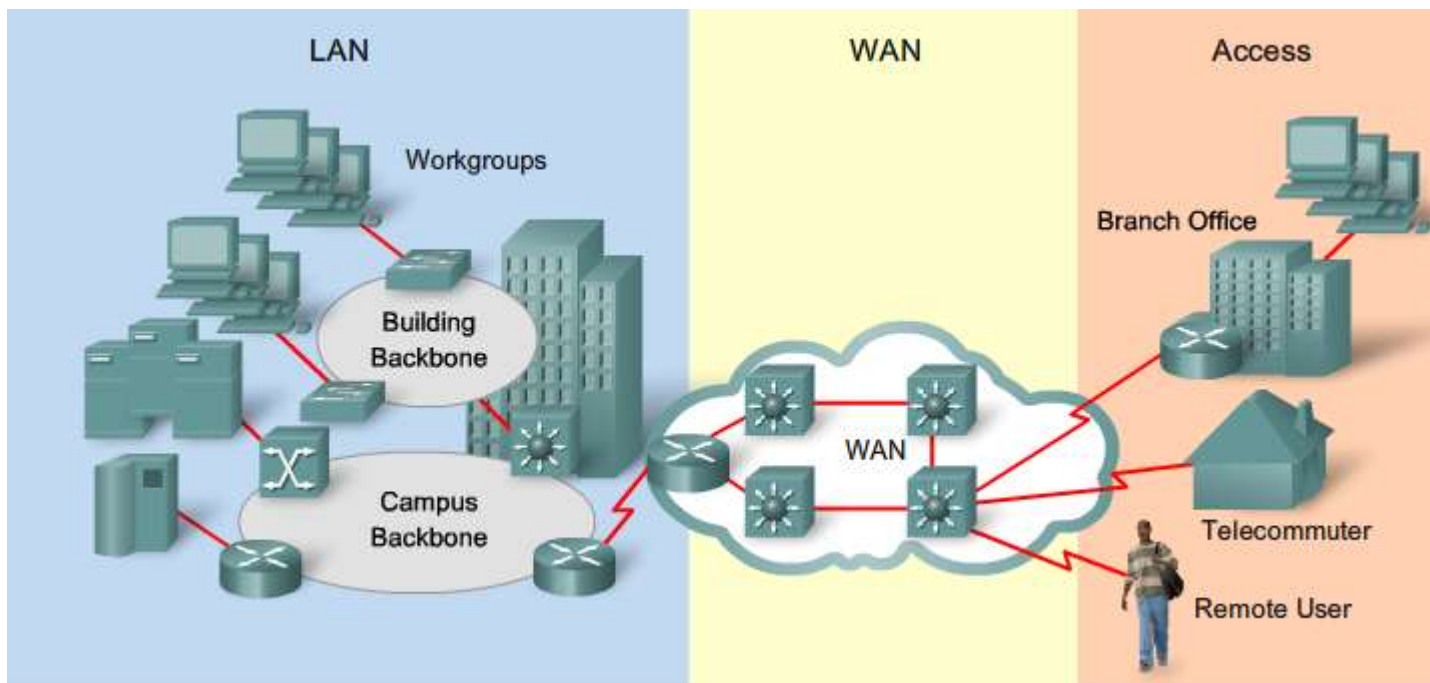



Netværks Typer

- Netværks typerne interfacer med hinanden igennem gateways

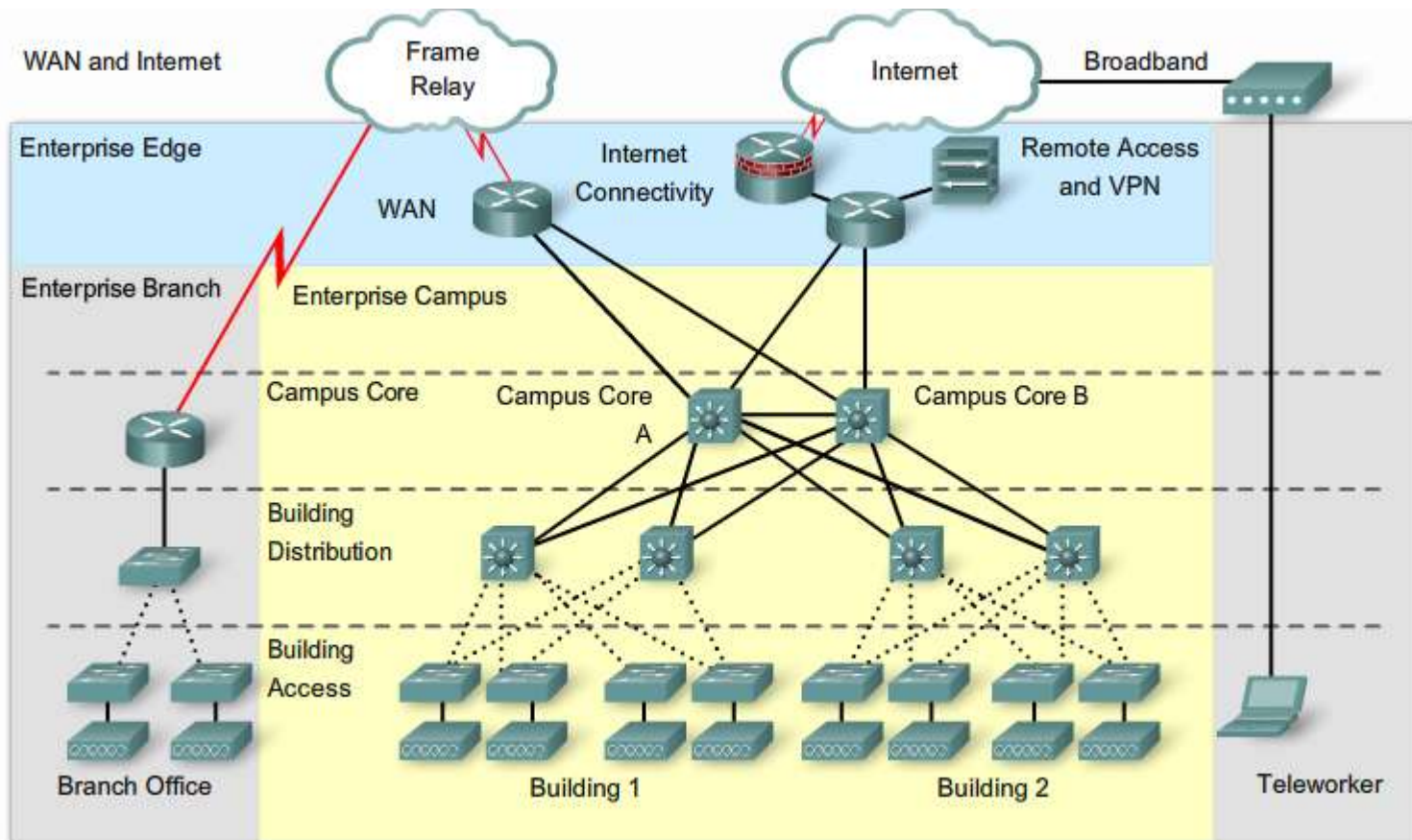

Netværks Egenskaber

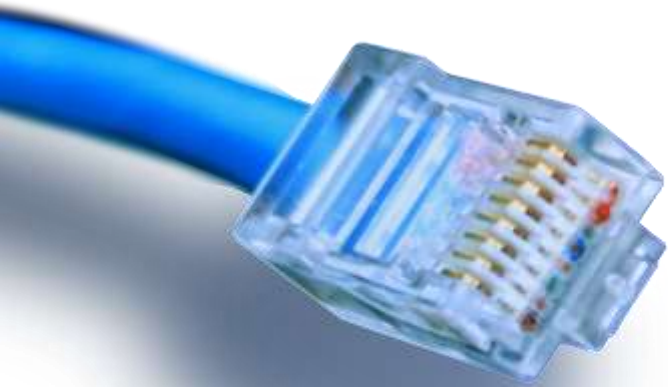

HOUSE OF
TECHNOLOGY



- en del af **mercantec**⁺

Netværks design

Region Syd Grundlæggende netværk



Netværks Egenskaber

- **Hastighed**
 - Transmissions hastigheder
 - Hvor meget data kan overføres pr. sekund
- **Forsinkelse**
 - Transmissions tiden
 - Hvor lang tid tager det at flytte en pakke
- **Jitter**
 - Den variable forsinkelse
 - Forskellen i forsinkelse på flere pakker
- **Pakketab**
 - Transmissions tabet
 - Hvor mange pakker kommer ikke igennem



Hastighed

- Hastigheden måles i bits pr. sekund
- 1 bit er den mindste dataenhed vi har
 - Kan være 0 eller 1
- En 10 Mbit/s forbindelse kan altså overføre en million bit i sekundet.
- Måles på mediet*
- 1 Byte består af 8 bit





Forsinkelse



- Den tid det tager at flytte en pakke på tværs af netværket.
- Kaldes også Delay, Latency
- Den totale forsinkelse inkluderer processing, serialization, propagation, queuing

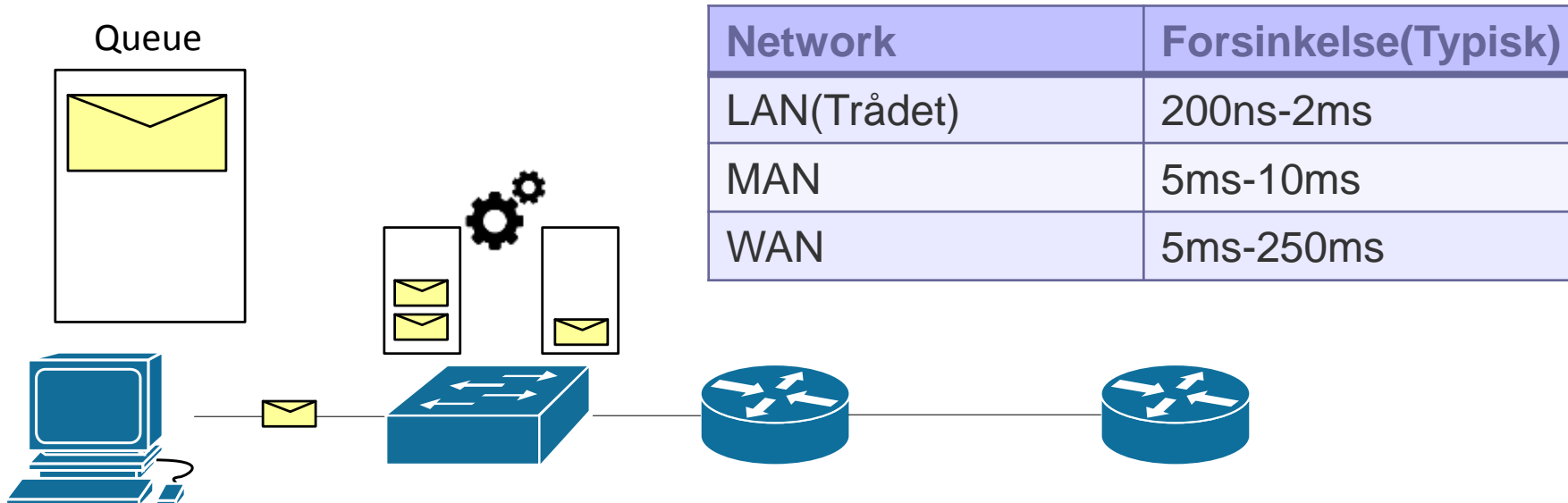



Jitter



- Beskriver den variation i forsinkelse pakker har.
- Et netværk med et delay på 100ms kan godt have jitter på 0ms.
- Jitter kan være skadeligt for streaming applicationer(Voice/TV)

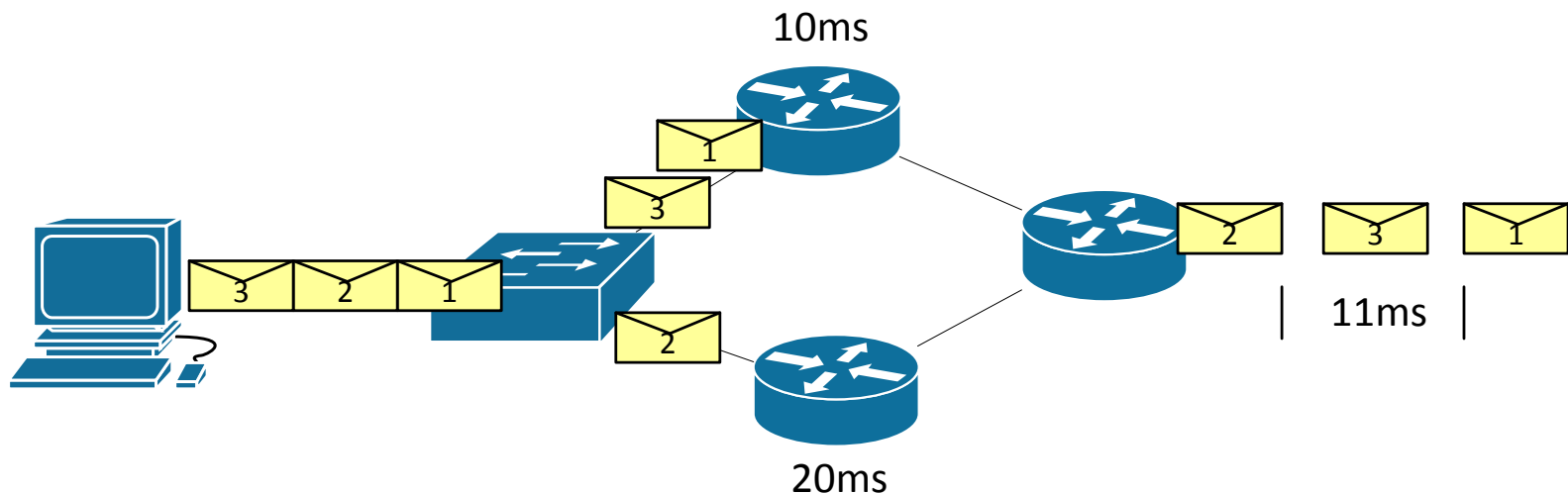



Pakketab



- Det antal pakker der "forsvinder" i netværket.
- Pakkettab kan skyldes
 - Overbelastning
 - Fejlbehæftet udstyr
 - Defekte stik/Kabler
- Angives i procent eller Pakker pr. million
- Nogle protokoller gensender tabte pakker

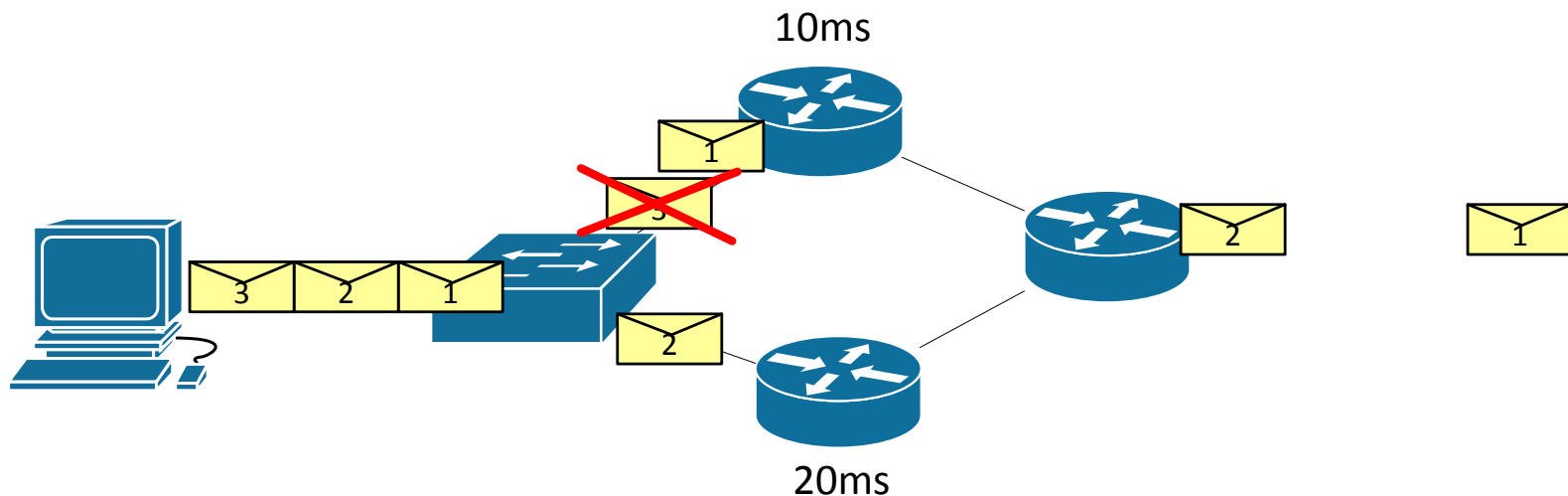



Netværk



- Når man sætter alle parametre sammen har de indflydelse på hinanden.
- Alm. trafik varierer meget, når der pludseligt kommer mange pakker, gemmes de i køer i håb om at kunne sende senere. – Delay & Jitter
- Hvis der stadig kommer for meget trafik når køen er fuld, smides pakker væk – Pakketab
- Det er ganske normalt at have delay, jitter og pakketab

