

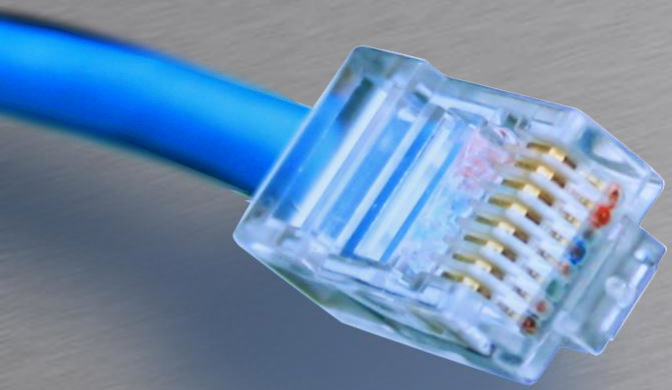

# IP Telefoni



HOUSE OF  
TECHNOLOGY



- en del af **mercantec**<sup>+</sup>

DHCP Options  
VLANs



# Understanding the Cisco IP Phone Boot Process

- The Cisco IP Phone connects to an **Ethernet switchport**. If the IP phone and switch support PoE, the IP phone receives power through either Cisco-proprietary PoE or 802.3af PoE.
- As the Cisco IP Phone powers on, the Cisco switch delivers **voice VLAN information** to the IP phone using CDP as a delivery mechanism. The Cisco IP Phone now knows what VLAN it should use.
- The Cisco IP Phone sends a **DHCP request** asking for an **IP address** on its voice VLAN.
- The DHCP server responds with an IP address offer. When the Cisco IP Phone accepts the offer, it receives all the DHCP options that go along with the DHCP request. DHCP options include items such as **default gateway, DNS server information, domain name information**, and so on. In the case of Cisco IP Phones, a unique DHCP option is included, known as **Option 150**. This option directs the IP phone to a TFTP server.
- After the Cisco IP Phone has the **IP address of the TFTP server**, it contacts the TFTP server and downloads its configuration file.
- The Cisco IP Phone attempts to contact the first call processing server (**the primary server**) listed in its configuration file to register. If this fails, the IP phone moves to the next server in the configuration file. This process continues until the **IP phone registers** successfully or the list of call processing agents is exhausted.





# DHCP (Dynamic Host Configuration Protocol)

- En DHCP servers funktion er at styre og konfigurere TCP/IP opsætningen på computere/klienter som anmoder om det.
- DHCP serveren letter det administrative arbejde betydeligt, idet der ikke manuelt tildeles IP adresser mv.
- Desuden kan den samme adresse ikke lejes ud 2 gange på samme tid, dvs. at man ikke kan få adresse konflikt.
- En DHCP server kan konfigurere DHCP klienter med mange forskellige parametre som fx:
  - En IP adresse
  - Subnet maske
  - Gateway adresse
  - Adressen på en eller flere DNS servere
  - WINS servere,
  - proxy server osv.

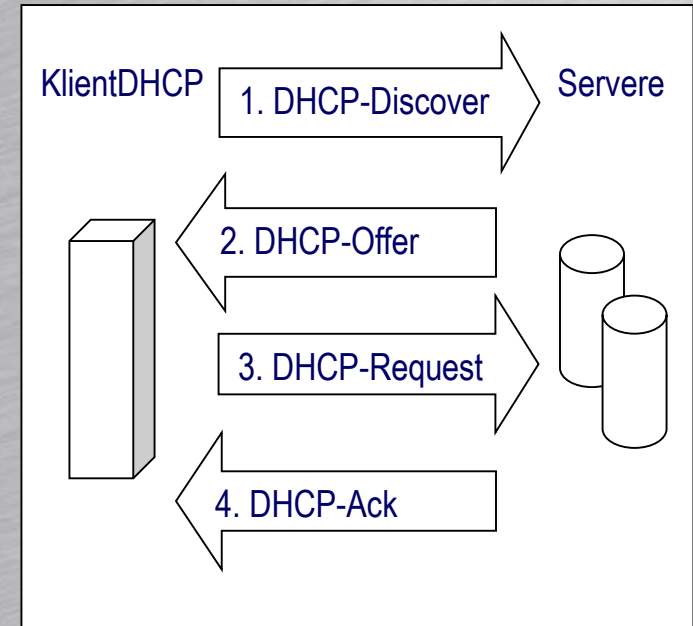



# DHCP (Dynamic Host Configuration Protocol)

- **DHCP-Discover**
  - Klient anmoder om konfiguration fra en DHCP-server
- **DHCP-Offer**
  - Servere tilbyder IP-adresse og øvrige standard opsætninger
- **DHCP-Request**
  - Klient vælger server og bekræfter de parametre serveren leverede
- **DHCP-Ack**
  - Serveren accepterer valget

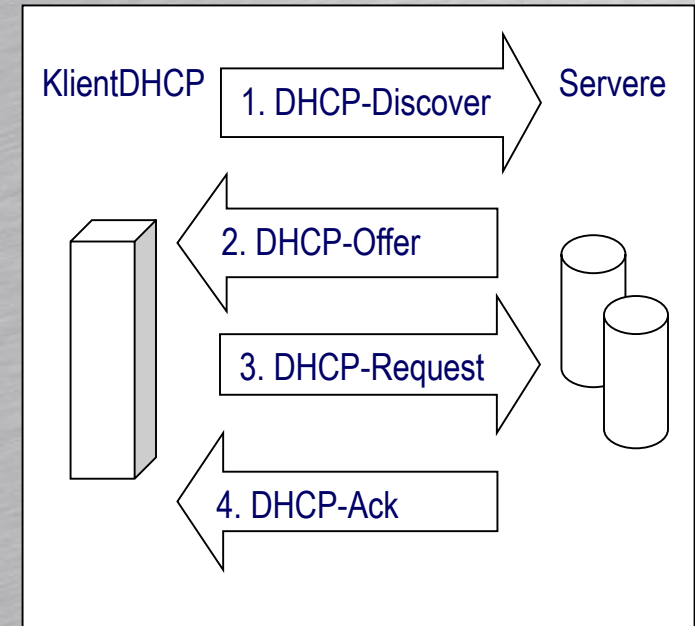



# DHCP example

**DHCP lease pool on server:**  
IP address range: 194.182.53.10 - 194.182.53.199  
Subnet mask: 255.255.255.0  
DNS server: 192.71.13.54  
Default gateway: 194.182.53.1

DHCP Client

DHCP Client

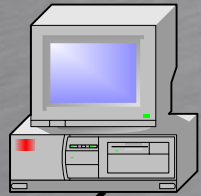

Net: 194.182.53/24

1

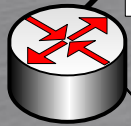

3

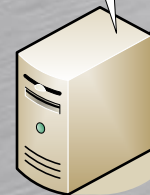

DHCP Server  
Static IP address



Internet

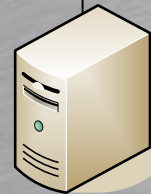

DNS server  
192.71.13.54

ROUTER

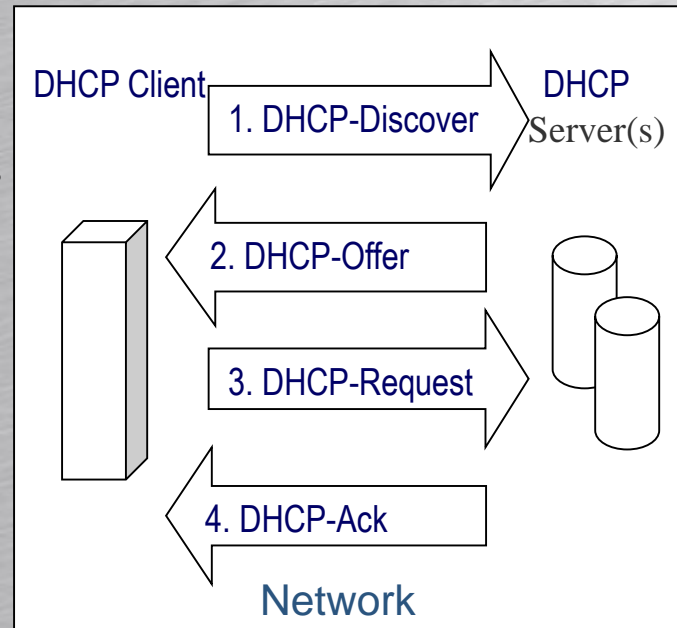



# DHCP options

- Windows DHCP server options configuration example
- TFTP servers are often used to store IP phones configuration files.

172.16.4.66 - Remote Desktop Connection

Option Name	Vendor	Value	Class
003 Router	Standard	172.16.4.19	None
015 DNS Domain Name	Standard	tekkom.local	None
121 Classless Static Routes	Standard	192.168.139.0, 255.255.255.0, 172.16.4.19	None
<b>150 TFTP</b>	Standard	192.168.139.88	None
004 Time Server	Standard	172.16.4.16	None
006 DNS Servers	Standard	172.16.4.66	None
042 NTP Servers	Standard	172.16.4.16	None
066 Boot Server Host Name	Standard	fog.tekkom.dk	None
067 Bootfile Name	Standard	pxelinux.0	None



# IP TELEPHONY AND VOICE VLAN

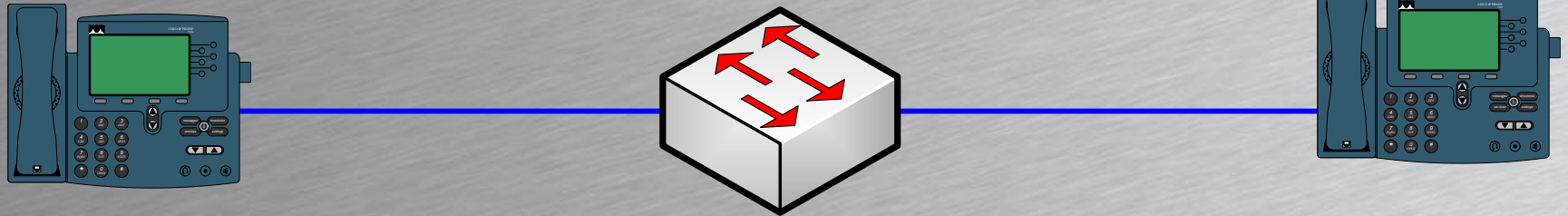



# IP Telephony

In a normal voice call 50 packets per second is sent in each direction. One packet each 0.02 second

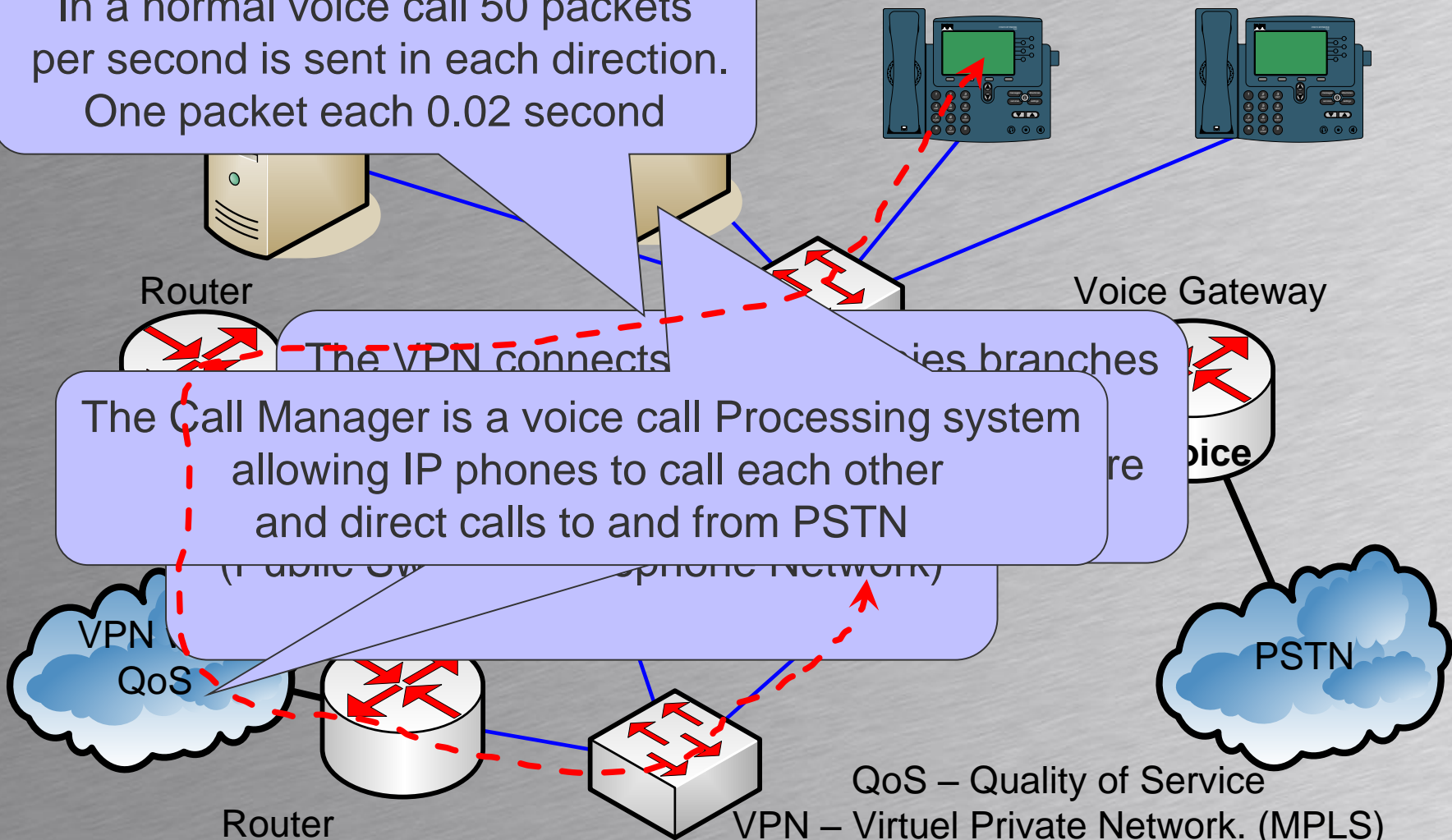

The Call Manager is a voice call Processing system allowing IP phones to call each other and direct calls to and from PSTN

The VPN connects...ies branches

QoS – Quality of Service  
VPN – Virtual Private Network. (MPLS)  
PSTN – Public Switched Telephone Network





# IP Telephony

- IP telephony is an instant service
  - Voice packet stream between phones
    - Normaly 50 packets per second
- To ensure good voice quality, voice packets should be transferred between phones
  - With low delay (  $< 150\text{mS}$ )
  - With little jitter ( $< 30\text{mS}$ )
    - Jitter is variable delay between packets in
  - With little packet loss ( $< 1\%$ )



# IP Telephony

- VoIP best practice is separating voice and data traffic in the network
  - Enhancing security not mixing VoIP and data
  - Troubleshooting simplified
  - Easier to deploy Quality of Service
- Two ways of separating data and voice
  - Two physical networks
  - One physical network with separate VLAN's for voice and data



# IP Telephony

- Two physical networks
  - Expensive
    - 2 x Devices, 2 x cabling and 2 x VPN's
  - Easy to ensure good voice quality
- One physical network
  - Two logical networks – one for voice one for data
    - Using a data-VLAN and a voice-VLAN
  - Cheaper
  - More difficult to ensure voice quality
    - Need end-to-end quality of service configured



# VLAN Review

## Virtual Local Area Network

- Switch ports belong to a VLAN
- Devices on same VLAN can communicate
- Switch ports configured as trunks can exchange VLAN traffic between switches

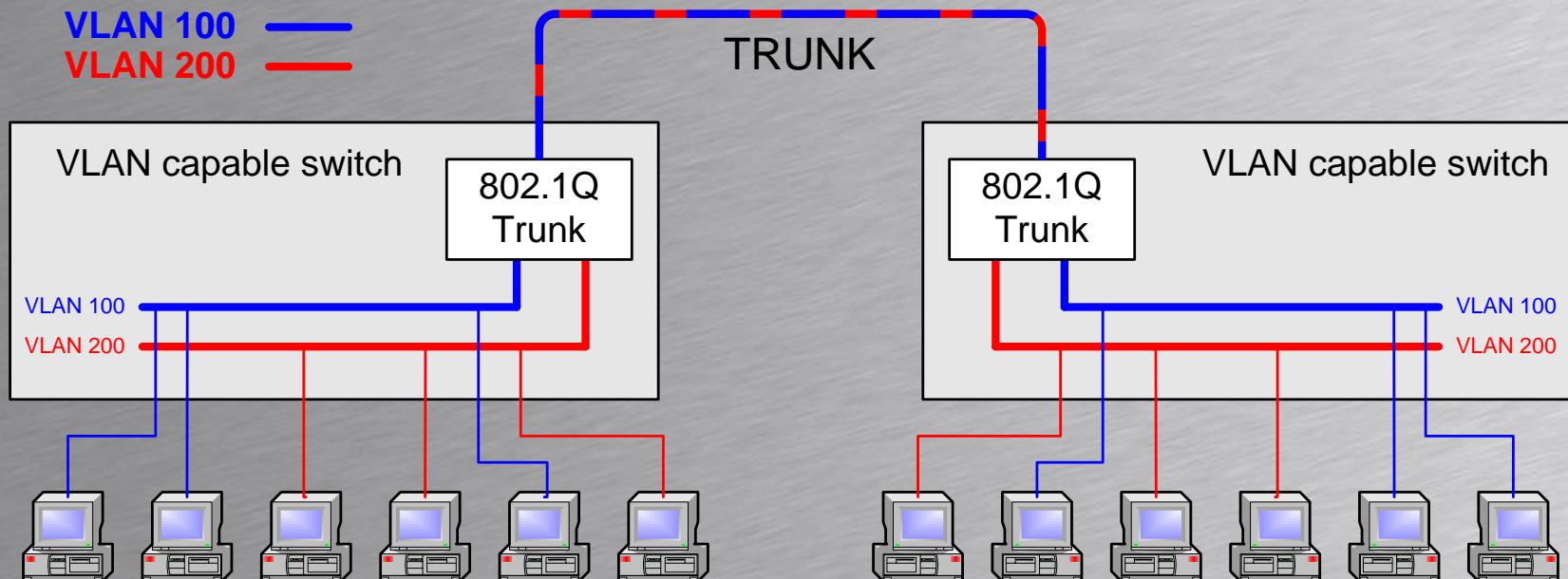



# Voice VLAN option 1

- Traffic separated physically between switch and users desk
  - One cable and one switch port for users PC
  - One cable and one switch port for users IP Phone
  - Expensive in cabling and switches

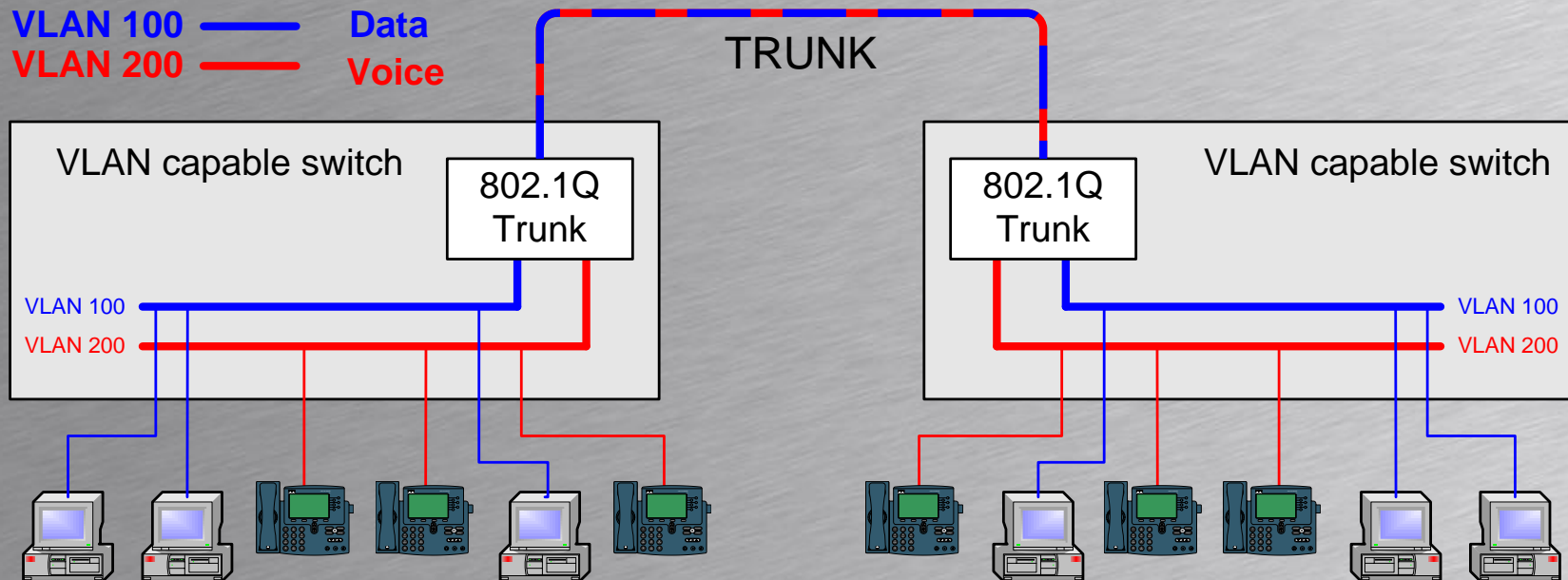



# Voice VLAN option 2

• ...ly between switch and

IP phone ethernet port connects to Switch in rack closet typically through RJ45 wall plug.

• US

ability

• Bu

one

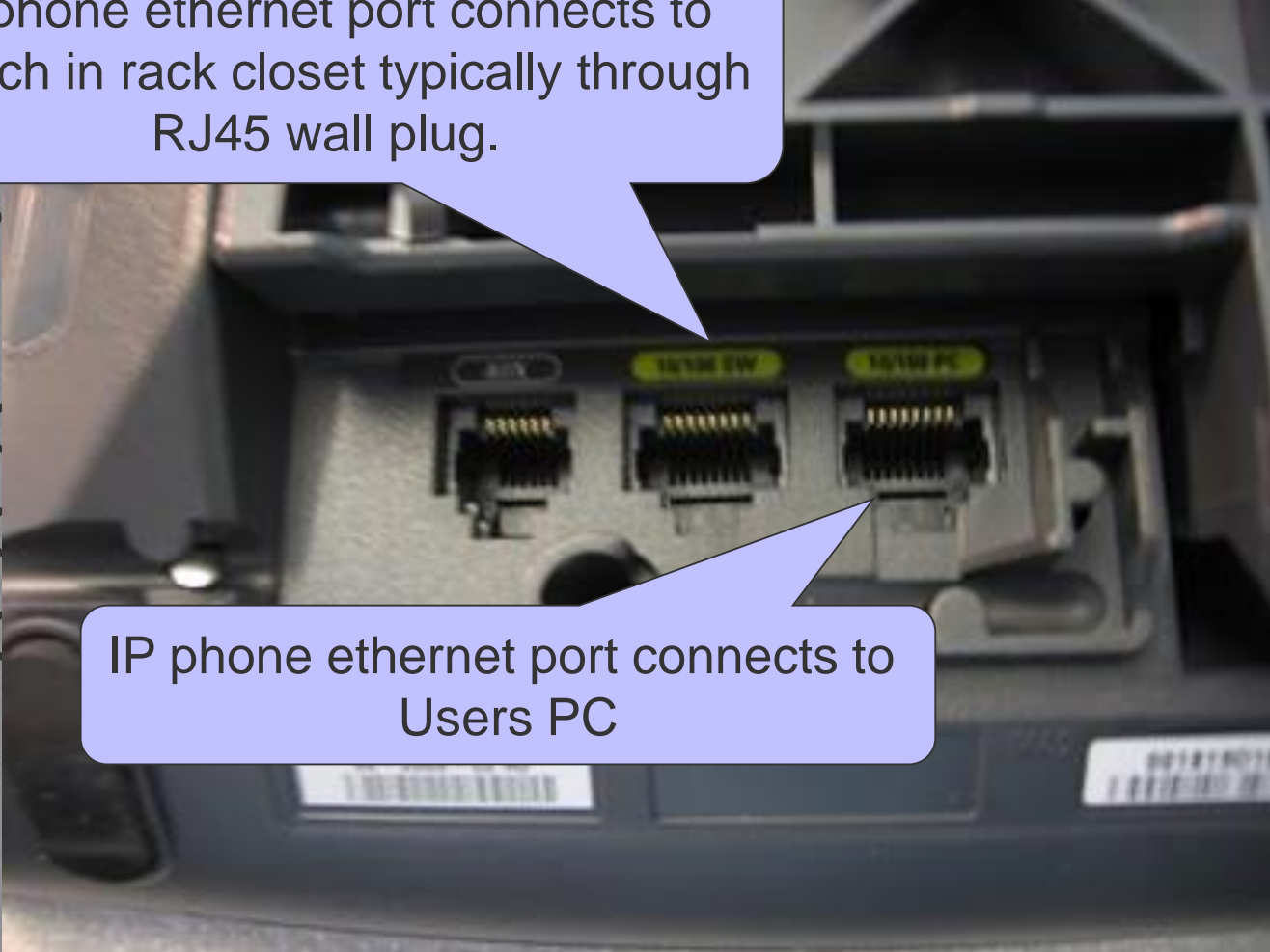

IP phone ethernet port connects to Users PC

- (
- (
- (

phone it self

the PC



# Voice VLAN option 2

- Data traffic carried in VLAN 100
- Voice traffic carried in VLAN 200

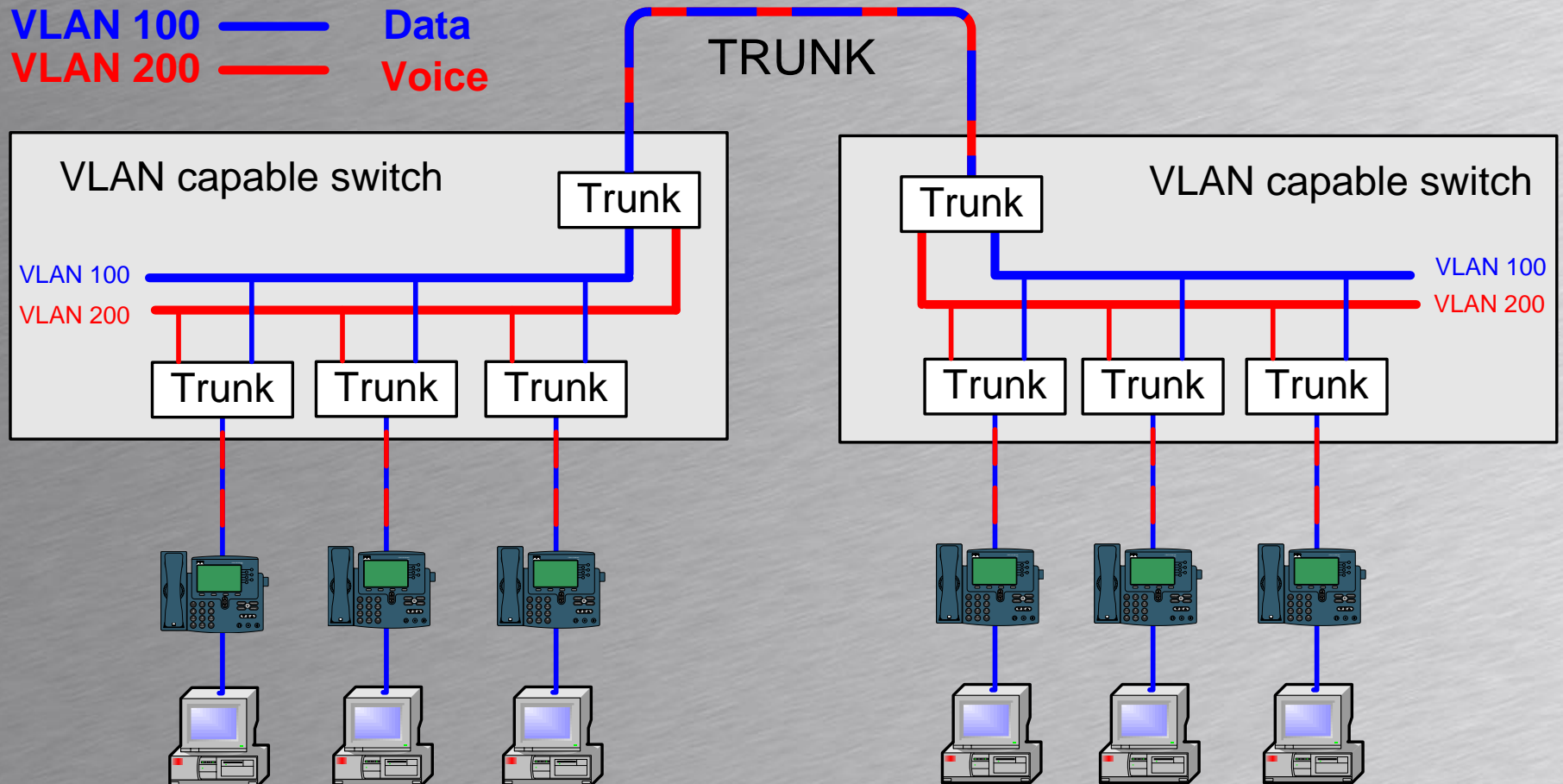



# PoE

## Power over Ethernet

- Most IP phones are powered by 48 Vdc
- Many IP phones can get power from
  - External power supply connected to mains
  - From switches capable of delivering power
    - PoE or Power over Ethernet
    - Picture below is a partial printout from a PoE capable switch

```
mars.tekkom.dk - PuTTY
Campus1#show power inline
Available:280.0 (w)  Used:44.1 (w)  Remaining:235.9 (w)

Interface Admin  Oper      Power   Device          Class Max
          (Watts)
-----
Fa0/1    auto   on        6.3     IP Pnone 7940      2    15.4
Fa0/2    auto   on        6.3     IP Pnone 7940      2    15.4
Fa0/3    auto   off       0.0     -          -         -    15.4
```