



Cisco Networking Academy
Mind Wide Open

Chapter 1: Explore the Network

Introduction to Networks v5.1



Chapter Outline

- 1.0 Introduction
- 1.1 Globally Connected
- 1.2 LANs, WANs, and the Internet
- 1.3 The Network as a Platform
- 1.4 The Changing Network Environment
- 1.5 Summary

Section 1.1: Globally Connected

Upon completion of this section, you should be able to:

- Explain how networks affect the way we interact, learn, work, and play.
- Explain how host devices can be used as clients, servers, or both.

Topic 1.1.1: Networking Today



Networks in Our Daily Lives



Technology Then and Now



No Boundaries

Networks support the way we:

- Learn
- Communicate
- Work
- Play



Topic 1.1.2: Providing Resources in a Network



Networks of Many Sizes



Small Home Networks



Small Office/Home Office Networks



Medium to Large Networks



World Wide Networks

Clients and Servers

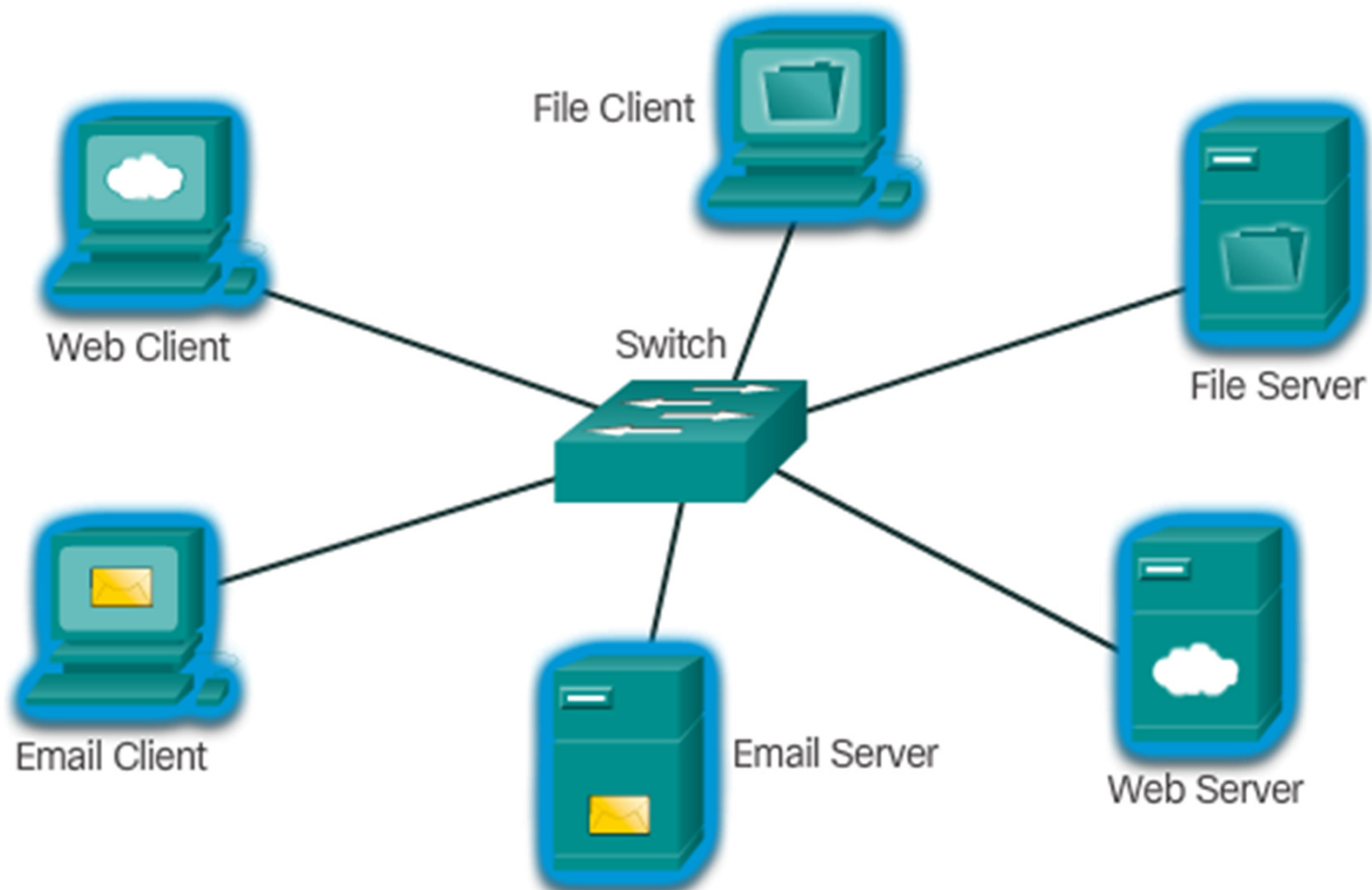

Peer-to-Peer



The advantages of peer-to-peer networking:

- Easy to set up
- Less complexity
- Lower cost since network devices and dedicated servers may not be required
- Can be used for simple tasks such as transferring files and sharing printers

The disadvantages of peer-to-peer networking:

- No centralized administration
- Not as secure
- Not scalable
- All devices may act as both clients and servers which can slow their performance

Section 1.2: LANs, WANs, and the Internet

Upon completion of this section, you should be able to:

- Explain the use of network devices.
- Compare the devices and topologies of a LAN to the devices and topologies of a WAN.
- Describe the basic structure of the Internet.
- Explain how LANs and WANs interconnect to the Internet.

Topic 1.2.1: Network Components



Overview of Network Components

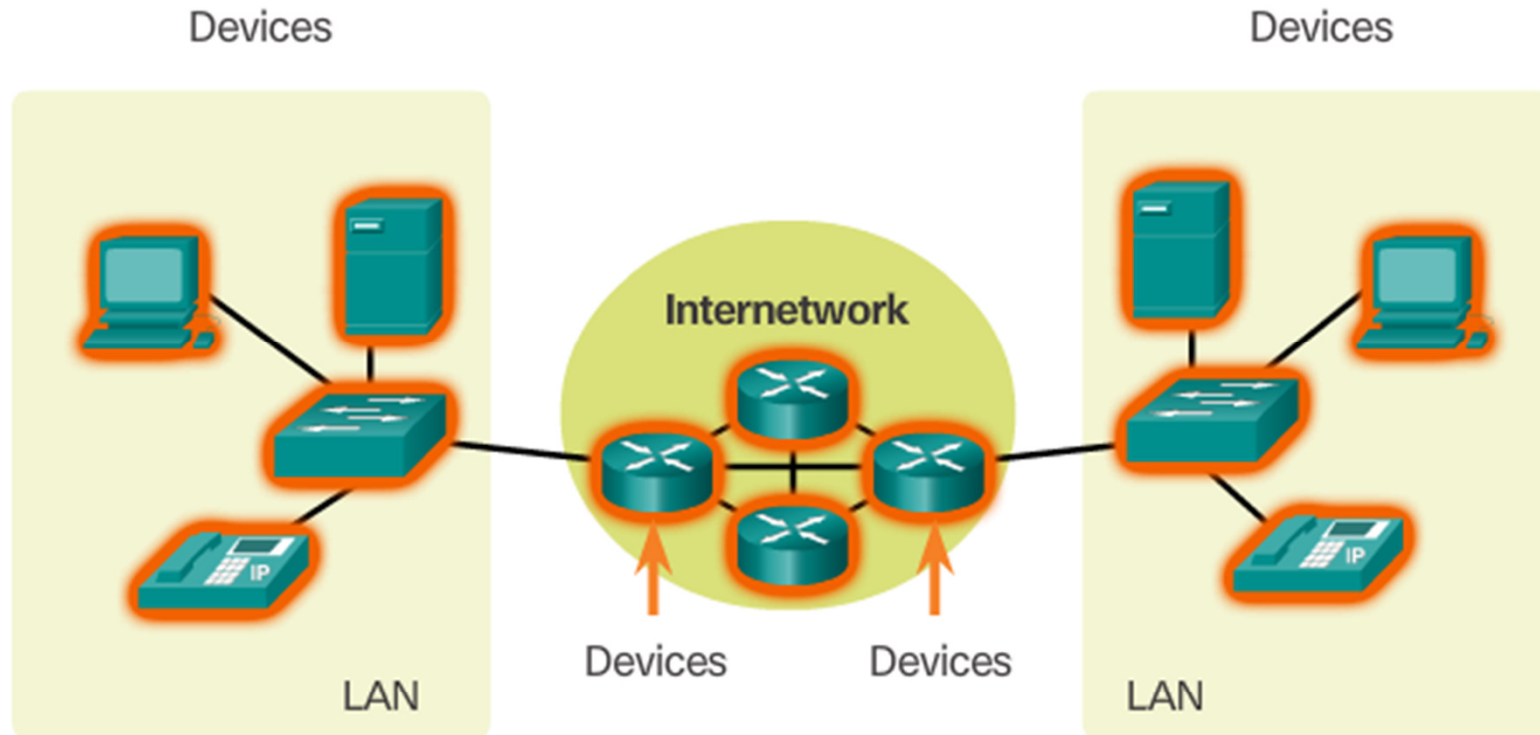

Devices

Media

Services

Overview of Network Components (cont.)

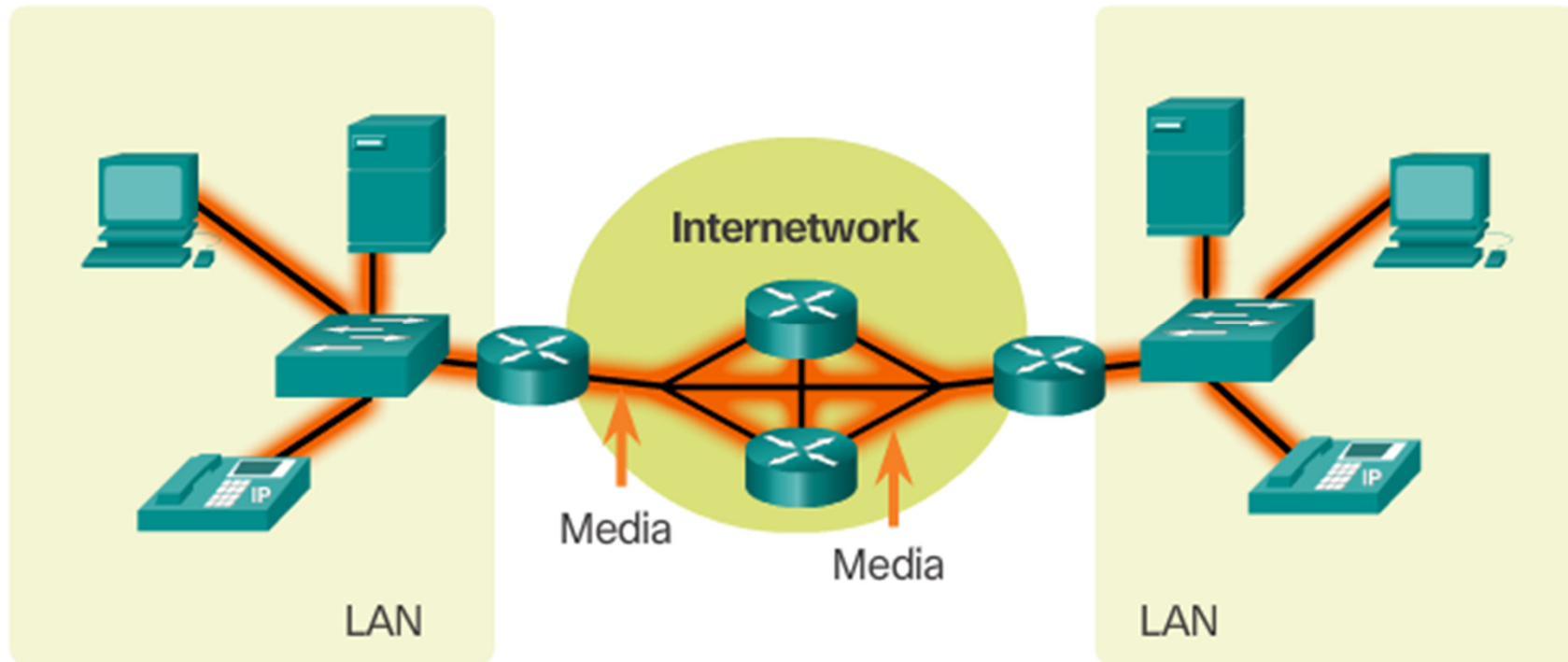

Devices

Media

Services

Overview of Network Components (cont.)

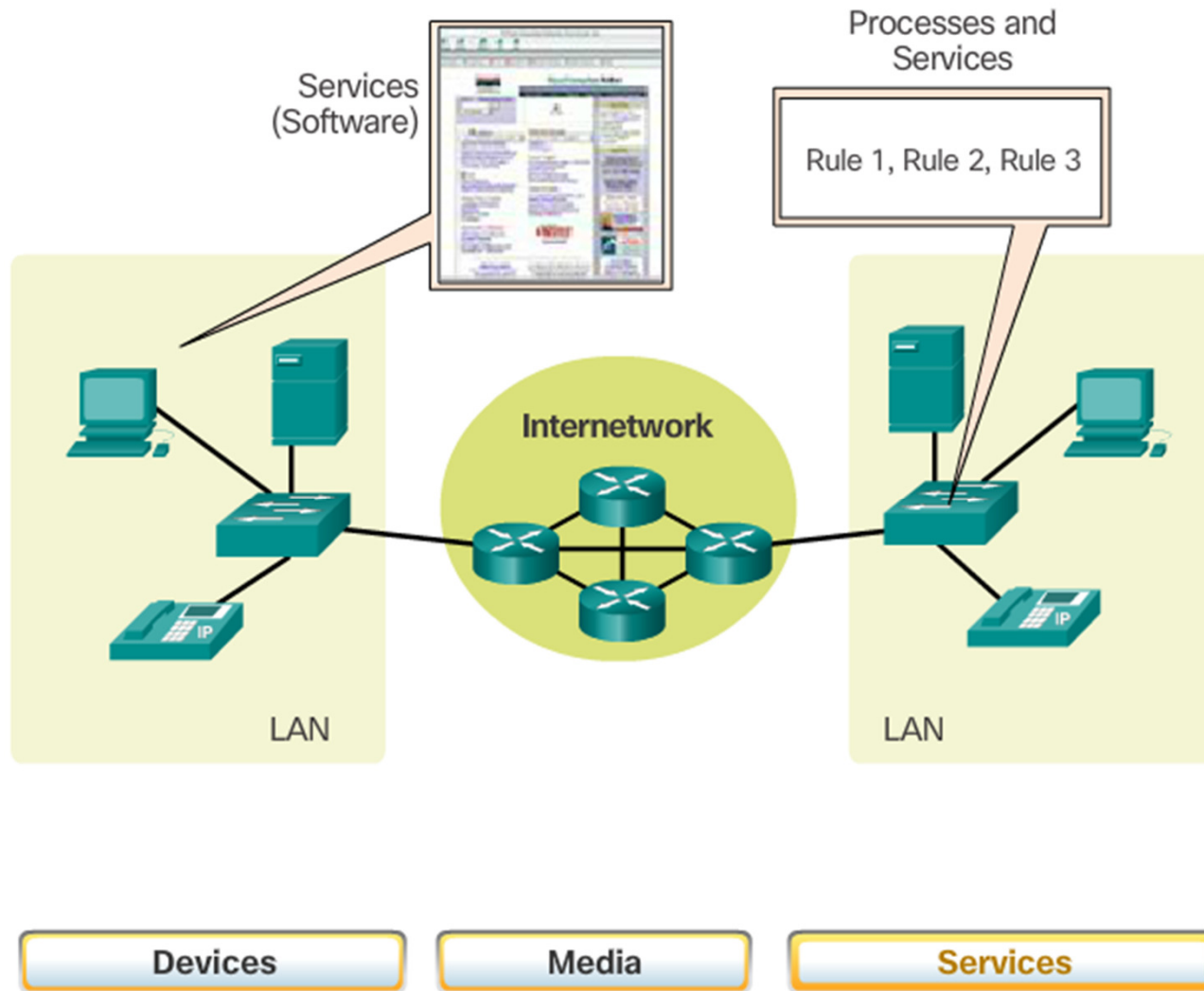

End Devices



Intermediary Network Devices

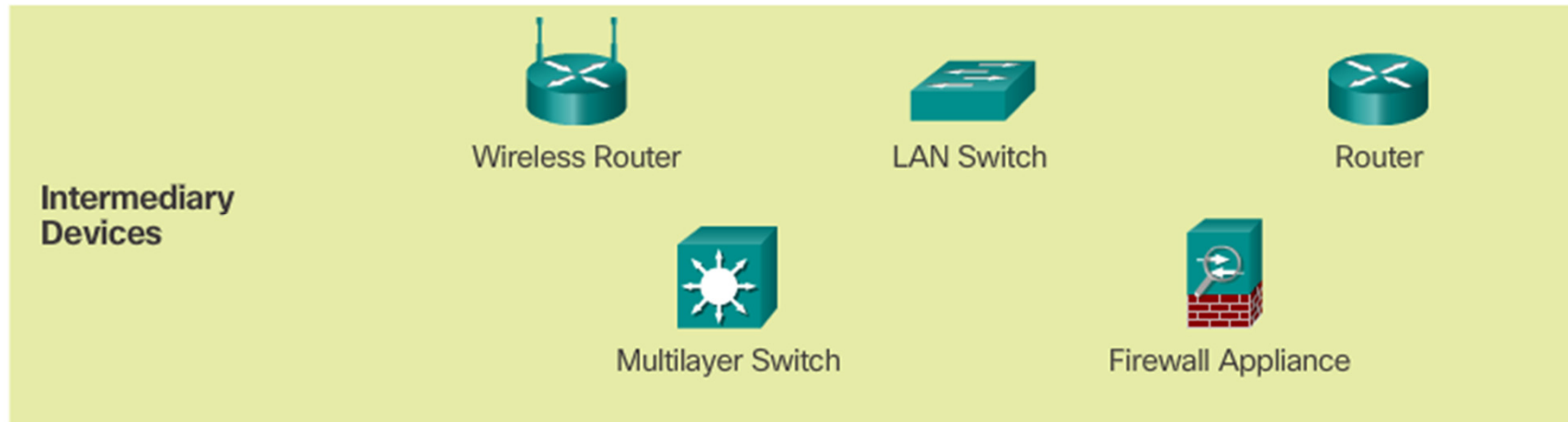

Intermediary network devices perform some or all of these functions:

- Regenerate and retransmit data signals
- Maintain information about what pathways exist through the network and internetwork
- Notify other devices of errors and communication failures
- Direct data along alternate pathways when there is a link failure
- Classify and direct messages according to priorities
- Permit or deny the flow of data, based on security settings

Network Media

Copper

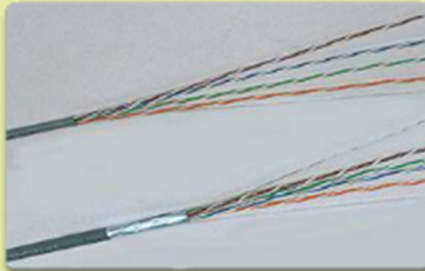

Fiber Optic



Wireless



Network Media (cont.)

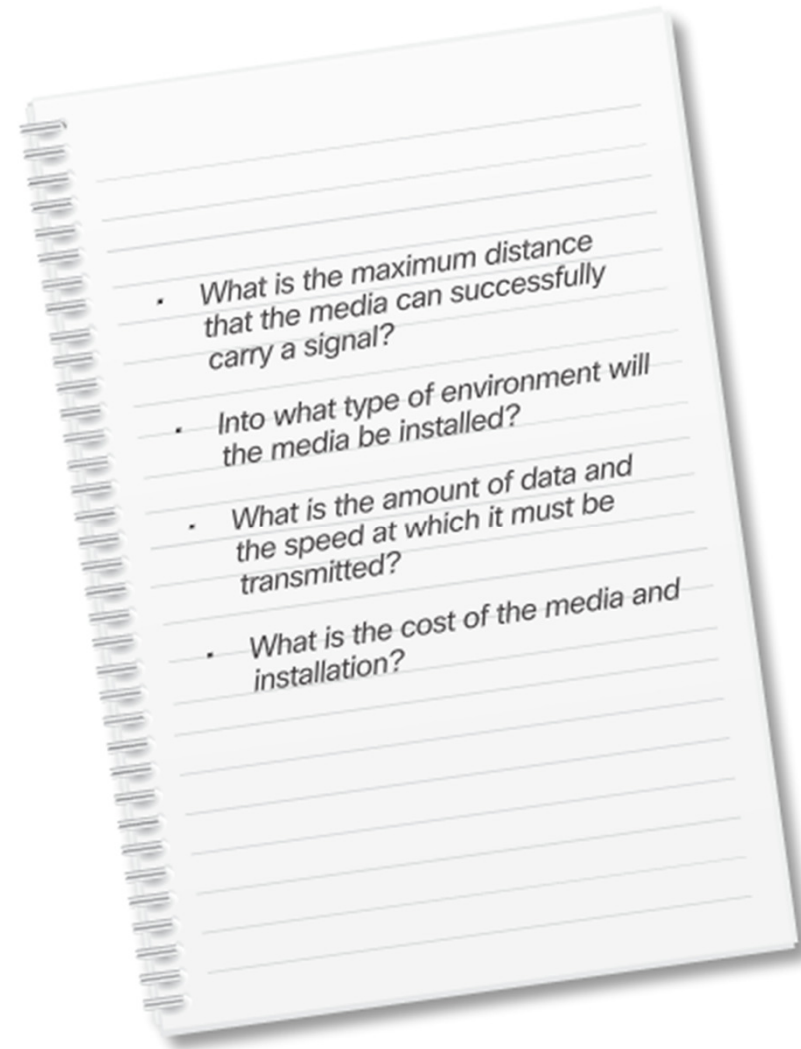

- What is the maximum distance that the media can successfully carry a signal?
- Into what type of environment will the media be installed?
- What is the amount of data and the speed at which it must be transmitted?
- What is the cost of the media and installation?

Network Representations

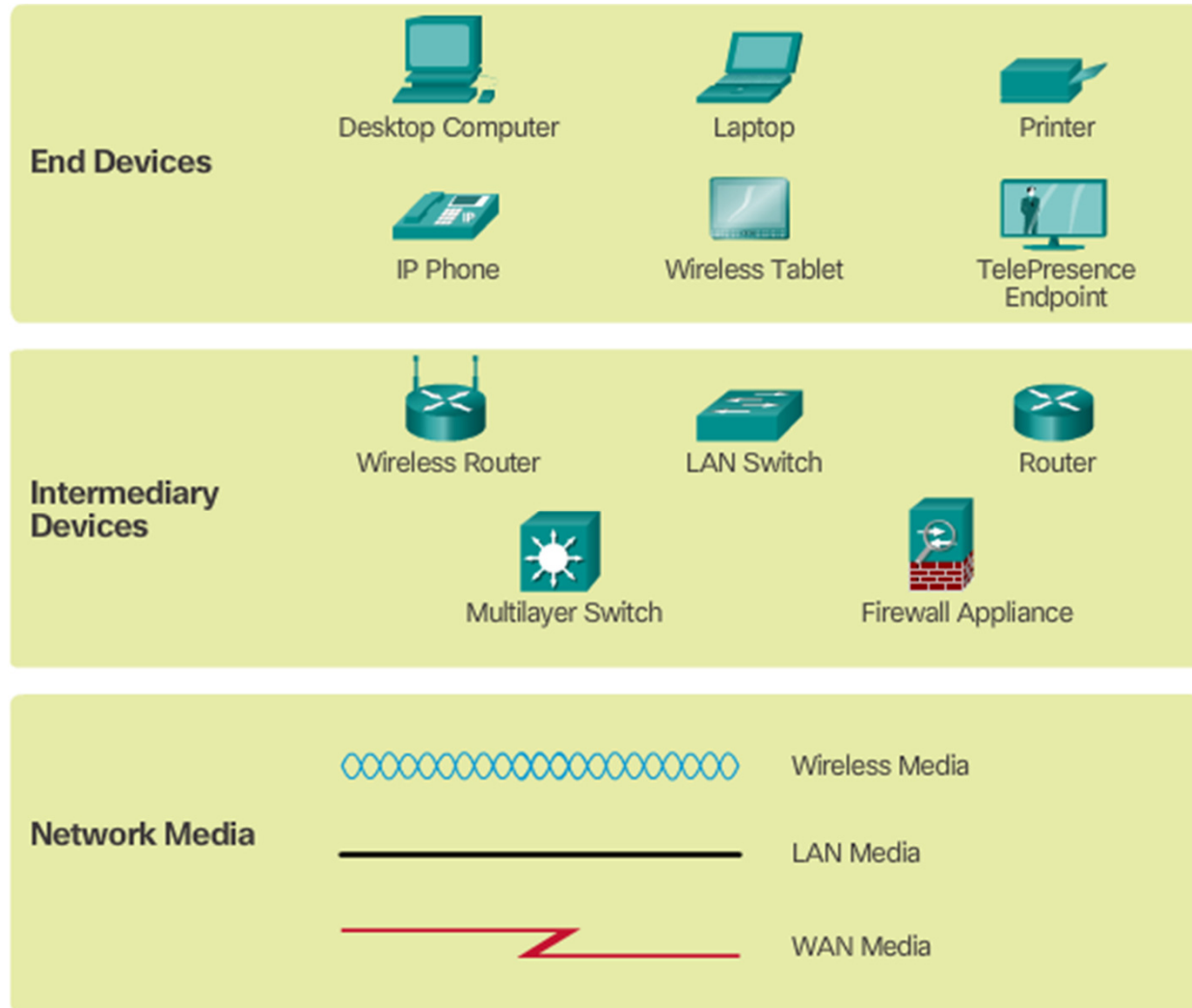

Network Representations (Cont.)

Network Interface Card



Topology Diagrams

Physical Topology

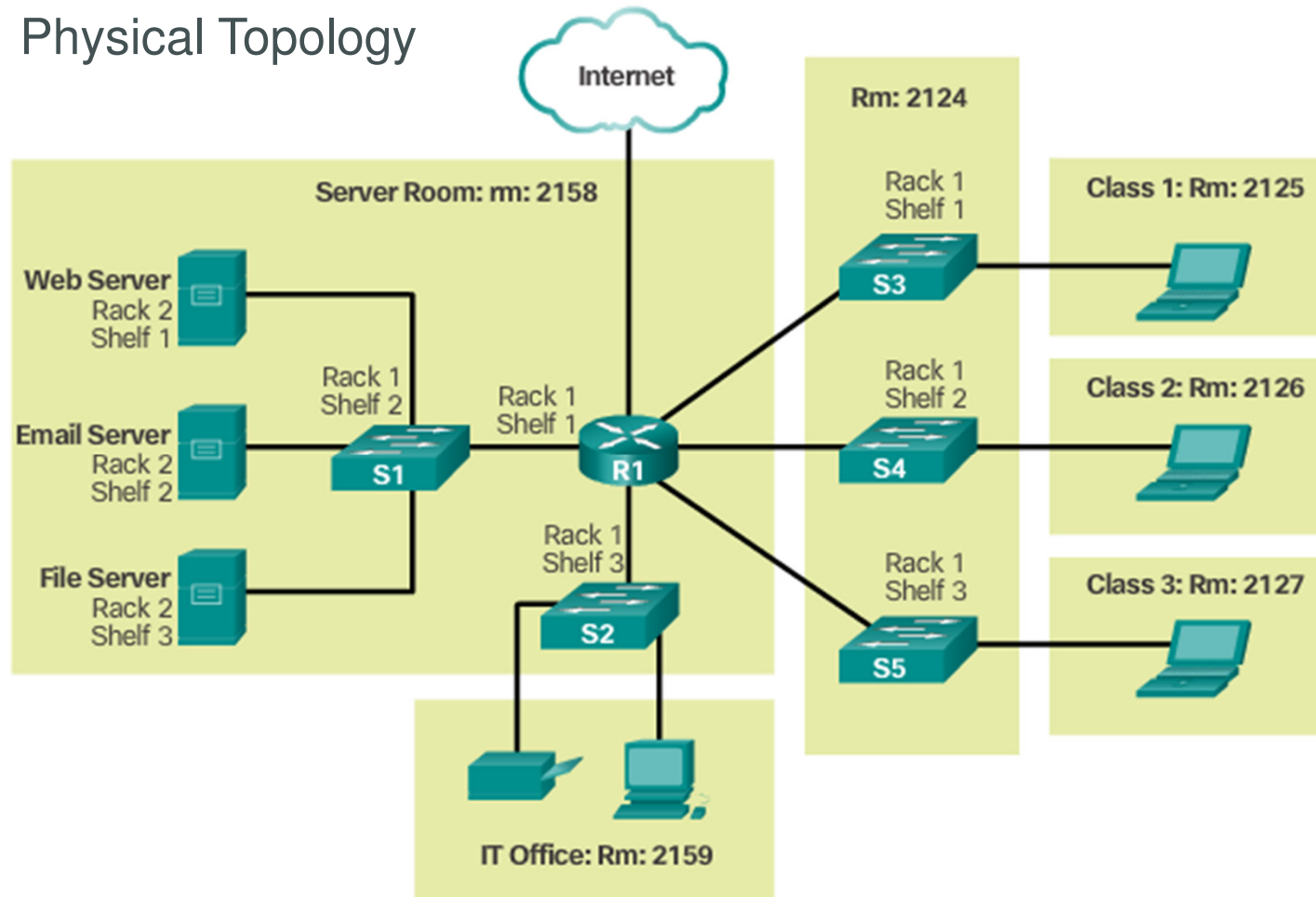

Topology Diagrams (Cont.)

Logical Topology

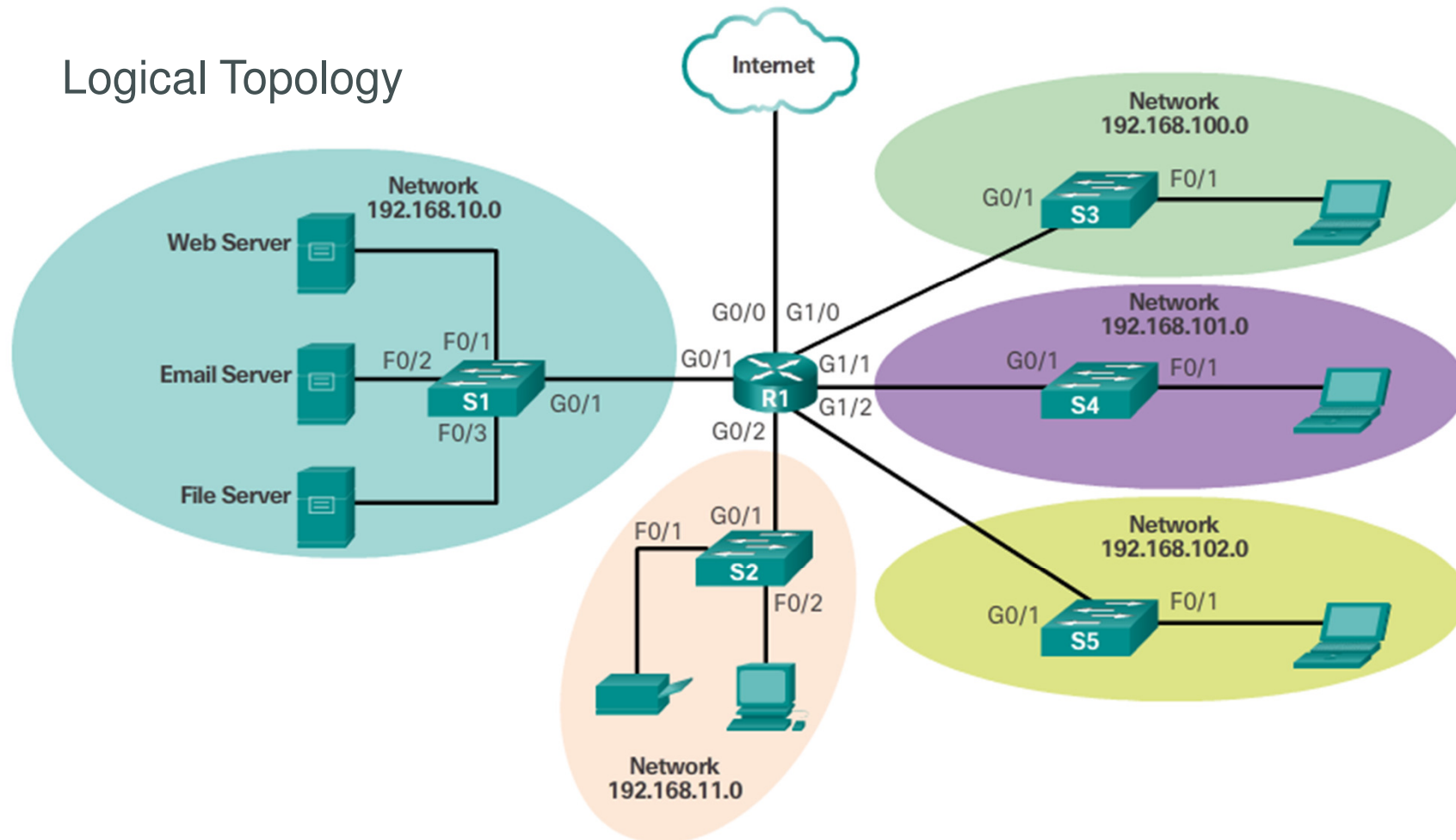

Topic 1.2.2: LANs and WANs



Types of Networks

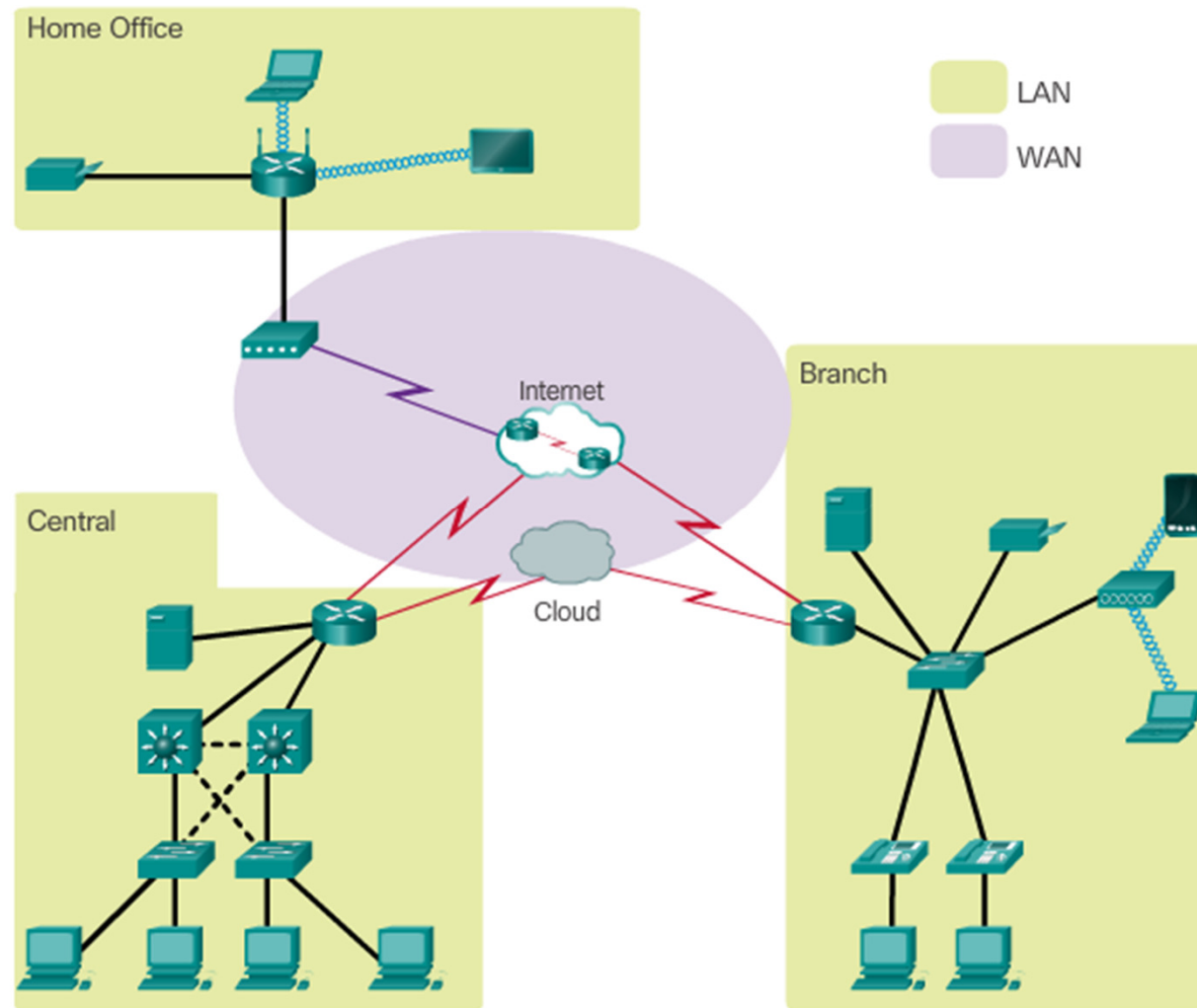

Types of Networks

The two most common types of network infrastructures are:

- Local Area Network (LAN)
- Wide Area Network (WAN)

Other types of networks include:

- Metropolitan Area Network (MAN)
- Wireless LAN (WLAN)
- Storage Area Network (SAN)

Local Area Networks

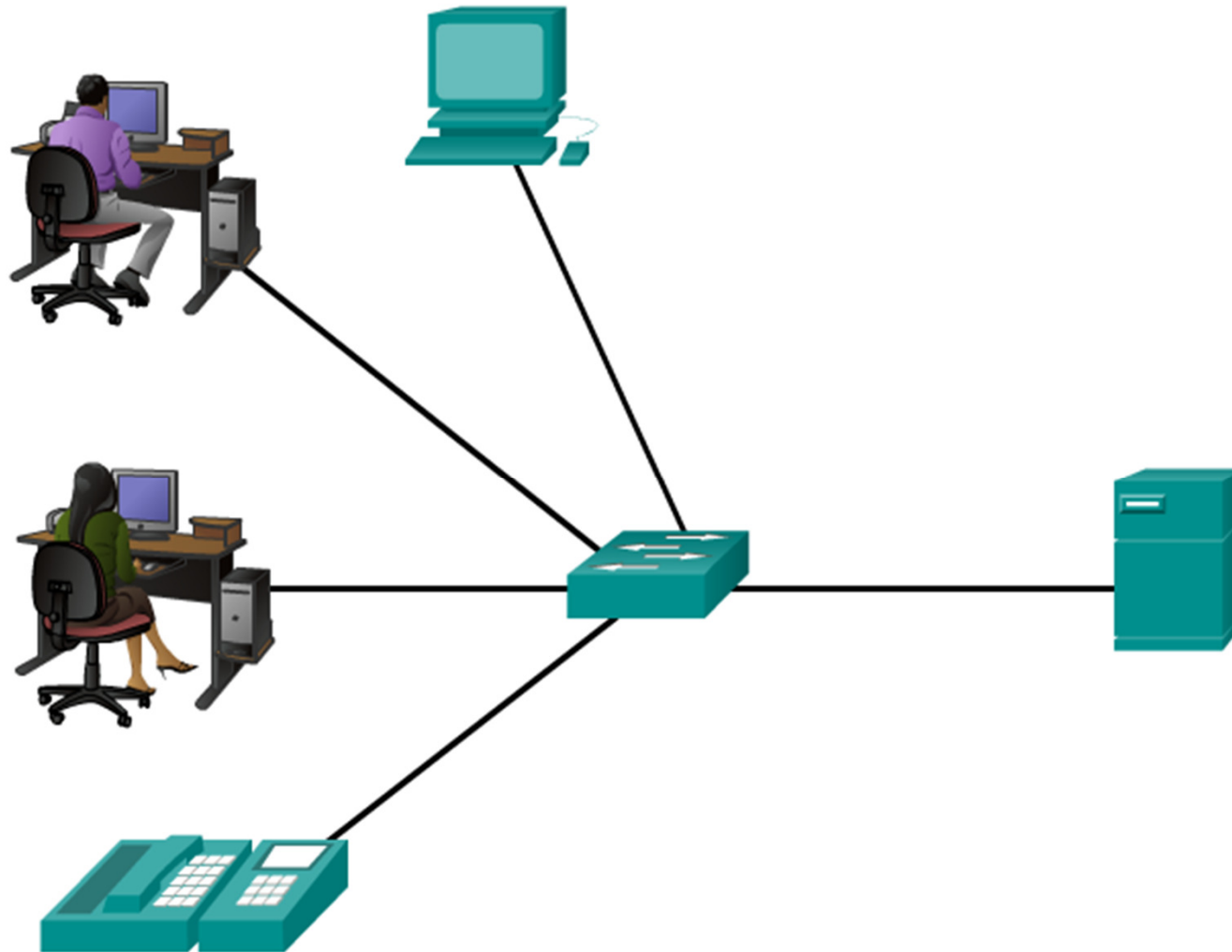

Wide Area Networks

LANs separated by geographic distance are connected by a network known as a WAN.

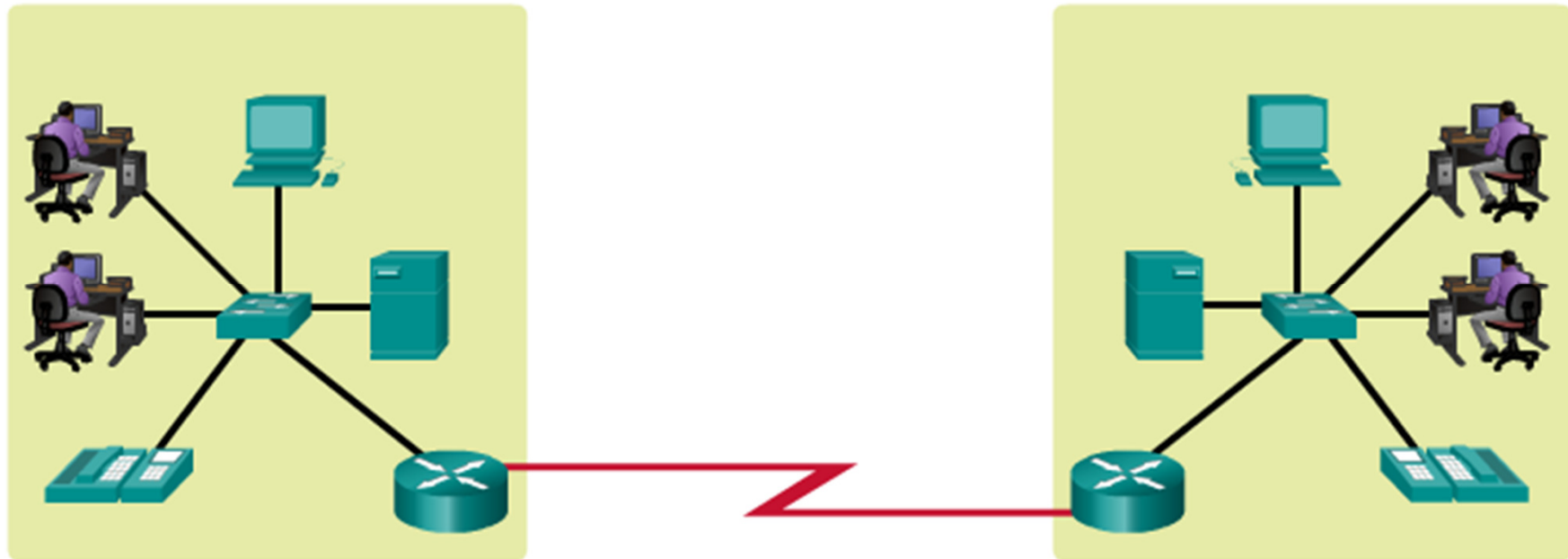

Topic 1.2.3: The Internet, Intranets, and Extranets



The Internet

LANs use WAN services to interconnect.

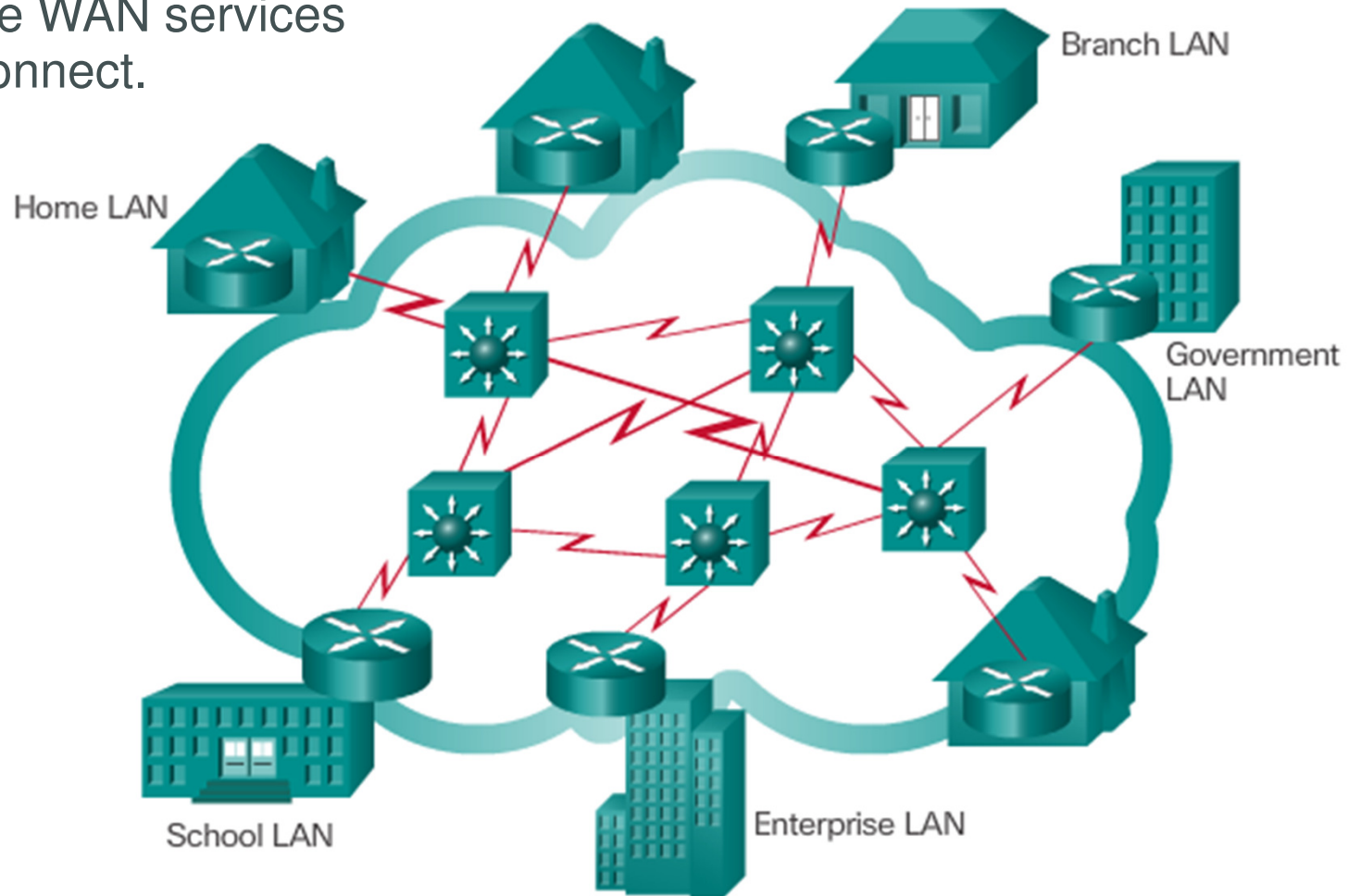

Intranets and Extranets

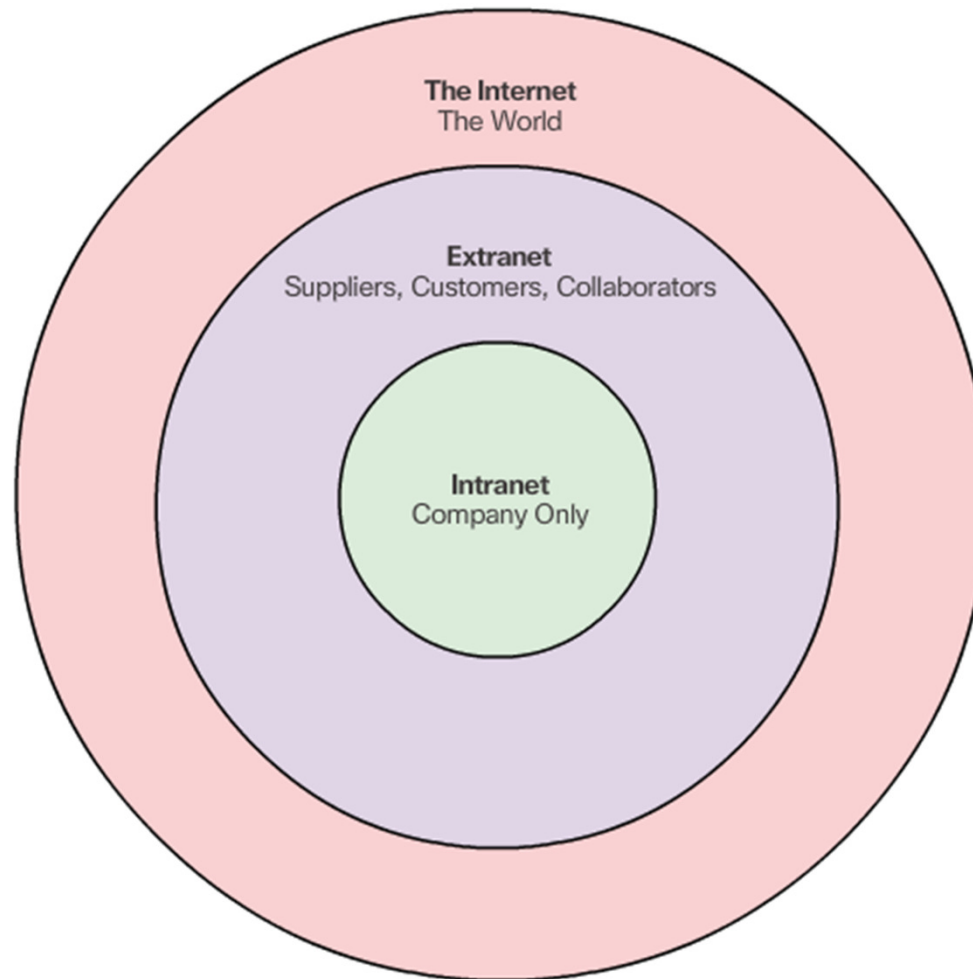

Topic 1.2.4: Internet Connections



Internet Access Technologies

- Internet Service Provider (ISP)
- Broadband cable
- Broadband Digital Subscriber Line (DSL)
- Wireless WANs
- Mobile Services
- Business DSL
- Leased Lines
- Metro Ethernet



Home and Small Office Internet Connections

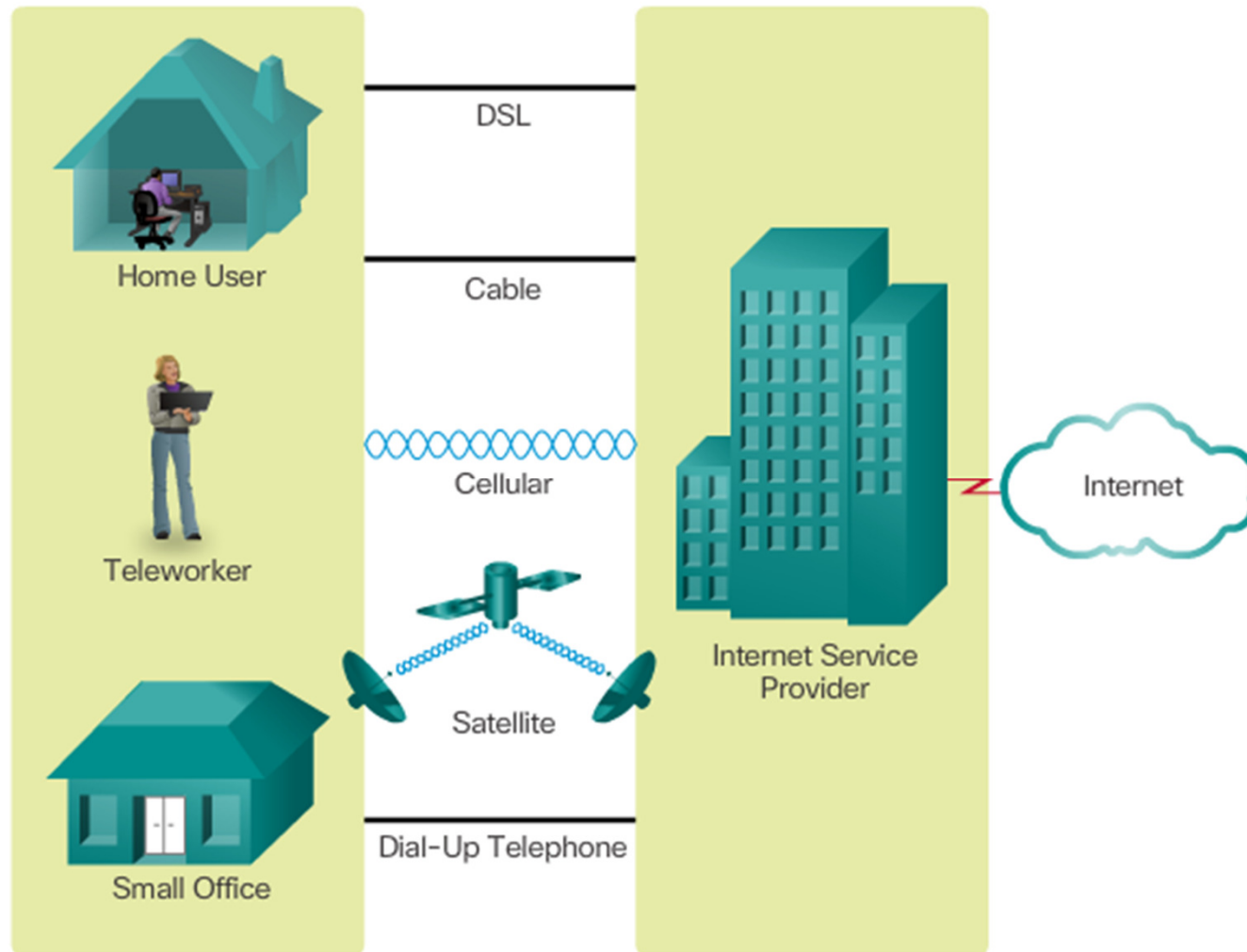

Business Internet Connections

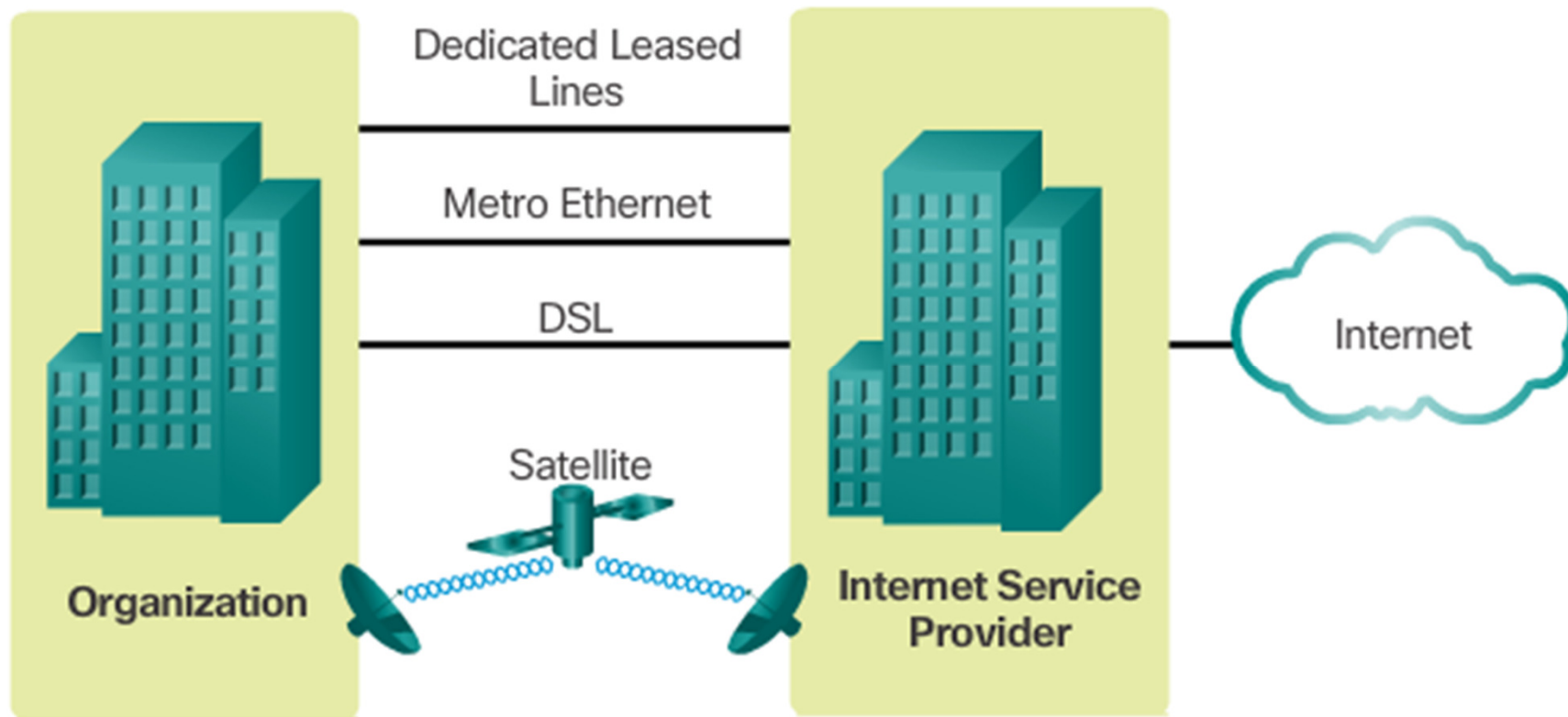

Section 1.3:

The Network as a Platform

Upon completion of this section, you should be able to:

- Explain the concept of a converged network.
- Describe the four basic requirements of a reliable network.

Topic 1.3.1: Converged Networks



Traditional Separate Networks

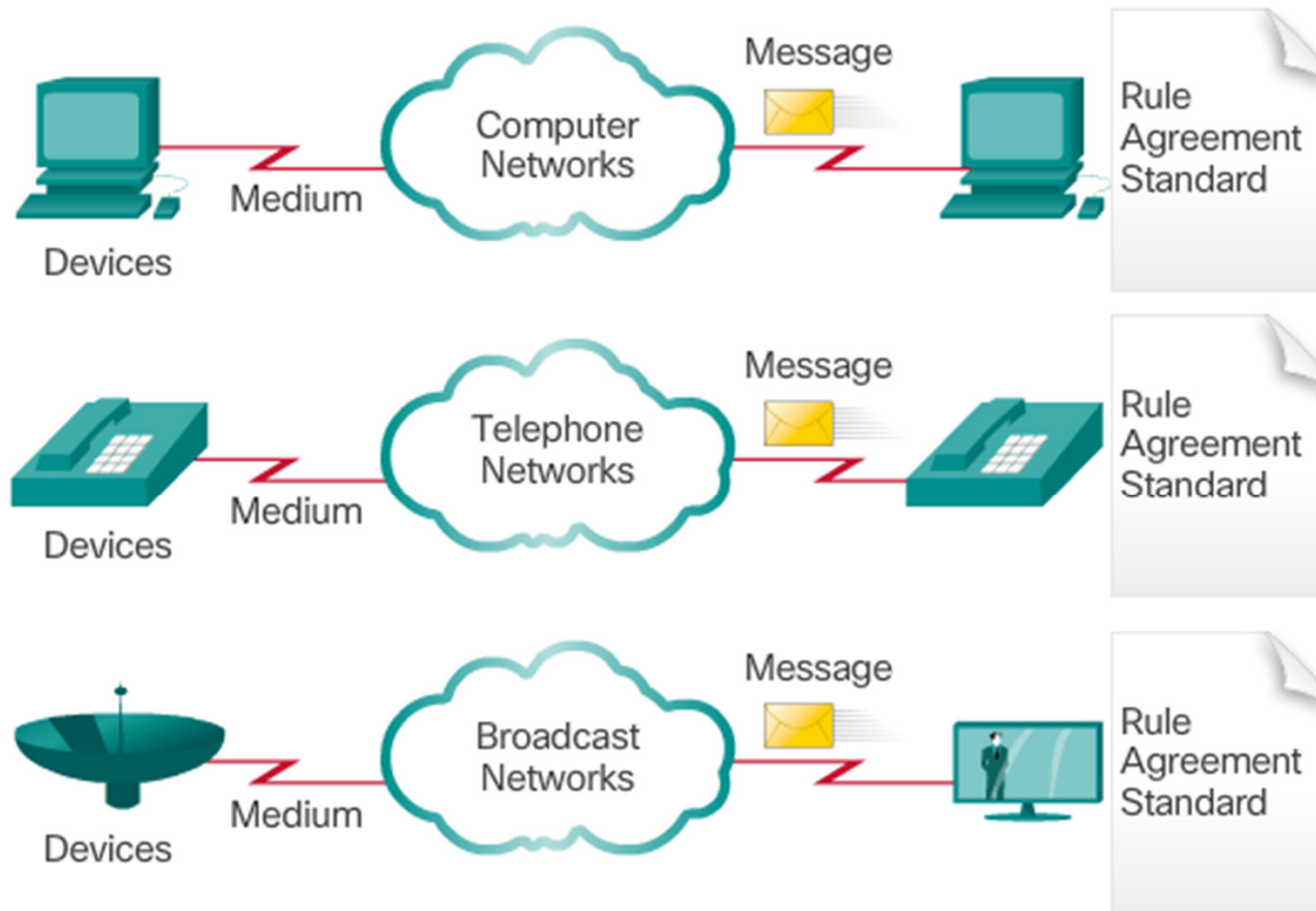

Multiple services are running on multiple networks.

The Converging Networks

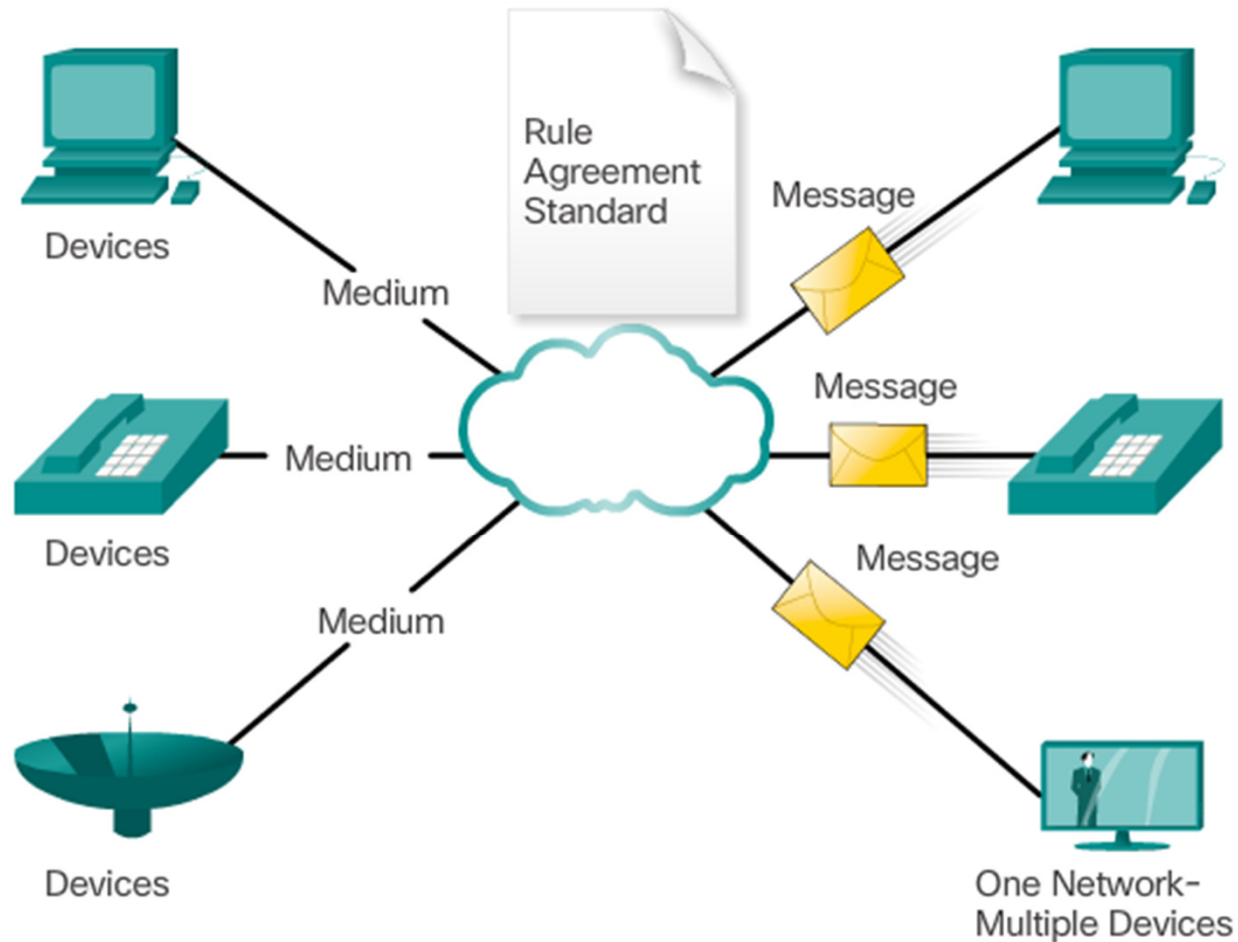

Converged data networks carry multiple services on one network.

Topic 1.3.2: Reliable Networks



Network Architecture

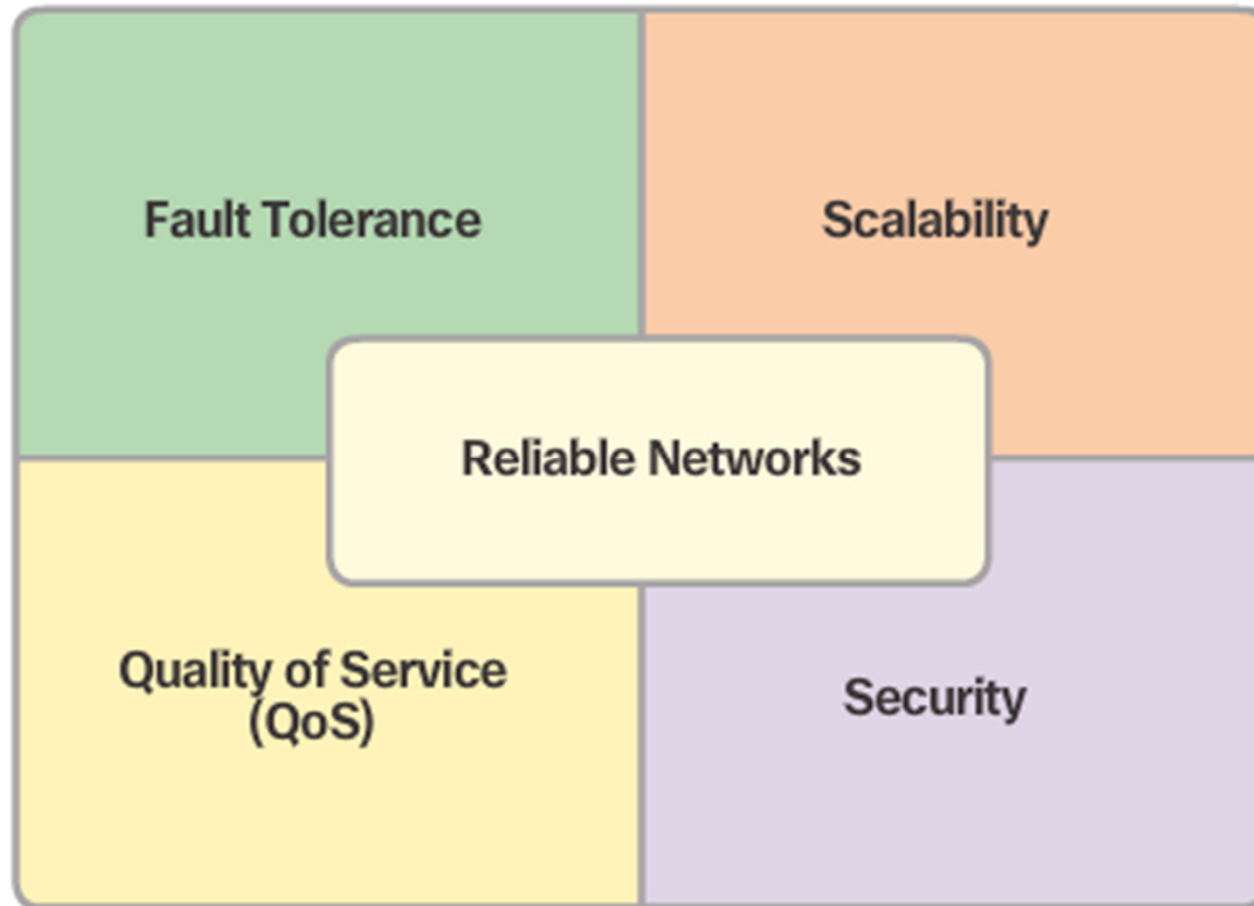

Fault Tolerance

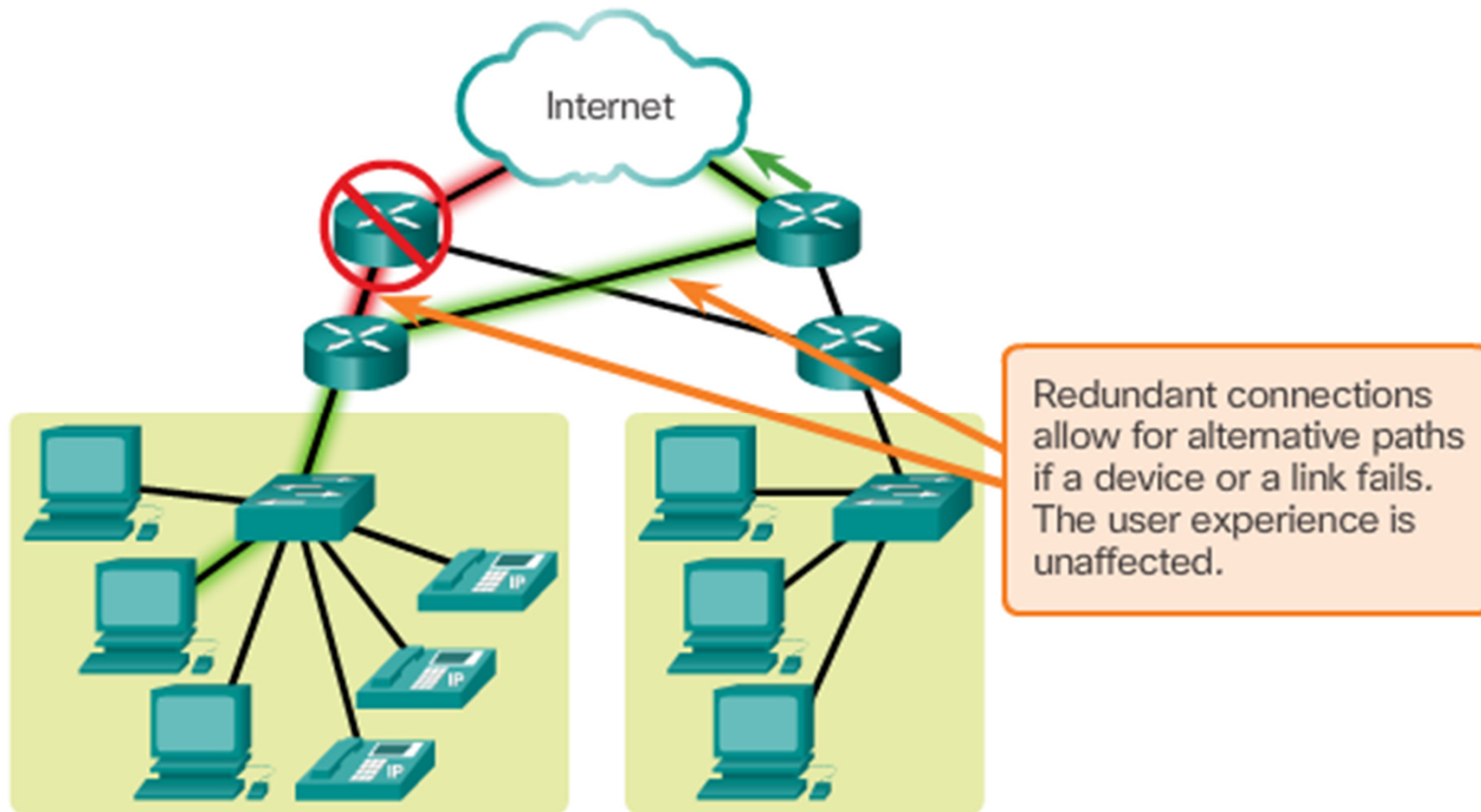

Scalability

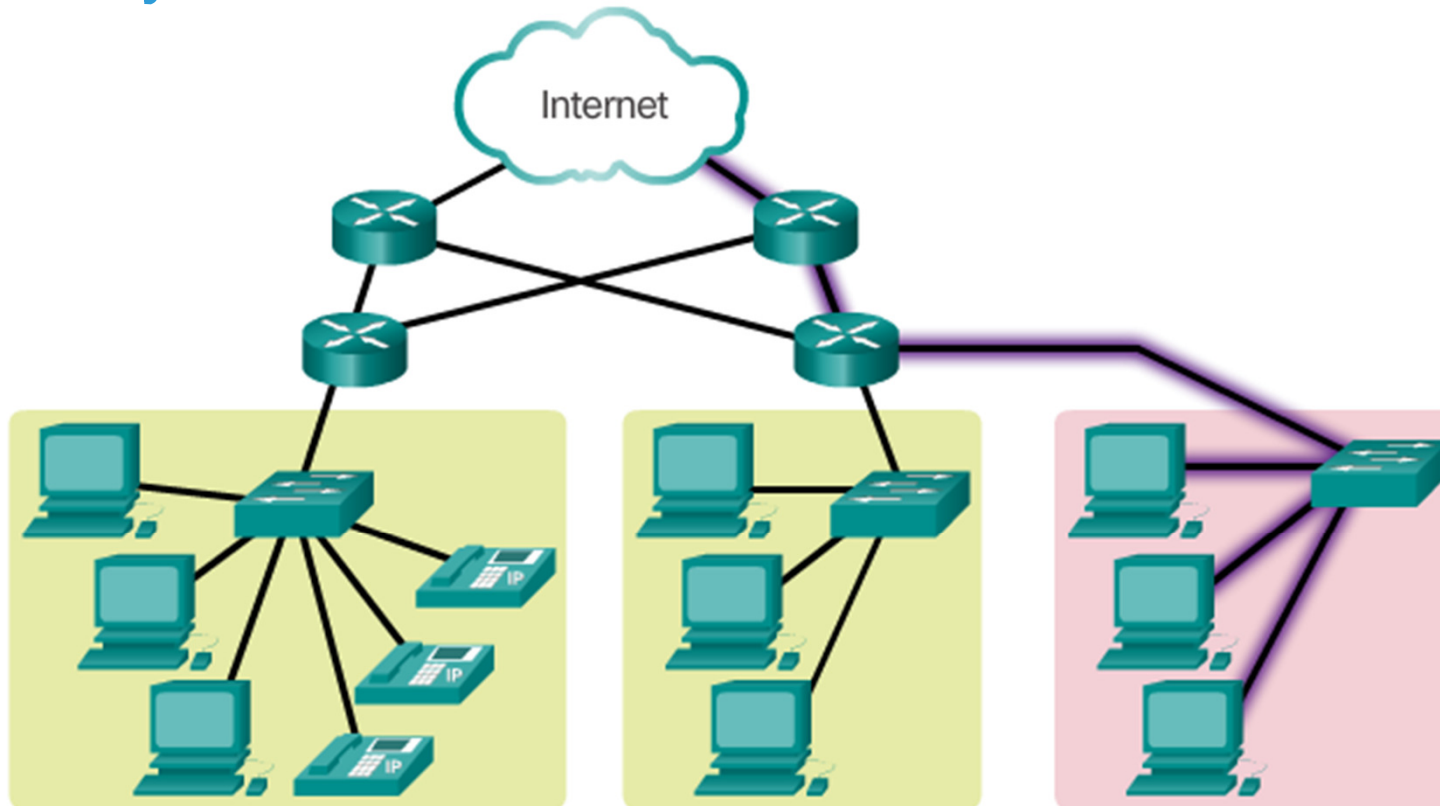

Additional users and whole networks can be connected to the Internet without degrading performance for existing users.

Quality of Service

Quality of Service, managed by the router, ensures that priorities are matched with the type of communication and its importance to the organization.

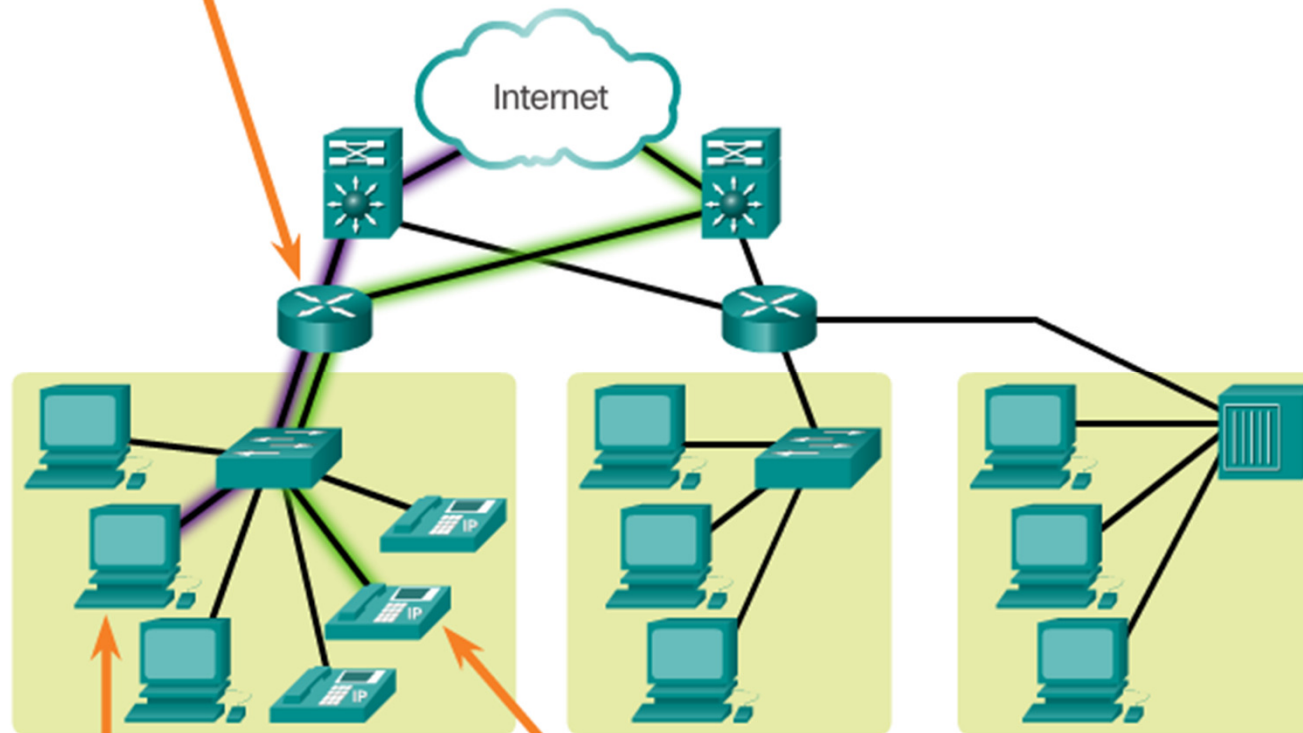

Web pages can usually receive a lower priority.

Streaming media will need priority to maintain a smooth, uninterrupted user experience.

Security

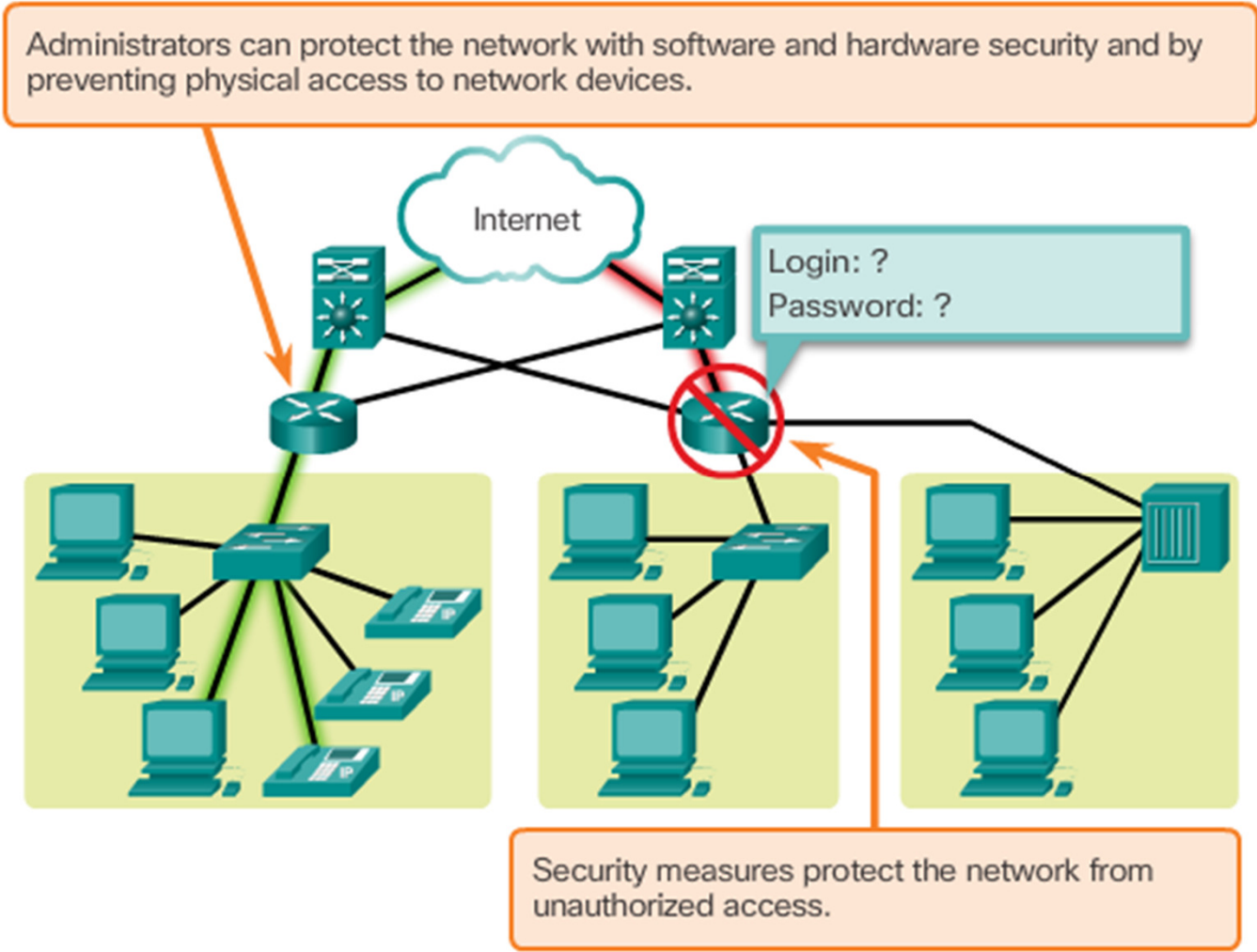

Security (cont.)

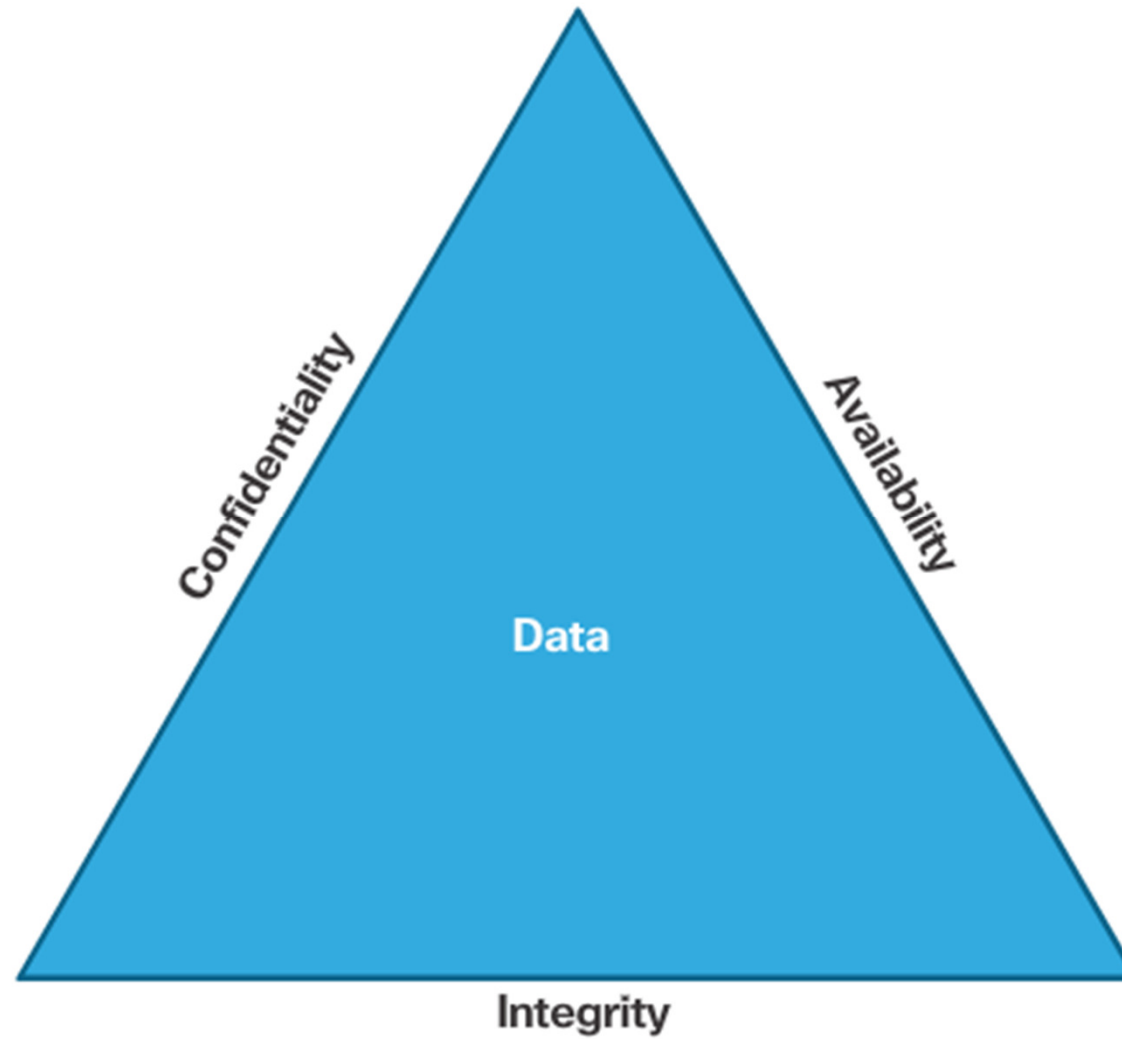

Section 1.4:

The Changing Network Environment

Upon completion of this section, you should be able to:

- Explain how trends such as BYOD, online collaboration, video, and cloud computing are changing the way we interact.
- Explain how networking technologies are changing the home environment.
- Identify basic security threats and solutions for both small and large networks.
- Describe the importance of understanding the underlying switching and routing infrastructure of a network.

Topic 1.4.1: Network Trends



New Trends

Top trends include:

- Bring Your Own Device (BYOD)
- Online collaboration
- Video communications
- Cloud computing



Bring Your Own Device

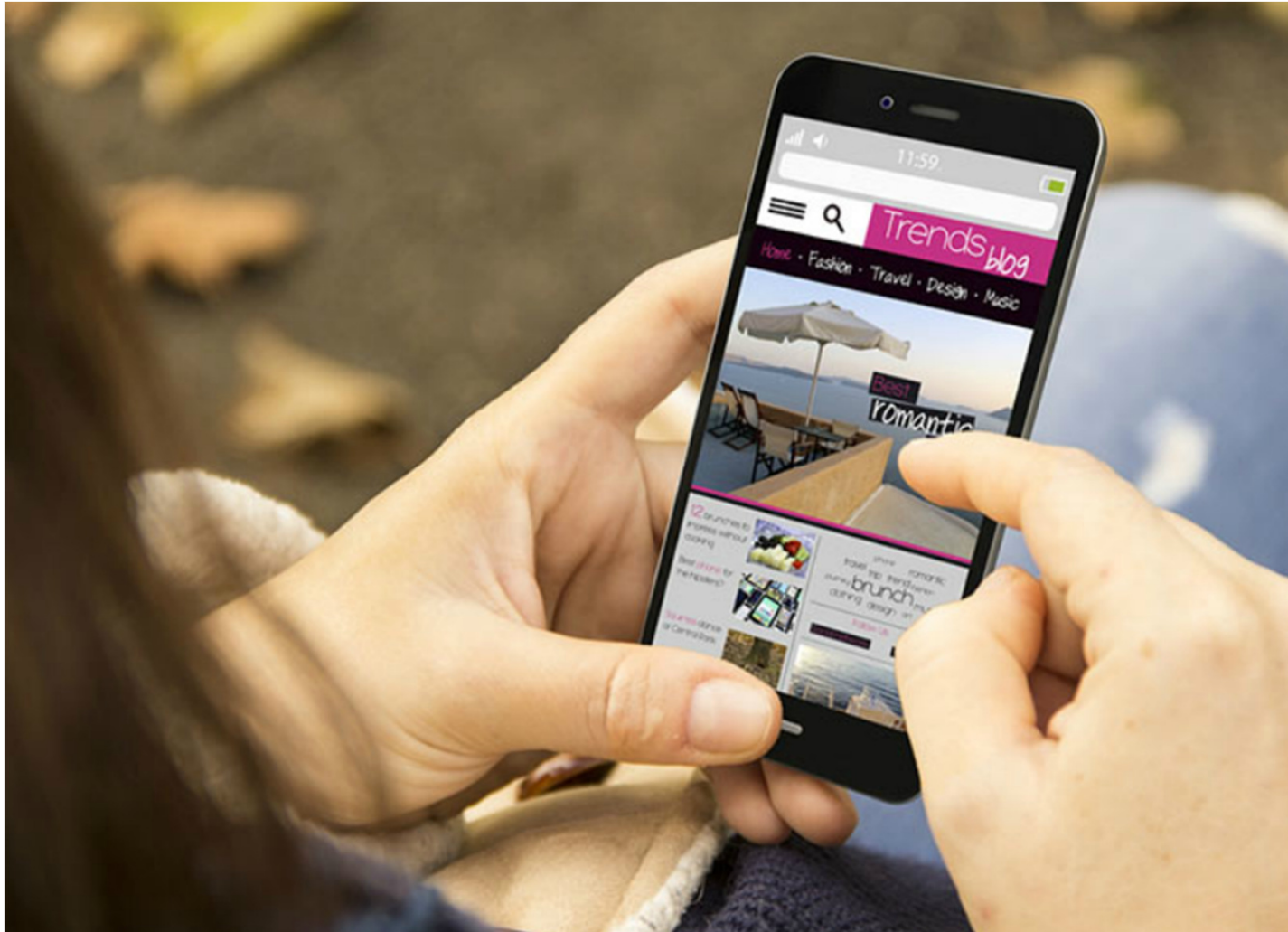

Online Collaboration



Video Communication



Cloud Computing

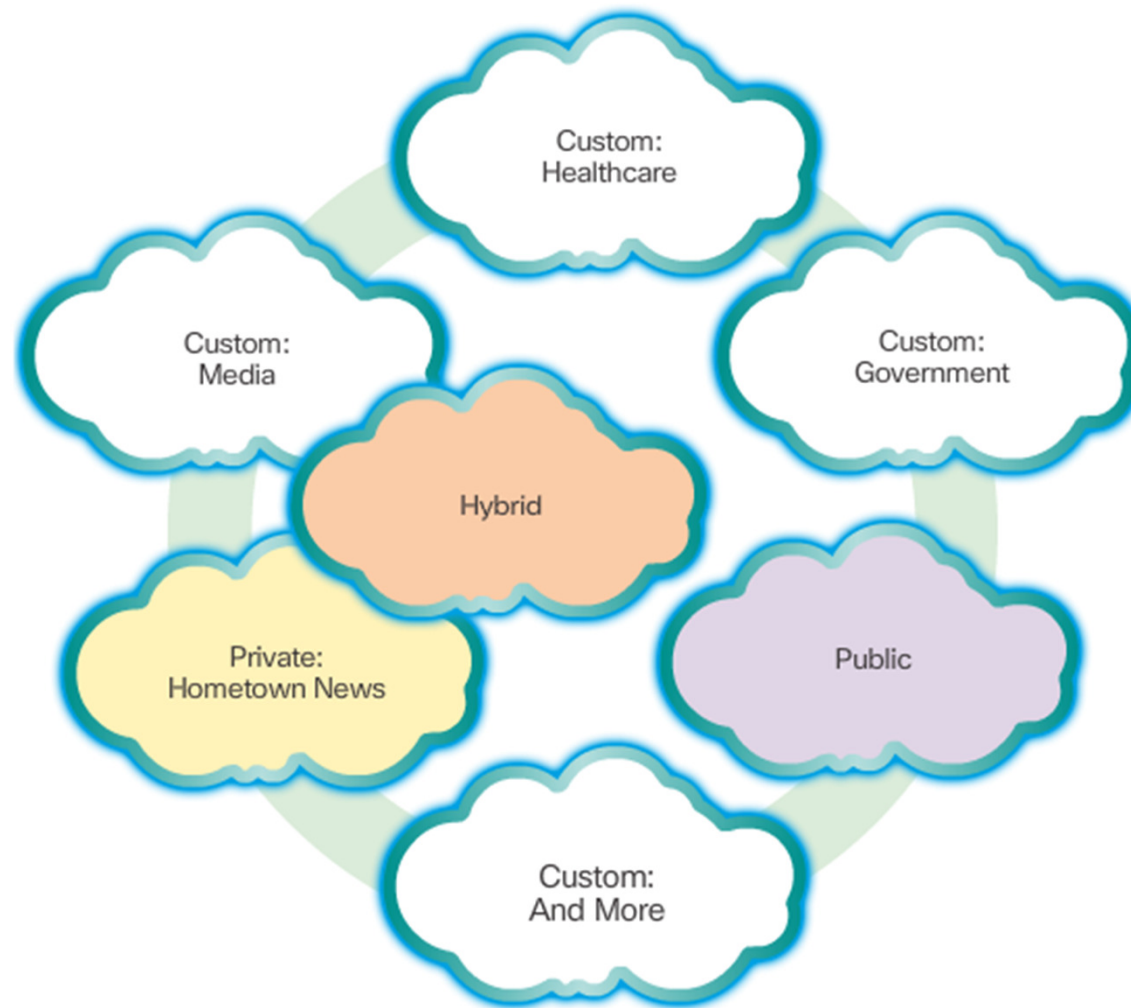

Topic 1.4.2: Networking Technologies for the Home



Technology Trends in the Home

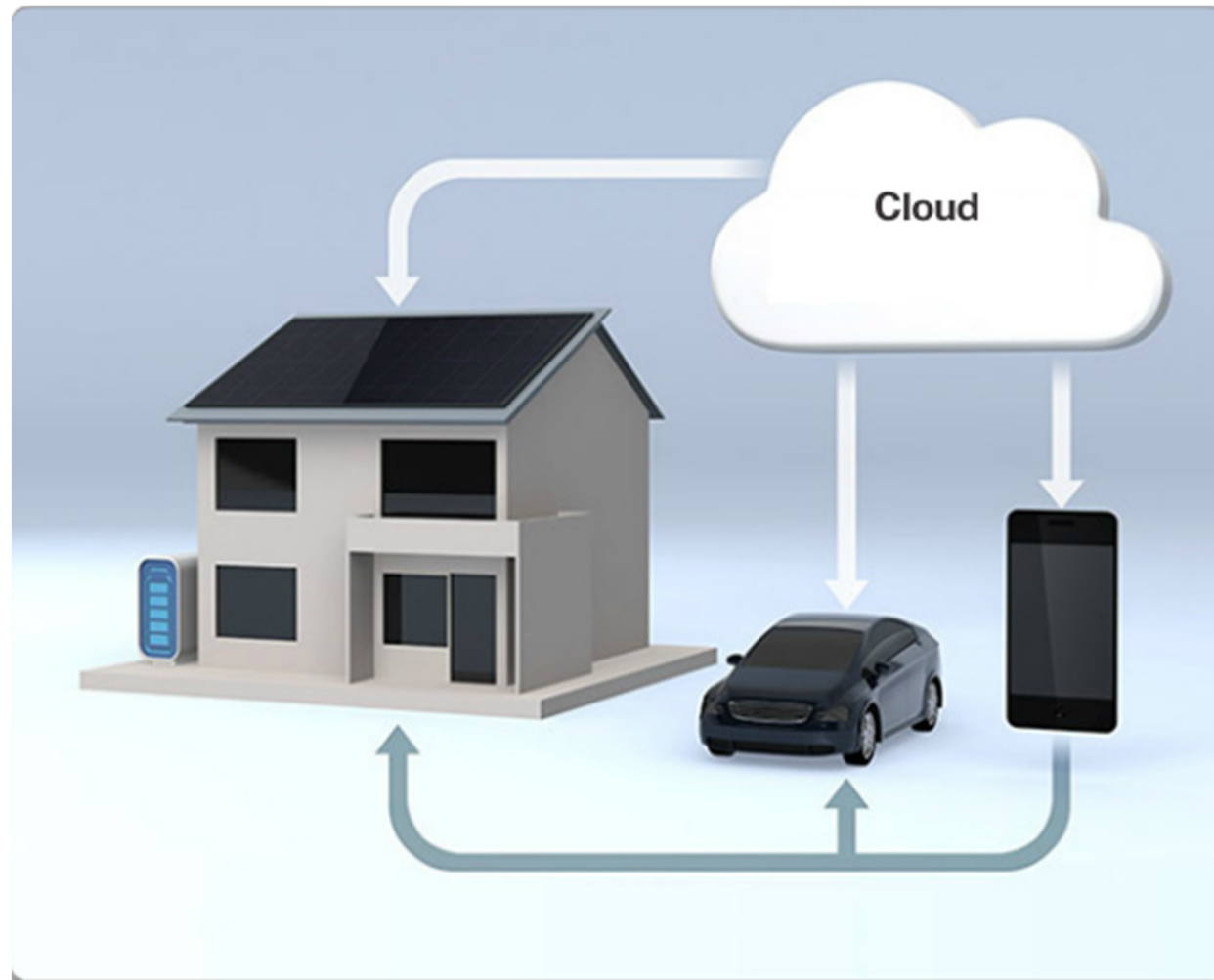

Powerline Networking

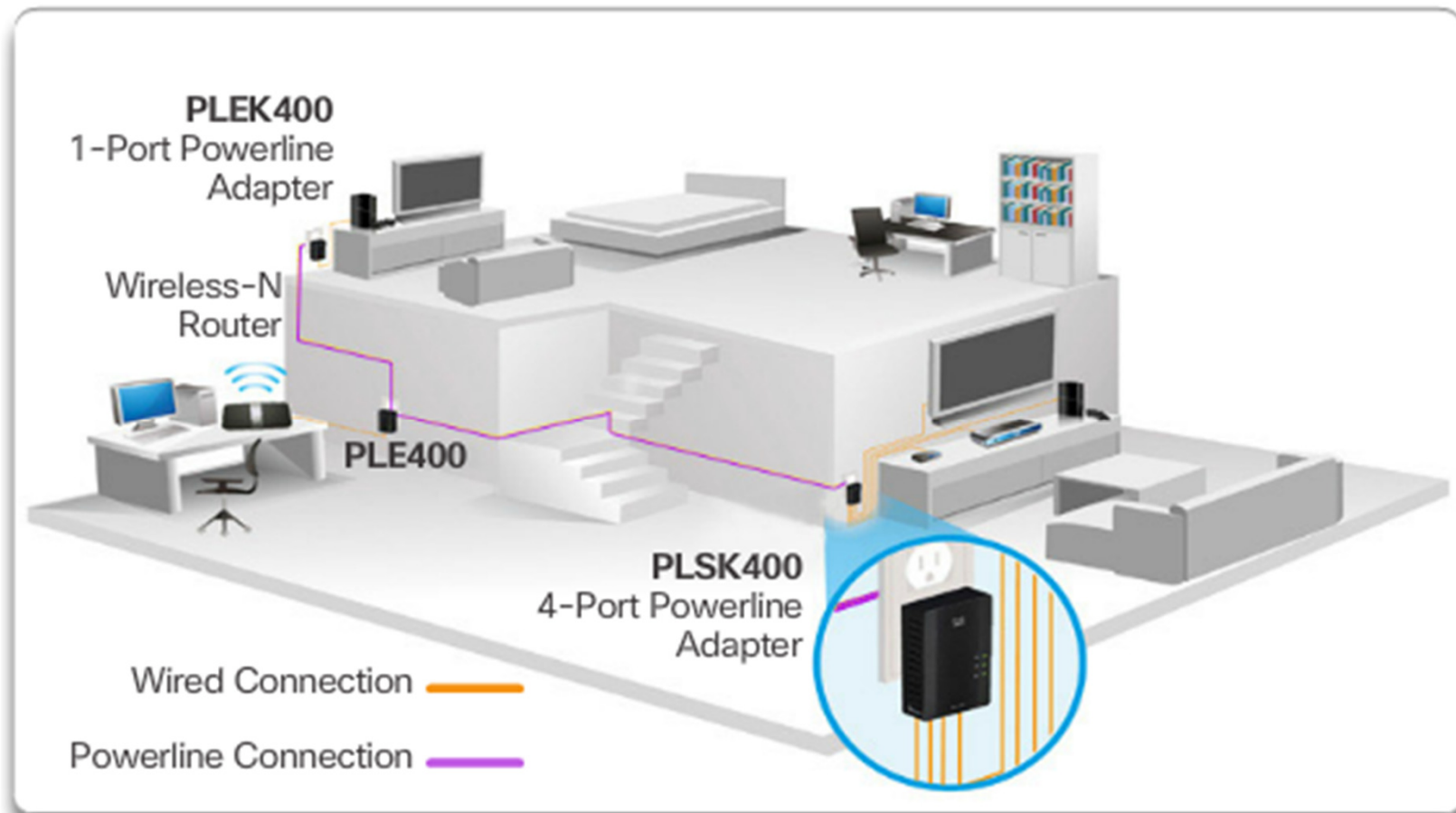

Wireless Broadband



Topic 1.4.3: Network Security



Security Threats

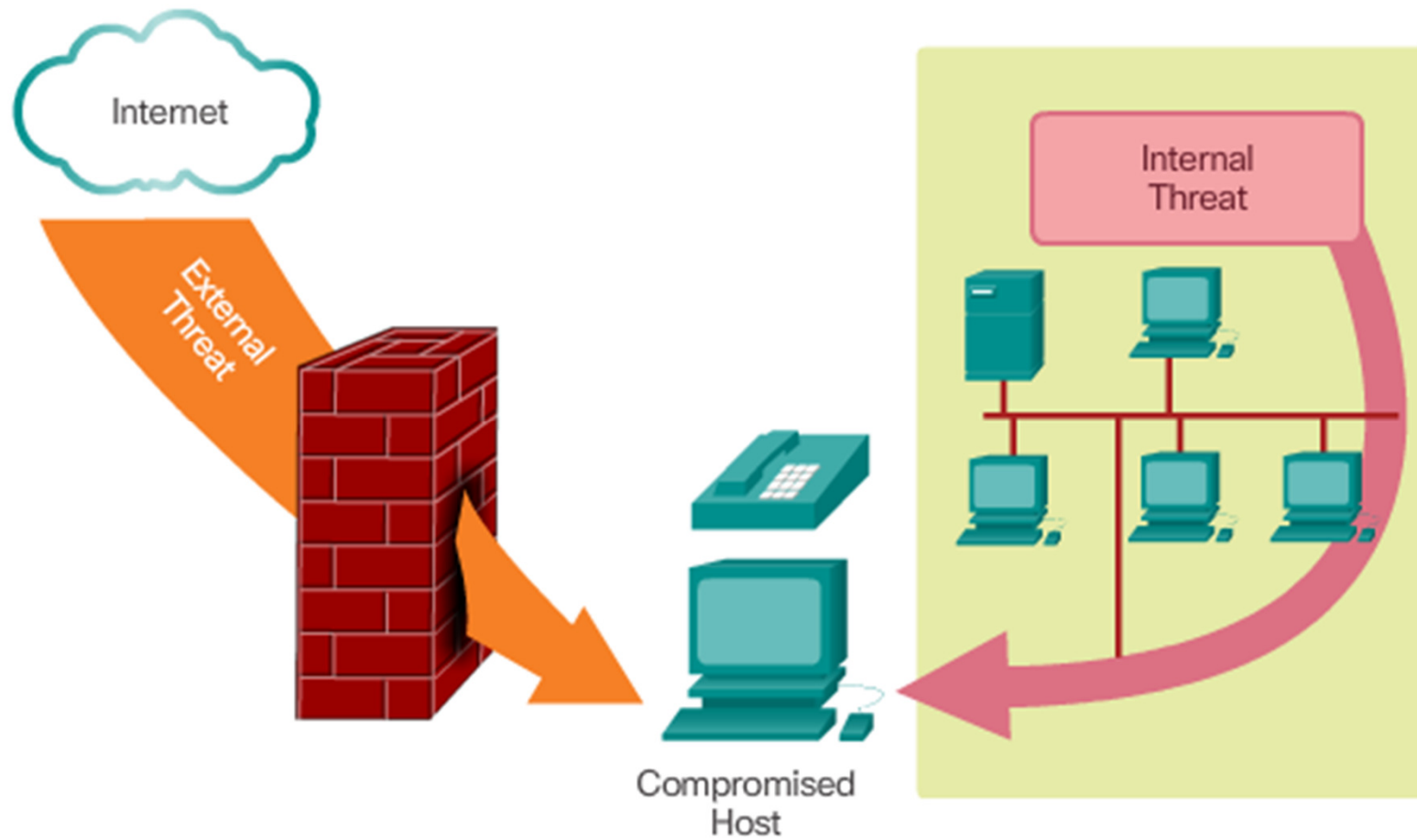

Security Threats

The most common external threats to networks include:

- Viruses, worms, and Trojan horses
- Spyware and adware
- Zero-day attacks, also called zero-hour attacks
- Hacker attacks
- Denial of service attacks
- Data interception and theft
- Identity theft

Security Solutions

Minimum solutions:

- Antivirus and antispysware
- Firewall filtering

Additional solutions:

- Dedicated firewall systems
- Access control lists (ACL)
- Intrusion prevention systems (IPS)
- Virtual Private Networks (VPNs)

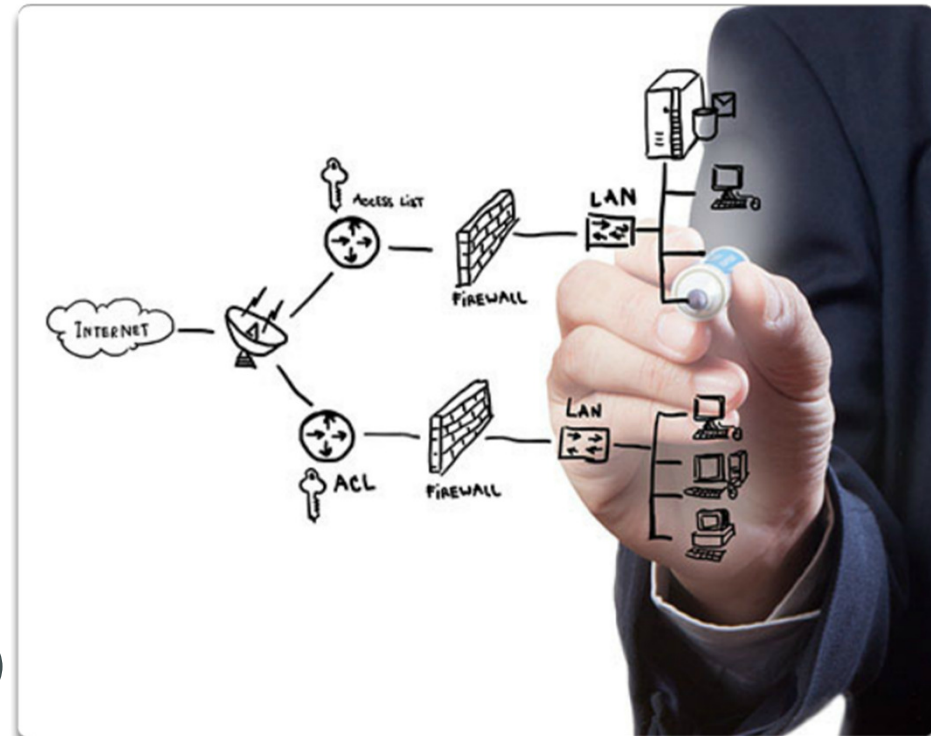

Topic 1.4.4: Network Architecture



Cisco Network Architecture



CCNA

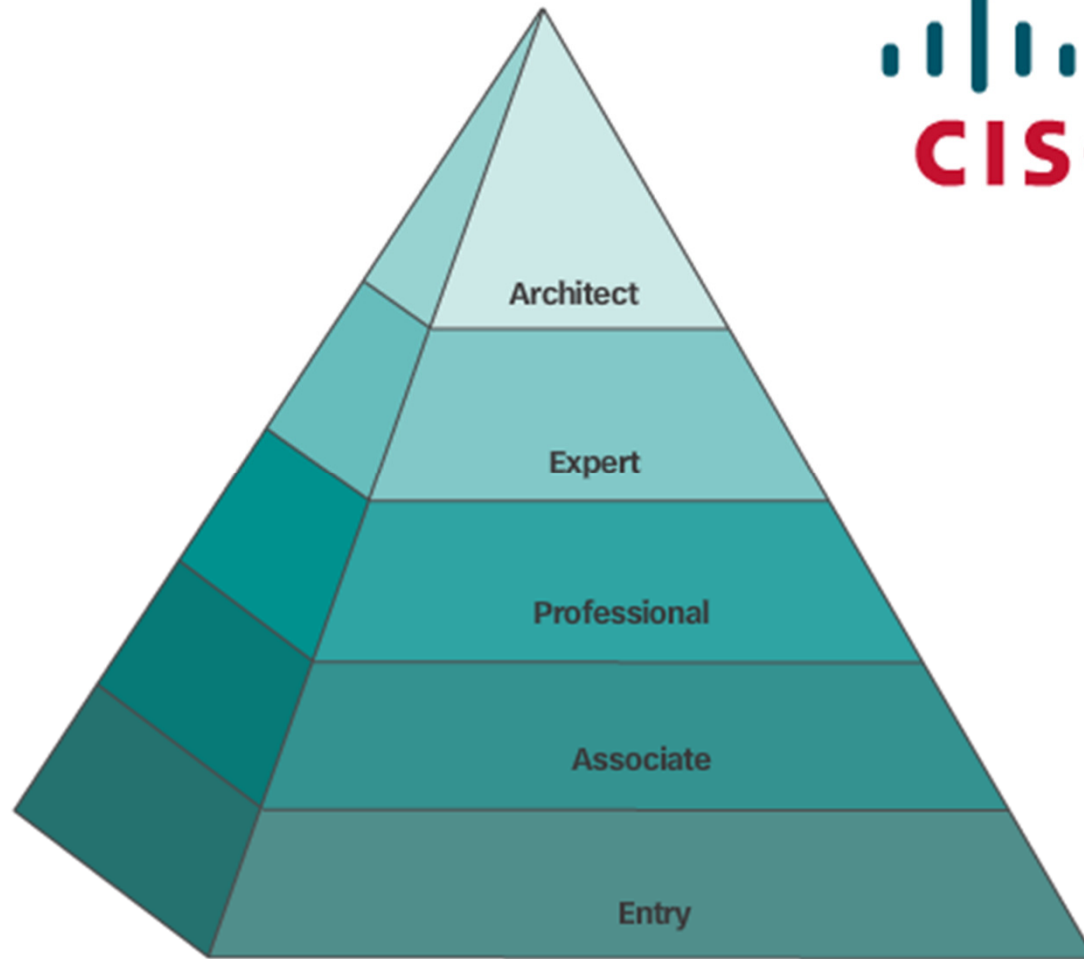

Section 1.5: Summary

Chapter Objectives:

- Explain how multiple networks are used in everyday life.
- Describe the topologies and devices used in a small to medium-sized business network.
- Explain the basic characteristics of a network that supports communication in a small to medium-sized business.
- Explain trends in networking that will affect the use of networks in small to medium-sized businesses.

Thank you.



Cisco Networking Academy
Mind Wide Open